

PNEUMATIC VACUUM GENERATORS AND PUMPSETS

QUANTITY OF AIR SUCKED BY GENERATORS AT DIFFERENT VACUUM LEVELS	PAG. 8.01
VACUUM GENERATOR EVACUATION TIME AT DIFFERENT VACUUM LEVELS	PAG. 8.02
MINIMUM PIPE INTERNAL DIAMETER RECOMMENDED FOR THE GENERATORS	PAG. 8.03
SINGLE-STAGE VACUUM GENERATOR 15 01 10	PAG. 8.04
DIAGRAMS REFERRING TO VACUUM GENERATOR 15 01 10	PAG. 8.05
SINGLE-STAGE VACUUM GENERATOR 15 03 10	PAG. 8.06
DIAGRAMS REFERRING TO VACUUM GENERATOR 15 03 10	PAG. 8.07
SINGLE-STAGE VACUUM GENERATOR WITH EJECTOR 15 02 10	PAG. 8.08
DIAGRAMS REFERRING TO VACUUM GENERATOR 15 02 10	PAG. 8.09
SINGLE-STAGE VACUUM GENERATOR WITH EJECTOR 15 04 10	PAG. 8.10
DIAGRAMS REFERRING TO VACUUM GENERATOR 15 04 10	PAG. 8.11
IN-LINE SINGLE-STAGE VACUUM GENERATOR PVP 1	PAG. 8.12
DIAGRAMS REFERRING TO VACUUM GENERATOR PVP 1	PAG. 8.13
IN-LINE SINGLE-STAGE VACUUM GENERATORS GV 1, GV 2 and GV 3	PAG. 8.14
DIAGRAMS REFERRING TO VACUUM GENERATORS GV 1, GV 2 and GV 3	PAG. 8.15
SINGLE-STAGE VACUUM GENERATOR PVP 2	PAG. 8.16
DIAGRAMS REFERRING TO VACUUM GENERATOR PVP 2	PAG. 8.17
SINGLE-STAGE VACUUM GENERATOR PVP 3	PAG. 8.18
DIAGRAMS REFERRING TO VACUUM GENERATOR PVP 3	PAG. 8.19
SINGLE-STAGE VACUUM GENERATOR PVP 2 M	PAG. 8.20
DIAGRAMS REFERRING TO VACUUM GENERATOR PVP 2 M	PAG. 8.21
SINGLE-STAGE VACUUM GENERATOR PVP 7 X	PAG. 8.22
DIAGRAMS REFERRING TO VACUUM GENERATOR PVP 7 X	PAG. 8.23
SINGLE-STAGE VACUUM GENERATOR PVP 7 SX	PAG. 8.24
DIAGRAMS REFERRING TO VACUUM GENERATORS PVP 7 SX	PAG. 8.25
FIXING SUPPORTS FOR SINGLE-STAGE VACUUM GENERATORS	PAG. 8.26 ÷ 8.27
MULTI-STAGE VACUUM GENERATORS - GENERAL INFORMATION	PAG. 8.28
MULTI-STAGE VACUUM GENERATORS SERIES M	PAG. 8.29
DIAGRAMS REFERRING TO VACUUM GENERATORS M 3 and M 7	PAG. 8.30
MULTI-STAGE VACUUM GENERATORS M 10, M 14 and M 18	PAG. 8.31
DIAGRAMS REFERRING TO VACUUM GENERATORS M 10, M 14 and M 18	PAG. 8.32
MULTI-STAGE VACUUM GENERATORS M 3 SSX and M 7 SSX	PAG. 8.33
DIAGRAMS REFERRING TO VACUUM GENERATORS M 3 SSX and M 7 SSX	PAG. 8.34
MULTI-STAGE VACUUM GENERATORS M 10 SSX, M 14 SSX and M 18 SSX	PAG. 8.35
DIAGRAMS REFERRING TO VACUUM GENERATORS M 10 SSX, M 14 SSX and M 18 SSX	PAG. 8.36
FIXING SUPPORTS FOR MULTI-STAGE VACUUM GENERATORS SERIES M	PAG. 8.37
MULTI-STAGE AND MULTI-FUNCTION VACUUM GENERATORS SERIES MVG – GENERAL INFORMATION	PAG. 8.38
MULTI-STAGE AND MULTI-FUNCTION VACUUM GENERATORS MVG 3 and MVG 7	PAG. 8.39
DIAGRAMS REFERRING TO VACUUM GENERATORS MVG 3 and MVG 7	PAG. 8.40
MULTI-STAGE AND MULTI-FUNCTION VACUUM GENERATORS MVG 10 and MVG 14	PAG. 8.41
DIAGRAMS REFERRING TO VACUUM GENERATORS MVG 10 and MVG 14	PAG. 8.42
ACCESSORIES AND SPARE PARTS FOR VACUUM GENERATORS SERIES MVG	PAG. 8.43 ÷ 8.45
MULTI-STAGE, MULTI-FUNCTION AND MODULAR VACUUM GENERATORS SERIES GVMM – GENERAL INFORMATION	PAG. 8.46
MULTI-STAGE, MULTI-FUNCTION AND MODULAR VACUUM GENERATORS GVMM 3 and GVMM 7	PAG. 8.47
DIAGRAMS REFERRING TO VACUUM GENERATORS GVMM 3 and GVMM 7	PAG. 8.48
MULTI-STAGE, MULTI-FUNCTION AND MODULAR VACUUM GENERATORS GVMM 10 and GVMM 14	PAG. 8.49
DIAGRAMS REFERRING TO VACUUM GENERATORS GVMM 10 and GVMM 14	PAG. 8.50
MULTI-STAGE, MULTI-FUNCTION AND MODULAR INTERMEDIATE VACUUM MODULES SERIES MI – GENERAL INFORMATION	PAG. 8.51
INTERMEDIATE VACUUM MODULES MI 3 and MI 7	PAG. 8.52
DIAGRAMS REFERRING TO INTERMEDIATE VACUUM MODULES MI 3 and MI 7	PAG. 8.53
INTERMEDIATE VACUUM MODULES MI 10 and MI 14	PAG. 8.54
DIAGRAMS REFERRING TO INTERMEDIATE VACUUM MODULES MI 10 and MI 14	PAG. 8.55
ACCESSORIES AND SPARE PARTS FOR VACUUM GENERATORS AND MODULES SERIES GVMM AND MI	PAG. 8.56 ÷ 8.58
MODULAR VACUUM SYSTEMS SET-UP	PAG. 8.59
SINGLE-STAGE AND MULTI-FUNCTION VACUUM GENERATORS SERIES AVG – GENERAL INFORMATION	PAG. 8.60
GENERATORI DI VUOTO MONOSTADIO E MULTIFUNZIONE AVG 18 e AVG 25	PAG. 8.61
DIAGRAMS REFERRING TO VACUUM GENERATORS AVG 18 e AVG 25	PAG. 8.62

PNEUMATIC VACUUM GENERATORS AND PUMPSETS

SINGLE-STAGE AND MULTI-FUNCTION VACUUM GENERATORS WITH SHOCKPROOF PROTECTION	
AVG 18 P e AVG 25 P	PAG. 8.63
VACUUM GENERATORS ACCESSORIES AND SPARE PARTS SERIES AVG	PAG. 8.64 ÷ 8.65
MULTI-STAGE VACUUM GENERATORS PVP 12 MX and PVP 25 MX	PAG. 8.66
DIAGRAMS REFERRING TO VACUUM GENERATORS PVP 12 MX and PVP 25 MX	PAG. 8.67
MULTI-STAGE VACUUM GENERATORS PVP 40 M, PVP 70 M and PVP 100 M	PAG. 8.68
DIAGRAMS REFERRING TO VACUUM GENERATORS PVP 40 M, PVP 70 M and PVP 100 M	PAG. 8.69
MULTI-STAGE VACUUM GENERATORS PVP 140 M, PVP 170 M and PVP 200 M	PAG. 8.70
DIAGRAMS REFERRING TO VACUUM GENERATORS PVP 140 M, PVP 170 M and PVP 200 M	PAG. 8.71
MULTI-STAGE VACUUM GENERATORS PVP 250 M and PVP 300 M	PAG. 8.72
DIAGRAMS REFERRING TO VACUUM GENERATORS PVP 250 M and PVP 300 M	PAG. 8.73
MULTI-STAGE VACUUM GENERATORS PVP 25 MDX, PVP 35 MDX and PVP 50 MDX	PAG. 8.74
DIAGRAMS REFERRING TO VACUUM GENERATORS PVP 25 MDX, PVP 35 MDX and PVP 50MDX	PAG. 8.75
MULTI-STAGE VACUUM GENERATORS PVP 60 MDX and PVP 75 MDX	PAG. 8.76
DIAGRAMS REFERRING TO VACUUM GENERATORS PVP 60 MDX and PVP 75 MDX	PAG. 8.77
VACUUM GENERATORS ACCESSORIES PVP 25 ÷ 75 MDX	PAG. 8.78 ÷ 8.79
SILENCERS	PAG. 8.80
MODULAR MULTI-STAGE VACUUM GENERATORS PVP 150 ÷ 600 MD – GENERAL INFORMATION	PAG. 8.81
MODULAR MULTI-STAGE VACUUM GENERATORS PVP 150 MD and PVP 300 MD	PAG. 8.82
DIAGRAMS REFERRING TO VACUUM GENERATORS PVP 150 MD and PVP 300 MD	PAG. 8.83
MODULAR MULTI-STAGE VACUUM GENERATORS PVP 450 MD and PVP 600 MD	PAG. 8.84
DIAGRAMS REFERRING TO VACUUM GENERATORS PVP 450 MD and PVP 600 MD	PAG. 8.85
ADJUSTABLE VACUUM GENERATORS CONVEYOR PVR 25 and PVR 50	PAG. 8.86
DIAGRAMS REFERRING TO VACUUM GENERATORS CONVEYOR PVR 25 and PVR 50	PAG. 8.87
ADJUSTABLE VACUUM GENERATORS CONVEYOR PVR 100 and PVR 200	PAG. 8.88
DIAGRAMS REFERRING TO VACUUM GENERATORS CONVEYOR PVR 100 and PVR 200	PAG. 8.89
ACCESSORIES FOR ADJUSTABLE VACUUM GENERATORS CONVEYOR	PAG. 8.90
FLOW GENERATORS VACUUM JET CX 7 and CX 10	PAG. 8.91
DIAGRAMS REFERRING TO FLOW GENERATORS CX 7 and CX 10	PAG. 8.92
FLOW GENERATORS VACUUM JET CX 13 and CX 19	PAG. 8.93
DIAGRAMS REFERRING TO FLOW GENERATORS CX 13 and CX 19	PAG. 8.94
FLOW GENERATORS VACUUM JET CX 25, CX 38 and CX 50	PAG. 8.95
DIAGRAMS REFERRING TO FLOW GENERATORS CX 25, CX 38 and CX50	PAG. 8.96
MINI PNEUMATIC PUMPSETS DOP 06 and DOP 10	PAG. 8.97
MINI PNEUMATIC PUMPSETS DOP 20	PAG. 8.98
PNEUMATIC PUMPSETS DOP 25	PAG. 8.99
PNEUMATIC PUMPSETS DOP 50	PAG. 8.100
PNEUMATIC PUMPSETS DOP 100	PAG. 8.101
PNEUMATIC PUMPSETS DOP 150	PAG. 8.102
PNEUMATIC PUMPSETS DOP 300	PAG. 8.103
PNEUMATIC MINI PUMPSET AND PUMPSET COMPONENTS:	
MINI PNEUMATIC PUMPSET TANKS	PAG. 8.104
TANKS FOR PNEUMATIC PUMPSET DOP 25, 50 e 100	PAG. 8.105
TANKS FOR PNEUMATIC PUMPSET DOP 150 e 300	PAG. 8.106
PNEUMATIC CONTROL GEAR FOR MINI PUMPSETS AND PUMPSETS	PAG. 8.107 ÷ 8.108



**TABLE REGARDING THE QUANTITY OF AIR SUCKED BY GENERATORS
AT DIFFERENT VACUUM LEVELS**

Art Generator	Supply press. bar (g)	Air consumption NI/s	Quantity of sucked air (NI/s) at different vacuum levels (-KPa)									Max. vacuum level -KPa
			0	10	20	30	40	50	60	70	80	
15 01 10	6	0.9	0.77	0.66	0.61	0.55	0.44	0.29	0.19	0.09	--	83
15 02 10	6	0.9	0.77	0.66	0.61	0.55	0.44	0.29	0.19	0.09	--	83
15 03 10	6	1.8	1.39	1.30	1.15	1.00	0.89	0.77	0.69	0.44	0.04	85
15 04 10	6	1.8	1.39	1.30	1.15	1.00	0.89	0.77	0.69	0.44	0.04	85
PVP 1	5	0.8	0.27	0.25	0.22	0.18	0.12	0.07	0.06	0.03	0.004	85
PVP 2	6	1.0	0.83	0.70	0.65	0.52	0.37	0.23	0.13	0.07	0.007	85
PVP 2 M	6	1.0	0.83	0.70	0.65	0.52	0.37	0.23	0.13	0.07	0.007	85
PVP 3	6	1.5	1.03	0.82	0.72	0.61	0.41	0.24	0.15	0.08	0.008	85
PVP 7 X	6	3.2	2.47	2.28	2.10	1.94	1.44	0.97	0.86	0.54	0.05	85
PVP 7 SX	6	3.2	2.47	2.28	2.10	1.94	1.44	0.97	0.86	0.54	0.05	85
GV 1	5	0.7	0.27	0.23	0.20	0.17	0.13	0.06	0.05	0.03	0.004	85
GV 2	5	0.7	0.27	0.23	0.20	0.17	0.13	0.06	0.05	0.03	0.004	85
GV 3	5	0.7	0.27	0.23	0.20	0.17	0.13	0.06	0.05	0.03	0.004	85
M 3 - M 3 SSX	5	0.8	1.00	0.83	0.61	0.34	0.18	0.12	0.10	0.07	0.03	85
M 7 - M 7 SSX	5	1.4	1.72	1.28	0.89	0.50	0.37	0.27	0.16	0.11	0.05	85
M 10 - M 10 SSX	5	1.9	2.61	2.00	1.55	0.80	0.64	0.50	0.29	0.19	0.09	85
M 14 - M 14 SSX	5	2.5	3.50	2.33	1.72	1.00	0.89	0.67	0.35	0.24	0.11	85
M 18 - M 18 SSX	5	3.6	5.00	3.50	2.78	2.02	1.02	0.75	0.44	0.30	0.14	85
MVG 3	5	0.8	0.89	0.69	0.41	0.23	0.18	0.12	0.10	0.07	0.03	85
MVG 7	5	1.3	1.83	1.44	1.11	0.63	0.41	0.25	0.16	0.11	0.05	85
MVG10	5	1.7	2.55	1.85	1.30	0.75	0.64	0.48	0.30	0.20	0.09	85
MVG14	5	2.1	3.40	2.45	1.84	1.05	0.88	0.61	0.36	0.24	0.11	85
GVMM 3	5	0.8	0.83	0.66	0.38	0.20	0.16	0.11	0.09	0.06	0.02	85
GVMM 7	5	1.3	1.78	1.30	0.98	0.56	0.44	0.29	0.20	0.14	0.06	85
GVMM 10	5	1.7	2.52	2.00	1.66	0.97	0.56	0.40	0.22	0.16	0.07	85
GVMM 14	5	2.1	3.35	2.42	1.84	0.99	0.80	0.58	0.34	0.22	0.10	85
MI 3	5	0.8	0.83	0.66	0.38	0.20	0.16	0.11	0.09	0.06	0.02	85
MI 7	5	1.3	1.78	1.30	0.98	0.56	0.44	0.29	0.20	0.14	0.06	85
MI 10	5	1.7	2.52	2.00	1.66	0.97	0.56	0.40	0.22	0.16	0.07	85
MI 14	5	2.1	3.35	2.42	1.84	0.99	0.80	0.58	0.34	0.22	0.10	85
AVG 18	6	6.4	4.83	4.58	4.04	3.58	2.72	1.90	1.68	1.07	0.10	85
AVG 25	6	9.6	7.00	6.63	5.86	5.18	3.94	2.76	2.44	1.54	0.15	85
PVP 12 MX	6	1.8	5.80	4.14	2.76	1.38	0.98	0.78	0.59	0.41	0.23	90
PVP 25 MX	6	3.2	8.61	6.15	4.10	2.05	1.46	1.17	0.88	0.61	0.35	90
PVP 40 M	6	3.2	11.66	8.32	5.55	2.77	1.98	1.58	1.19	0.83	0.47	90
PVP 70 M	6	6.6	22.22	15.87	10.58	5.29	3.77	3.02	2.27	1.58	0.90	90
PVP 100 M	6	9.8	30.00	21.42	14.28	7.14	5.10	4.08	3.06	2.14	1.22	90
PVP 140 M	6	13.0	42.22	30.15	20.10	10.05	7.18	5.74	4.31	3.02	1.72	90
PVP 170 M	6	16.3	50.55	36.10	24.07	12.03	8.59	6.87	5.17	3.61	2.06	90
PVP 200 M	6	19.4	55.55	39.67	26.45	13.22	9.44	7.55	5.68	3.97	2.27	90
PVP 250 M	6	24.0	77.77	55.55	37.03	18.51	13.22	10.58	7.95	5.56	3.17	90
PVP 300 M	6	29.0	88.88	63.48	42.32	21.16	15.11	12.09	9.09	6.35	3.63	90
PVP 25 MDX	6	3.2	11.94	8.53	5.68	2.84	2.03	1.62	1.22	0.85	0.48	90
PVP 35 MDX	6	4.8	15.83	11.30	7.53	3.76	2.69	2.15	1.61	1.13	0.64	90
PVP 50 MDX	6	6.5	18.88	13.48	8.99	4.49	3.21	2.56	1.93	1.35	0.77	90
PVP 60 MDX	6	8.2	25.55	18.25	12.16	6.08	4.34	3.47	2.61	1.82	1.04	90
PVP 75 MDX	6	9.8	28.61	20.43	13.62	6.81	4.86	3.89	2.92	2.04	1.16	90
PVP 150 MD	6	16.0	55.55	39.68	26.45	13.22	9.44	7.55	5.68	3.97	2.27	90
PVP 300 MD	6	32.0	111.11	79.36	52.91	26.45	18.89	15.11	11.36	7.94	4.54	90
PVP 450 MD	6	47.8	161.11	115.07	76.71	38.35	27.39	21.91	16.48	11.52	6.58	90
PVP 600 MD	6	63.2	208.33	148.80	99.20	49.60	35.43	28.34	21.31	14.90	8.51	90

TABLE REGARDING VACUUM GENERATOR EVACUATION TIME, AT DIFFERENT VACUUM LEVELS

Art. Generator	Supply press. bar (g)	Max. vacuum level -KPa	Evacuation time (ms/l= s/m ³) at different vacuum levels (-KPa)									
			10	20	30	40	50	60	70	80	85	90
15 01 10	6	82	139	278	472	727	1171	1628	2720	4928	--	
15 02 10	6	82	139	278	472	727	1171	1628	2720	4928	--	
15 03 10	6	85	77	154	261	403	649	902	1506	2730	3876	
15 04 10	6	85	77	154	261	403	649	902	1506	2730	3876	
PVP 1	5	85	393	786	1336	2057	3312	4605	7690	13935	19787	
PVP 2	6	85	128	257	438	675	1087	1511	2523	4572	6492	
PVP 2 M	6	85	128	257	438	675	1087	1511	2523	4572	6492	
PVP 3	6	85	104	207	353	544	875	1217	2033	3684	5232	
PVP 7 X	6	85	43	86	147	226	365	507	847	1536	2181	
PVP 7 SX	6	85	43	86	147	226	365	507	847	1536	2181	
GV 1	5	85	394	788	1339	2063	3322	4617	7711	13973	19841	
GV 2	5	85	394	788	1339	2063	3322	4617	7711	13973	19841	
GV 3	5	85	394	788	1339	2063	3322	4617	7711	13973	19841	
M 3 - M 3 SSX	5	85	106	244	491	969	1642	2398	4004	7128	10122	
M 7 - M 7 SSX	5	85	61	142	285	563	954	1394	2328	4144	5885	
M 10 - M 10 SSX	5	85	40	93	188	371	629	918	1534	2731	3878	
M 14 - M 14 SSX	5	85	30	69	140	276	469	685	1144	2036	2892	
M 18 - M 18 SSX	5	85	21	48	98	193	327	478	799	1423	2020	
MVG 3	5	85	119	274	552	1088	1845	2694	4499	8009	11373	
MVG 7	5	85	58	133	268	529	897	1310	2188	3895	5531	
MVG 10	5	85	41	95	192	379	642	938	1567	2790	3962	
MVG 14	5	85	31	71	144	284	482	704	1175	2092	2971	
GVMM 3	5	85	128	294	592	1167	1978	2889	4824	8588	12195	
GVMM 7	5	85	59	137	275	543	921	1344	2245	3997	5676	
GVMM 10	5	85	42	97	195	384	651	951	1589	2828	4016	
GVMM 14	5	85	31	72	146	288	489	714	1193	2124	3016	
MI 3	5	85	128	294	592	1167	1978	2889	4824	8588	12195	
MI 7	5	85	59	137	275	543	921	1344	2245	3997	5676	
MI 10	5	85	42	97	195	384	651	951	1589	2828	4016	
MI 14	5	85	31	72	146	288	489	714	1193	2124	3016	
AVG 18	6	85	22	44	75	115	185	258	430	798	1107	
AVG 25	6	85	15	30	52	80	128	178	297	538	764	
PVP 12 MX	6	90	15.4	38.7	85.1	204.4	365.9	559.8	929.4	1607.8	--	5916
PVP 25 MX	6	90	10.4	26.0	57.3	137.7	246.5	377.1	626.0	1083.1	--	3986
PVP 40 M	6	90	7.7	19.2	42.3	101.6	182.0	278.4	462.3	799.8	--	2943
PVP 70 M	6	90	4.0	10.1	22.2	53.3	95.5	146.1	242.6	419.7	--	1544
PVP 100 M	6	90	3.0	7.4	16.4	39.5	70.7	108.2	179.6	310.8	--	1144
PVP 140 M	6	90	2.1	5.3	11.7	28.0	50.2	76.9	127.6	220.8	--	812
PVP 170 M	6	90	1.7	4.4	9.7	23.4	42.0	64.2	106.6	184.5	--	678
PVP 200 M	6	90	1.6	4.0	8.9	21.3	38.2	58.4	97.0	167.8	--	618
PVP 250 M	6	90	1.1	2.9	6.4	15.2	27.3	41.8	69.3	119.9	--	442
PVP 300 M	6	90	1.0	2.5	5.5	13.3	23.8	36.5	60.6	104.9	--	386
PVP 25 MDX	6	90	7.5	18.8	41.3	99.3	177.7	271.9	451.4	781.0	--	2874
PVP 35 MDX	6	90	5.6	14.1	31.2	74.9	134.0	205.1	340.5	589.1	--	2168
PVP 50 MDX	6	90	4.7	11.9	26.2	62.8	112.4	172.0	285.5	494.0	--	1818
PVP 60 MDX	6	90	3.5	8.8	19.3	46.4	83.0	127.0	211.0	365.0	--	1343
PVP 75 MDX	6	90	3.1	7.8	17.2	41.4	74.2	113.5	188.4	326.0	--	1200
PVP 150 MD	6	90	1.6	4.0	8.9	21.3	38.2	58.4	97.0	167.8	--	618
PVP 300 MD	6	90	0.8	2.0	4.4	10.6	19.1	29.2	48.5	83.9	--	309
PVP 450 MD	6	90	0.5	1.4	3.0	7.4	13.2	20.1	33.5	57.9	--	213
PVP 600 MD	6	90	0.4	1.0	2.4	5.7	10.2	15.6	25.9	44.8	--	16

MINIMUM PIPE INTERNAL DIAMETER RECOMMENDED FOR THE GENERATORS

Choosing the right fittings and pipe sections is essential for the correct operation of the vacuum plant. To obtain the highest performance by the vacuum generators, please see the temperature below and keep to the data shown in it.

Vacuum generator Art.	Compressed air Pipe internal Ø mm	Vacuum Pipe internal Ø mm	Exhaust Pipe internal Ø mm
15 01 10	2	6	8
15 02 10	2	6	8
15 03 10	2	8	10
15 04 10	2	8	10
PVP 1	2	4	=
PVP 2	2	6	8
PVP 2 M	2	6	8
PVP 3	2	6	8
PVP 7 X	4	10	=
PVP 7 SX	4	10	=
GV 1	2	4	6
GV 2	2	4	6
GV 3	2	4	6
M 3 - M 3 SSX	2	6	=
M 7 - M 7 SSX	2	8	=
M 10 - M 10 SSX	4	10	=
M 14 - M 14 SSX	4	12	=
M 18 - M 18 SSX	4	15	=
MVG 3	2	6	=
MVG 7	2	8	=
MVG 10	4	10	=
MVG 14	4	12	=
GVMM 3	2	6	=
GVMM 7	2	8	=
GVMM 10	4	10	=
GVMM 14	4	12	=
MI 3	2	6	=
MI 7	2	8	=
MI 10	4	10	=
MI 14	4	12	=
AVG 18	8	15	=
AVG 25	9	15	=
PVP 12 MX	4	12	14
PVP 25 MX	4	15	6 x 4 pipes
PVP 40 M PA 40 - PS 40	6	27	=
PVP 70 M PA 70 - PS 70	8	27	=
PVP 100 M PA 100 - PS 100	9	27	=
PVP 140 M PA 140 - PS 140	9	35	=
PVP 170 M PA 170 - PS 170	12	35	=
PVP 200 M PA 200 - PS 200	12	40	=
PVP 250 M PA 250 - PS 250	12	40	=
PVP 300 M PA 300 - PS 300	12	50	=
PVP 25 MDX	6	27	=
PVP 35 MDX	6	27	=
PVP 50 MDX	6	27	=
PVP 60 MDX	8	27	=
PVP 75 MDX	8	27	=
PVP 150 MD	12	35	=
PVP 300 MD	12	40	=
PVP 450 MD	16	50	=
PVP 600 MD	18	60	=

Note: Data valid for pipes max. 2 m long.

SINGLE-STAGE VACUUM GENERATORS 15 01 10 and 15 03 10

Single-stage vacuum generator operation is based on the Venturi principle.

Supplying the generator with compressed air in P, vacuum will be generated at connection U, while both the supply and the sucked air will be released through R.

By interrupting the air supply in P, the vacuum effect in U will also stop.

Vacuum generators 15 01 10 and 15 03 10 are generally used for controlling vacuum cups, for gripping and handling non-porous objects and equipment with low capacity requirements.

They are fully made with anodised aluminium.

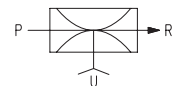
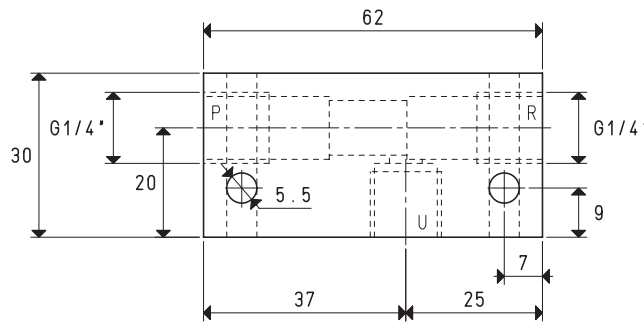
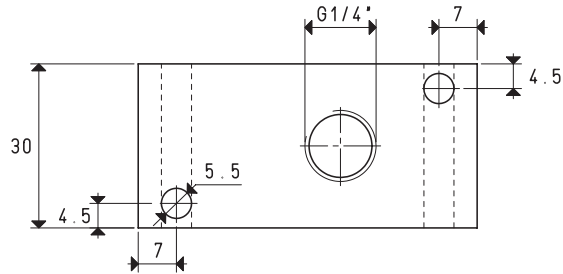

P=COMPRESSED AIR CONNECTION

R=EXHAUST

U=VACUUM CONNECTION

Art.	15 01 10		
Quantity of sucked air	cum/h	2.7	2.8
Max. vacuum level	-kPa	55	70
Final pressure	mbar abs.	450	300
Supply pressure	bar (g)	4	5
Air consumption	l/s	0.7	0.8
Working temperature	°C		-20 / +80
Noise level	dB(A)		63
Weight	g		140

Note: All the vacuum data indicated in the table are valid at the normal atmospheric pressure of 1013 mbar and are obtained with a constant supply pressure.

Air capacity (NI/s) at different vacuum levels (-Kpa)

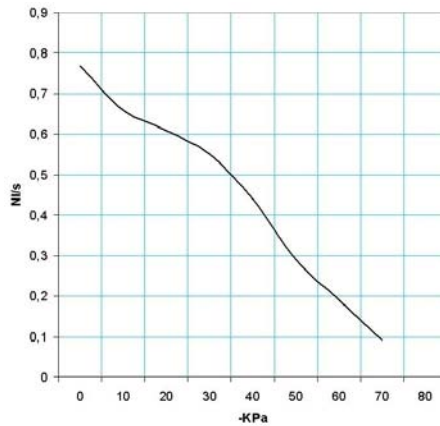

Generator art.	Supply press. bar (g)	Air consumption NI/s	Air capacity (NI/s) at different vacuum levels (-KPa)										Max. vacuum level -KPa
			0	10	20	30	40	50	60	70	80		
15 01 10	6.0	0.9	0.77	0.66	0.61	0.55	0.44	0.29	0.19	0.09	--	83	

Evacuation time (ms/l=s/m³) at different vacuum levels (-Kpa)

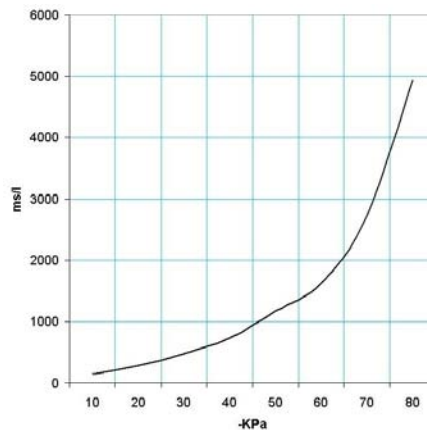

Generator art.	Supply press. bar (g)	Air consumption NI/s	Evacuation time (ms/l = s/m³) at different vacuum levels (-KPa)								Max. vacuum level -KPa
			10	20	30	40	50	60	70	80	
15 01 10	6.0	0.9	139	278	472	727	1171	1628	2720	4928	83

Accessories upon request

Silencer art. SSX 1/4"

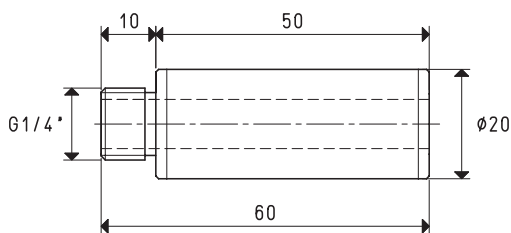

3D drawings available at www.vuototecnica.net

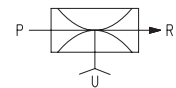
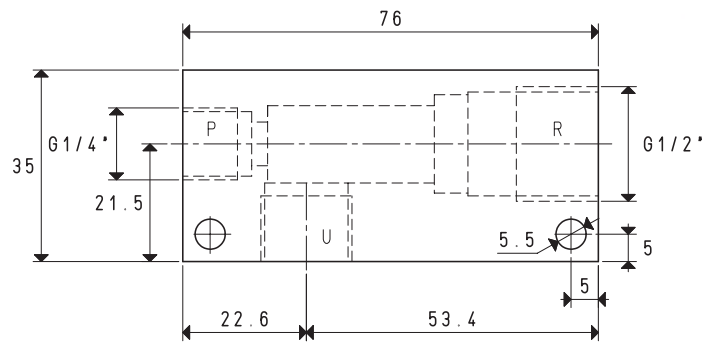
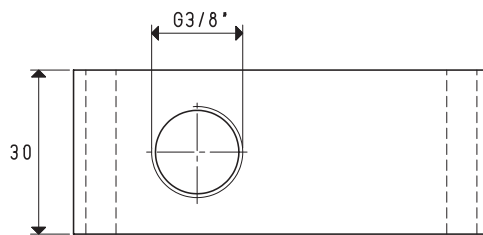

P=COMPRESSED AIR CONNECTION

R=EXHAUST

U=VACUUM CONNECTION

Art.	15 03 10			
Quantity of sucked air	cum/h	4.8	5	6
Max. vacuum level	-kPa	62	78	85
Final pressure	mbar abs.	380	220	150
Supply pressure	bar (g)	4	5	6
Air consumption	l/s	1.3	1.6	1.8
Working temperature	°C	-20 / +80		
Noise level	dB(A)	79		
Weight	g	179		

Note: All the vacuum data indicated in the table are valid at the normal atmospheric pressure of 1013 mbar and are obtained with a constant supply pressure.

Air capacity (NI/s) at different vacuum levels (-KPa)

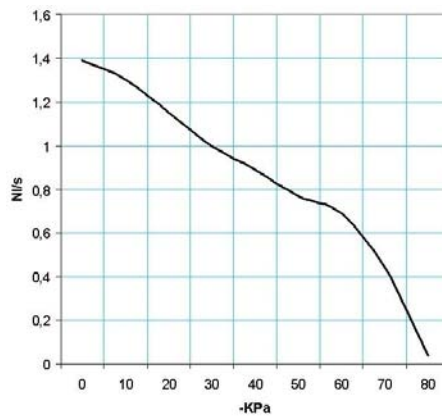

Generator art.	Supply press. bar (g)	Air consumption NI/s	Air capacity (NI/s) at different vacuum levels (-KPa)										Max. vacuum level -KPa
			0	10	20	30	40	50	60	70	80	85	
15 03 10	6.0	1.8	1.39	1.30	1.15	1.00	0.89	0.77	0.69	0.44	0.04	85	

Evacuation time (ms/l=s/m³) at different vacuum levels (-KPa)

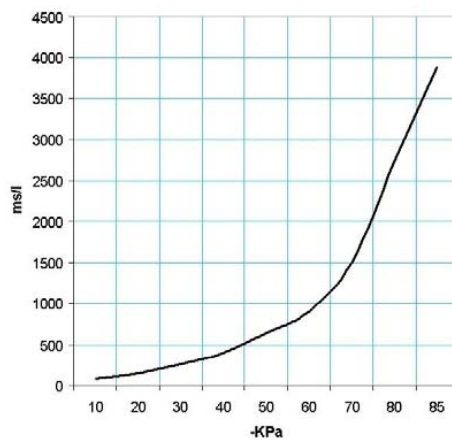

Generator art.	Supply press. bar (g)	Air consumption NI/s	Evacuation time (ms/l = s/m ³) at different vacuum levels (-KPa)										Max. vacuum level -KPa
			10	20	30	40	50	60	70	80	85		
15 03 10	6.0	1.8	77	154	261	403	649	902	1506	2730	3876	85	

Accessories upon req

Silencer art. SSX 1/2"

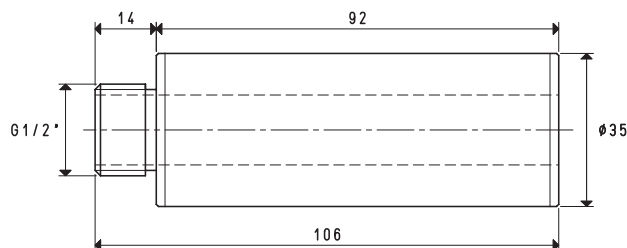

3D drawings available at www.vuototecnica.net

SINGLE-STAGE VACUUM GENERATORS WITH EJECTOR 15 02 10 and 15 04 10

The operation of these single-stage vacuum generators is based on the Venturi principle. Supplying the generator with compressed air in P, vacuum will be generated at connection U, while both the supply and the sucked air will be released through R. At the same time, the chamber contained in the generator is also supplied and, as soon as the supply in P is interrupted, it discharges the compressed air that had been collected in it through connection U, thus rapidly restoring the atmospheric pressure at the service.

If, for example, a vacuum cup is connected to the service U, thanks to this system it will disconnect much rapidly than with the vacuum generators described previously. They are fully made with anodised aluminium.

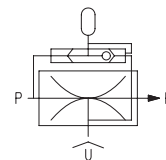
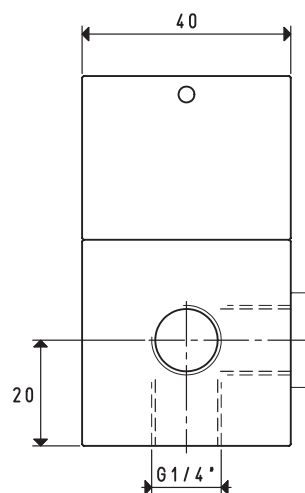
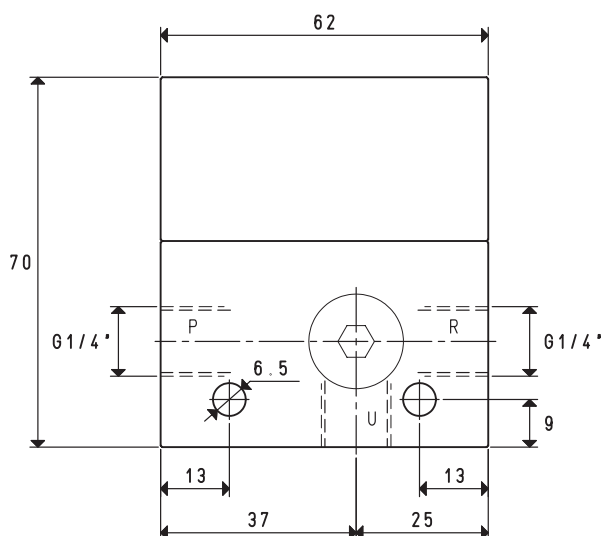

P=COMPRESSED AIR CONNECTION

R=EXHAUST

U=VACUUM CONNECTION

Art.	15 02 10			
Quantity of sucked air	cum/h	2.7	2.8	2.8
Max. vacuum level	-kPa	55	70	83
Final pressure	mbar abs.	450	300	170
Supply pressure	bar (g)	4	5	6
Air consumption	NI/s	0.7	0.8	0.9
Working temperature	°C			-20 / +80
Noise level	dB(A)			63
Weight	g			319
Spare parts				
Sealing kit	art.			00 15 500

Note: All the vacuum data indicated in the table are valid at the normal atmospheric pressure of 1013 mbar and are obtained with a constant supply pressure.

Air capacity (NI/s) at different vacuum levels (-Kpa)

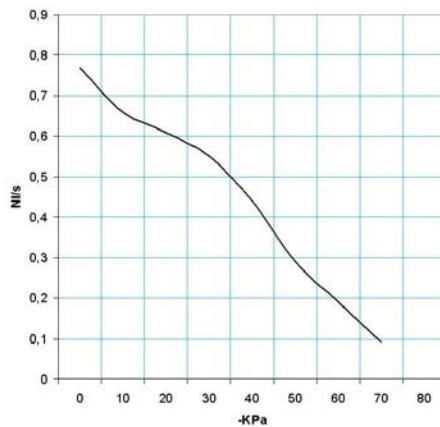

Generator art.	Supply press. bar (g)	Air consumption NI/s	Air capacity (NI/s) at different vacuum levels (-KPa)										Max. vacuum level -KPa
			0	10	20	30	40	50	60	70	80		
15 02 10	6.0	0.9	0.77	0.66	0.61	0.55	0.44	0.29	0.19	0.09	--	83	

Evacuation time (ms/l=s/m³) at different vacuum levels (-Kpa)

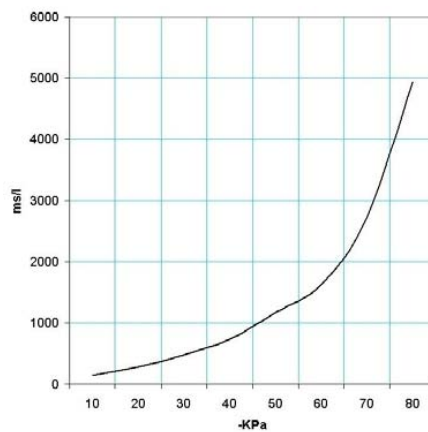

Generator art.	Supply press. bar (g)	Air consumption NI/s	Evacuation time (ms/l = s/m ³) at different vacuum levels (-KPa)								Max. vacuum level -KPa
			10	20	30	40	50	60	70	80	
15 02 10	6.0	0.9	139	278	472	727	1171	1628	2720	4928	83

Accessories upon req

Silencer art. SSX 1/4"

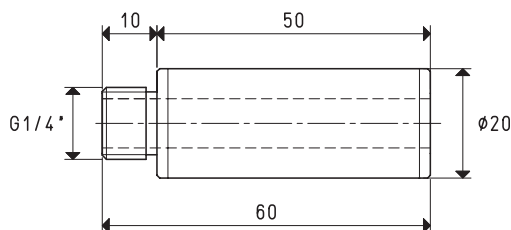

3D drawings available at www.vuototecnica.net

SINGLE-STAGE VACUUM GENERATORS WITH EJECTOR 15 04 10

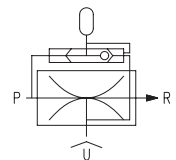
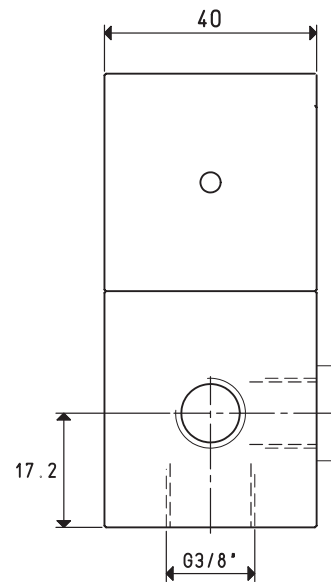
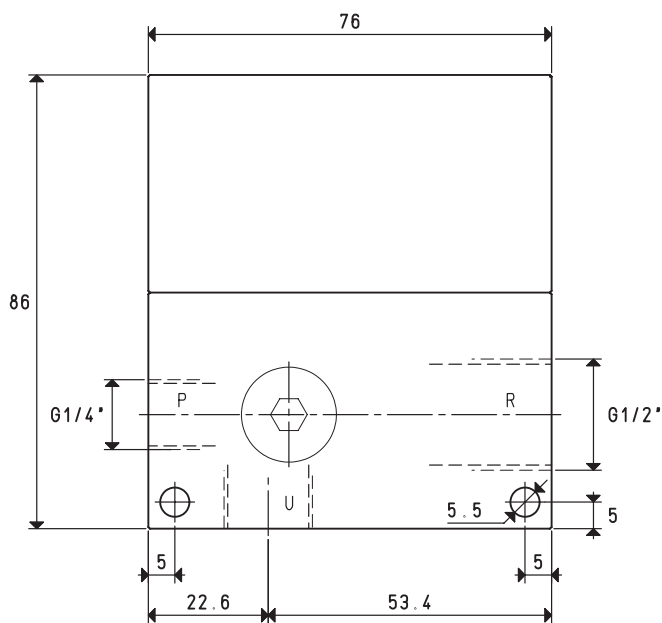

P=COMPRESSED AIR CONNECTION

R=EXHAUST

U=VACUUM CONNECTION

Art.	15 04 10			
Quantity of sucked air	cum/h	4.8	5	5
Max. vacuum level	-kPa	62	78	85
Final pressure	mbar abs.	380	220	150
Supply pressure	bar (g)	4	5	6
Air consumption	l/s	1.3	1.6	1.8
Working temperature	°C			-20 / +80
Noise level	dB(A)			79
Weight	g			501
Spare parts				
Sealing kit	art.			00 15 501

Note: All the vacuum data indicated in the table are valid at the normal atmospheric pressure of 1013 mbar and are obtained with a constant supply pressure.

3D drawings available at www.vuototecnica.net

Air capacity (NI/s) at different vacuum levels (-Kpa)

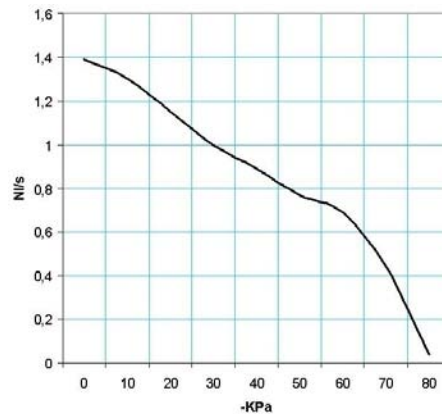

Generator art.	Supply press. bar (g)	Air consumption NI/s	Air capacity (NI/s) at different vacuum levels (-KPa)										Max. vacuum level -KPa
			0	10	20	30	40	50	60	70	80	85	
15 04 10	6.0	1.8	1.39	1.30	1.15	1.00	0.89	0.77	0.69	0.44	0.04	85	

Evacuation time (ms/l=s/m³) at different vacuum levels (-Kpa)

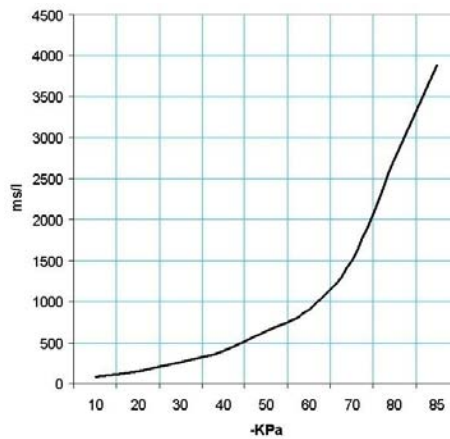

Generator art.	Supply press. bar (g)	Air consumption NI/s	Evacuation time (ms/l = s/m³) at different vacuum levels (-KPa)										Max. vacuum level -KPa
			10	20	30	40	50	60	70	80	85		
15 04 10	6.0	1.8	77	154	261	403	649	902	1506	2730	3876	85	

Accessories upon request

Silencer art. SSX 1/2"

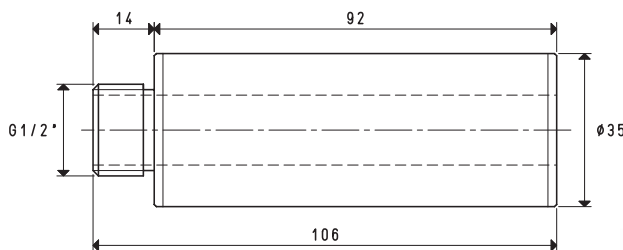

3D drawings available at www.vuototecnica.net

IN-LINE SINGLE-STAGE VACUUM GENERATORS PVP 1

This new range of vacuum generators also exploits the Venturi principle. Their distinctive feature compared with traditional vacuum generators are the two air and vacuum supply connections located in-line, while the exhaust connection of the sucked and exhaust air is orthogonal to them and it is located on the on the generator circumference.

These vacuum generators are easy to disassemble, thus allowing visibility and access to all the components. The advantages of these generators include reduced overall dimensions, easy maintenance and easy assembly to the vacuum cup supports or to the vacuum cup holders. As a standard, they are equipped with pressed stainless steel suction filtre and a special microfibre silencer, which is wrapped around the exhaust connection, making them particularly silent. They are fully made with anodised aluminium.

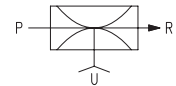
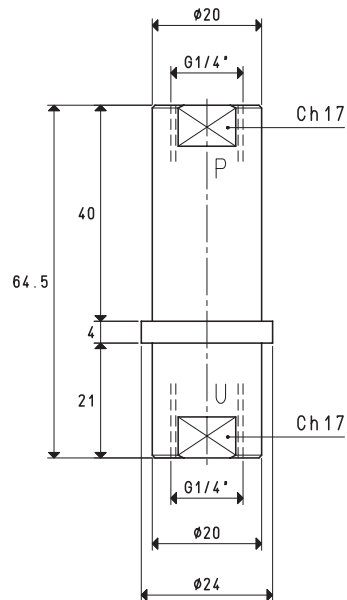

P=COMPRESSED AIR CONNECTION

R=EXHAUST

U=VACUUM CONNECTION

Art.	PVP 1			
Quantity of sucked air	cum/h	0.9	1.0	1.0
Max. vacuum level	-KPa	60	80	85
Final pressure	mbar abs.	400	200	150
Supply pressure	bar (g)	3	4	5
Air consumption	NI/s	0.5	0.6	0.8
Working temperature	°C	-20 / +80		
Noise level	dB(A)	62		
Weight	g	44		
Spare parts				
Silencer	art.			00 15 114
Suction filtre	art.			SP 1/4 I

Note: All the vacuum data indicated in the table are valid at the normal atmospheric pressure of 1013 mbar and are obtained with a constant supply pressure.

Air capacity (NI/s) at different vacuum levels (-Kpa)

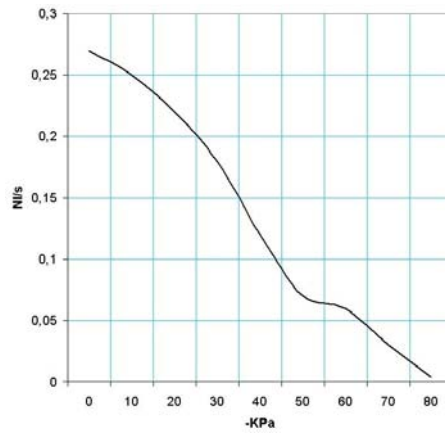

Generator art.	Supply press. bar (g)	Air consumption NI/s	Air capacity (NI/s) at different vacuum levels (-KPa)										Max. vacuum level -KPa
			0	10	20	30	40	50	60	70	80		
PVP 1	5.0	0.8	0.27	0.25	0.22	0.18	0.12	0.07	0.06	0.03	0.004	85	

Evacuation time (ms/l=s/m³) at different vacuum levels (-Kpa)

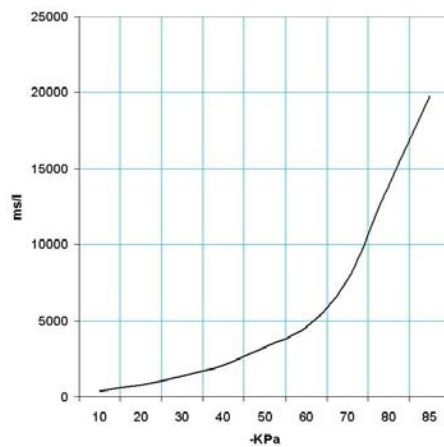

Generator art.	Supply press. bar (g)	Air consumption NI/s	Evacuation time (ms/l = s/m ³) at different vacuum levels (-KPa)										Max. vacuum level -KPa
			10	20	30	40	50	60	70	80	85		
PVP 1	5.0	0.8	393	786	1336	2057	3312	4605	7690	13935	19787	85	

IN-LINE SINGLE-STAGE VACUUM GENERATORS GV 1, GV 2 and GV 3

The operation of these vacuum generators is also based on the Venturi principle.

Their distinctive feature compared with traditional vacuum generators are the two air and vacuum supply connections located in-line, while the exhaust connection of the sucked and exhaust air is orthogonal to them.

The advantages of these generators include reduced overall dimensions, easy maintenance and easy assembly. These vacuum generators can be assembled directly onto the vacuum cup supports or vacuum cup holders. They are fully made with anodised aluminium, except for the exhaust nozzle which is made with brass.

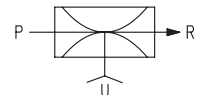
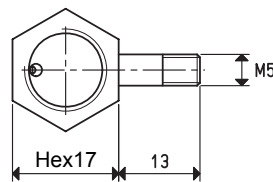
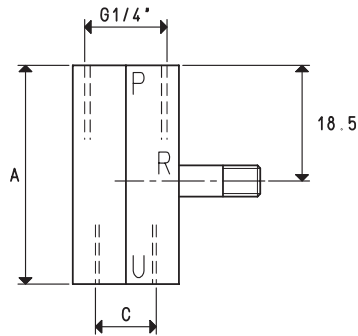

3D drawings available at www.vuototecnica.net

P=COMPRESSED AIR CONNECTION		R=EXHAUST		U=VACUUM CONNECTION					
Art.				GV1		GV2		GV3	
Quantity of sucked air	cum/h	1.0	1.0	1.0	1.0	1.0	1.0	1.0	1.0
Max. vacuum level	-KPa	60	75	85	60	75	85	60	75
Final pressure	mbar abs.	400	250	150	400	250	150	400	250
Supply pressure	bar (g)	3	4	5	3	4	5	3	4
Air consumption	NI/s	0.5	0.6	0.7	0.5	0.6	0.7	0.5	0.6
Working temperature	°C			-20 / +80		-20 / +80		-20 / +80	
Noise level	dB(A)			70		70		70	
Weight	g			19		20		21	
A				30		35		38	
C	∅			M5		G1/8"		G1/4"	

Note: All the vacuum data indicated in the table are valid at the normal atmospheric pressure of 1013 mbar and are obtained with a constant supply pressure.

Air capacity (NI/s) at different vacuum levels (-Kpa)

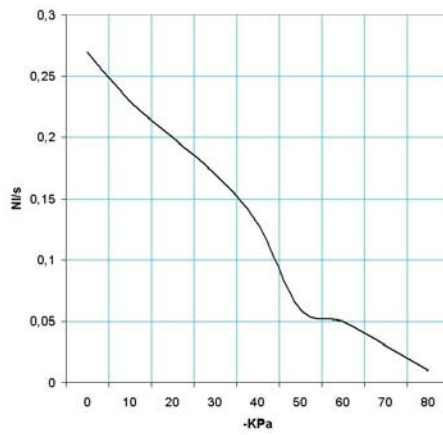

Generator art.	Supply press. bar (g)	Air consumption NI/s	Air capacity (NI/s) at different vacuum levels (-KPa)										Max. vacuum level -KPa
			0	10	20	30	40	50	60	70	80		
GV1 - GV2 - GV3	5.0	0.7	0.27	0.23	0.20	0.17	0.13	0.06	0.05	0.03	0.004	85	

Evacuation time (ms/l=s/m³) at different vacuum levels (-Kpa)

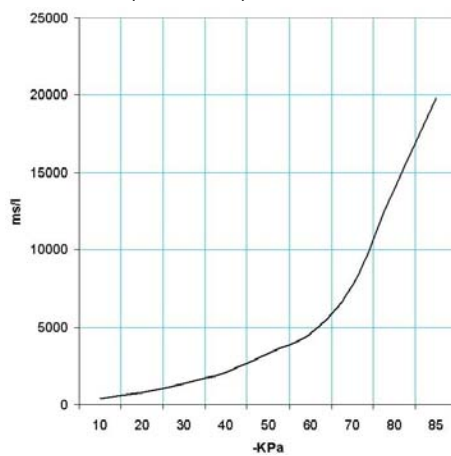

Generator art.	Supply press. bar (g)	Air consumption NI/s	Evacuation time (ms/l = s/m ³) at different vacuum levels (-KPa)										Max. vacuum level -KPa
			10	20	30	40	50	60	70	80	85		
GV1 - GV2 - GV3	5.0	0.7	394	788	1339	2063	3322	4617	7711	13973	19841	85	

SINGLE-STAGE VACUUM GENERATORS PVP 2 and PVP 3

With their extremely reduced size and high performance, these single-stage vacuum generators operate exploiting the Venturi principle.

Supplying the generator with compressed air in P, vacuum will be generated at connection U, while both the supply and the sucked air will be released through R.

By interrupting the air supply in P, the vacuum effect in U will also stop.

The vacuum generators described in this page are generally used for interconnecting vacuum cups, for gripping and handling non-porous objects and equipment with low capacity requirements.

They are made with anodised aluminium with brass ejectors.

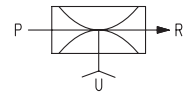
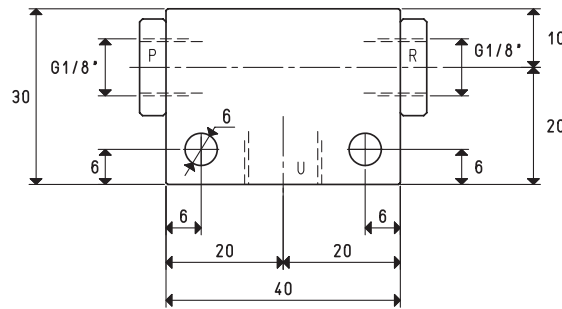
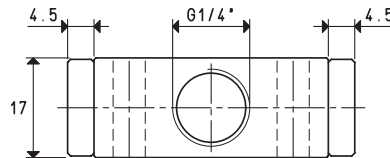

P=COMPRESSED AIR CONNECTION

R=EXHAUST

U=VACUUM CONNECTION

Art.	PVP 2		
Quantity of sucked air	cum/h	2.8	3.0
Max. vacuum level	-kPa	60	85
Final pressure	mbar abs.	400	150
Supply pressure	bar (g)	4	6
Air consumption	l/s	0.7	1.0
Working temperature	°C		-20 / +80
Noise level	dB(A)		78
Weight	g		70

Note: All the vacuum data indicated in the table are valid at the normal atmospheric pressure of 1013 mbar and are obtained with a constant supply pressure.

Air capacity (NI/s) at different vacuum levels (-Kpa)

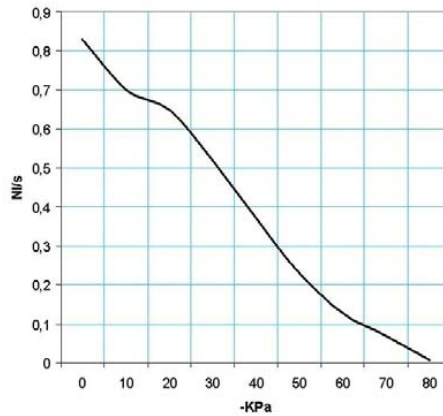

Generator art.	Supply press. bar (g)	Air consumption NI/s	Air capacity (NI/s) at different vacuum levels (-KPa)										Max. vacuum level -KPa
			0	10	20	30	40	50	60	70	80	85	
PVP 2	6.0	1.0	0.83	0.70	0.65	0.52	0.37	0.23	0.13	0.07	0.007	85	

Evacuation time (ms/l=s/m³) at different vacuum levels (-Kpa)

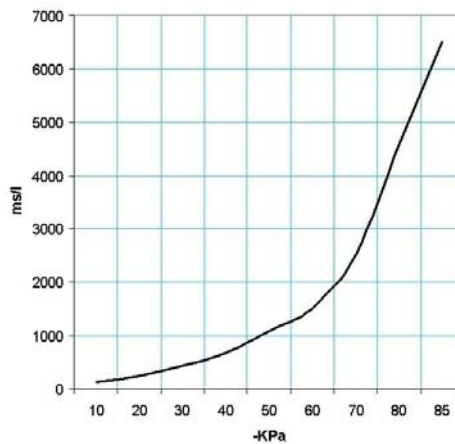

Generator art.	Supply press. bar (g)	Air consumption NI/s	Evacuation time (ms/l = s/m³) at different vacuum levels (-KPa)										Max. vacuum level -KPa
			10	20	30	40	50	60	70	80	85		
PVP 2	6.0	1.0	128	257	438	675	1087	1511	2523	4572	6492	85	

Accessories upon request

Silencer art. 00 15 74

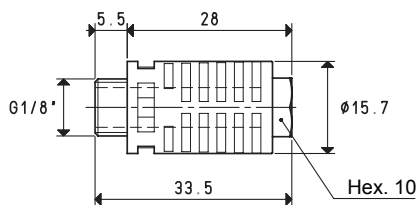

3D drawings available at www.vuototecnica.net

SINGLE-STAGE VACUUM GENERATORS PVP 3

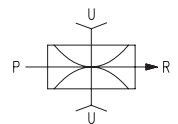
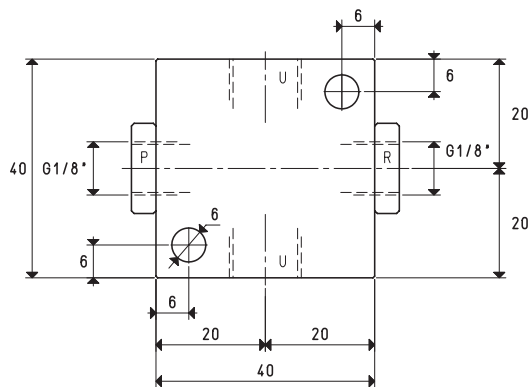
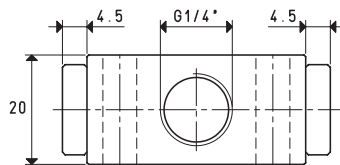

P=COMPRESSED AIR CONNECTION

R=EXHAUST

U=VACUUM CONNECTION

Art.	PVP 3			
Quantity of sucked air	cum/h	3.4	3.5	3.7
Max. vacuum level	-kPa	60	70	85
Final pressure	mbar abs.	400	300	150
Supply pressure	bar (g)	4	5	6
Air consumption	NI/s	1.1	1.3	1.5
Working temperature	°C			-20 / +80
Noise level	dB(A)			80
Weight	g			100

Note: All the vacuum data indicated in the table are valid at the normal atmospheric pressure of 1013 mbar and are obtained with a constant supply pressure.

Air capacity (NI/s) at different vacuum levels (-Kpa)

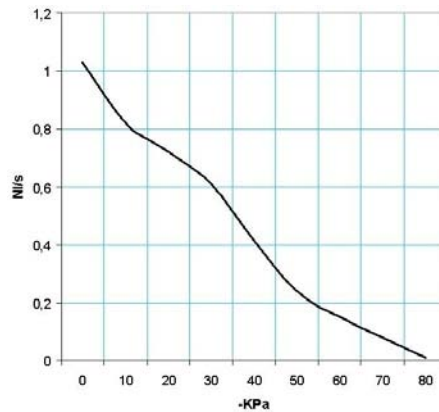

Generator art.	Supply press. bar (g)	Air consumption NI/s	Air capacity (NI/s) at different vacuum levels (-KPa)										Max. vacuum level -KPa
			0	10	20	30	40	50	60	70	80	85	
PVP 3	6.0	1.5	1.03	0.82	0.72	0.61	0.41	0.24	0.15	0.08	0.008	85	

Evacuation time (ms/l=s/m³) at different vacuum levels (-Kpa)

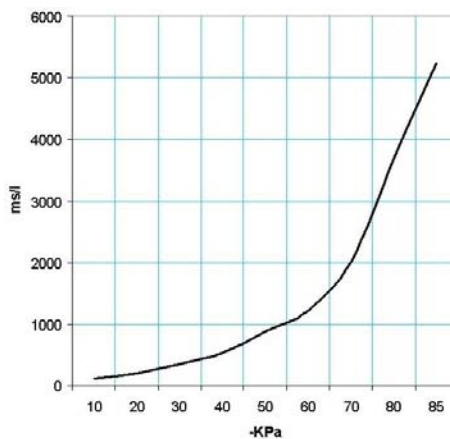

Generator art.	Supply press. bar (g)	Air consumption NI/s	Evacuation time (ms/l = s/m ³) at different vacuum levels (-KPa)										Max. vacuum level -KPa
			10	20	30	40	50	60	70	80	85		
PVP 3	6.0	1.5	104	207	353	544	857	1217	2033	3684	5232	85	

Accessories upon request

Silencer art. 00 15 74

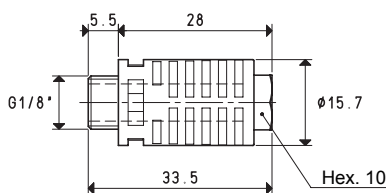

3D drawings available at www.vuototecnica.net

SINGLE-STAGE VACUUM GENERATORS PVP 2 M

The vacuum generators described in this page are also based on the Venturi principle and share the same technical features as the previous ones. Their distinctive feature is their shape.

The vacuum connection U, in fact, is threaded to allow the assembly of a vacuum cup with a male 3/8" threaded gas support, while in-line, but on the opposite side an M 10 threaded hole allows installing the generator directly onto the machine or on the cup holders with springing device. They are fully made with anodised aluminium, with brass ejectors.

Equipped with a vacuum cup, they are true independent gripping units.

These vacuum generators are suited for vacuum cup operated loaders or handlers, for gripping sheet steel, glass slabs, plastic panels and other similar products.

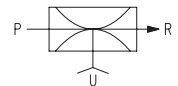
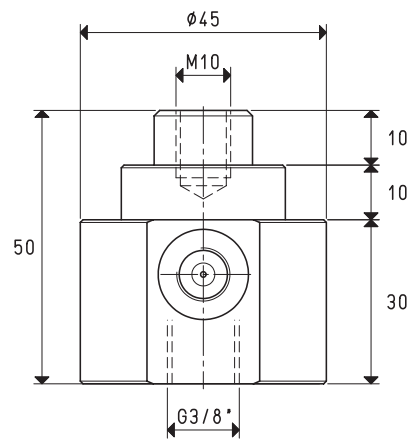
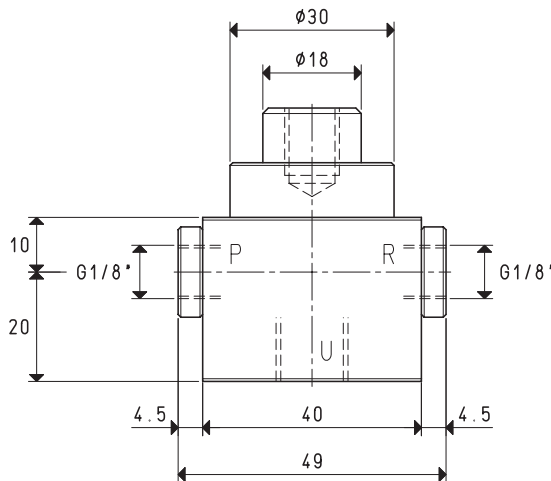

P=COMPRESSED AIR CONNECTION

R=EXHAUST

U=VACUUM CONNECTION

Art.	PVP 2 M			
Quantity of sucked air	cum/h	2.8	2.9	3.0
Max. vacuum level	-KPa	60	70	85
Final pressure	mbar abs.	400	300	150
Supply pressure	bar (g)	4	5	6
Air consumption	NI/s	0.7	0.9	1.0
Working temperature	°C			-20 / +80
Noise level	dB(A)			78
Weight	g			162

Note: All the vacuum data indicated in the table are valid at the normal atmospheric pressure of 1013 mbar and are obtained with a constant supply pressure.

Air capacity (NI/s) at different vacuum levels (-Kpa)

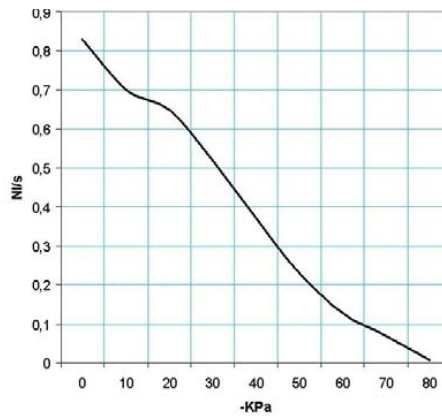

Generator art.	Supply press. bar (g)	Air consumption NI/s	Air capacity (NI/s) at different vacuum levels (-KPa)										Max. vacuum level -KPa
			0	10	20	30	40	50	60	70	80	85	
PVP 2 M	6.0	1.0	0.83	1.70	0.65	0.52	0.37	0.23	0.13	0.07	0.007	85	

Evacuation time (ms/l=s/m³) at different vacuum levels (-Kpa)

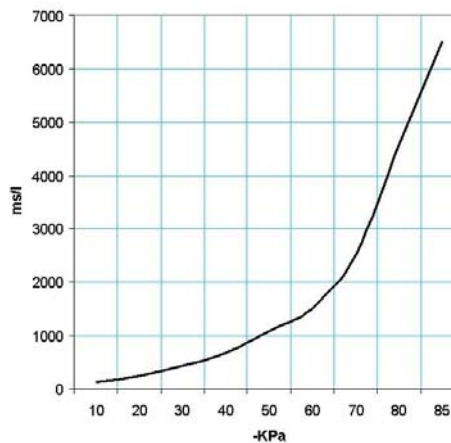

Generator art.	Supply press. bar (g)	Air consumption NI/s	Evacuation time (ms/l = s/m³) at different vacuum levels (-KPa)										Max. vacuum level -KPa
			10	20	30	40	50	60	70	80	85		
PVP 2 M	6.0	1.0	128	257	438	675	1087	1511	2523	4572	6492	85	

Accessories upon request

Silencer art. 00 15 74

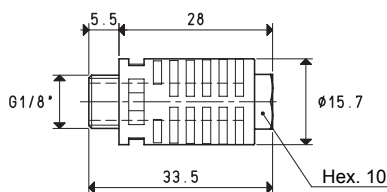

SINGLE-STAGE VACUUM GENERATORS PVP 7 X

Vacuum generators PVP 7 X also exploit the Venturi principle. Their distinctive feature compared to PVP 2 and PVP 3 is their greater suction capacity, thanks to the association of two ejectors in parallel.

A special silencer made with sintered ceramic is installed on their exhaust, making them particularly silent.

As a standard, they are equipped with a vacuum gauge for a direct reading of the vacuum level.

An additional connection on the body of the generator allows the installation of a mini vacuum switch for signalling the vacuum level, or of a pneumatic solenoid valve for a quick restoration of the atmospheric pressure at the service.

They are fully made with anodised aluminium, with stainless steel ejectors.

These vacuum generators can be used for connecting one or more vacuum cups or equipment with capacity requirements within the shown values.

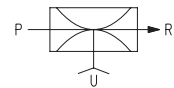
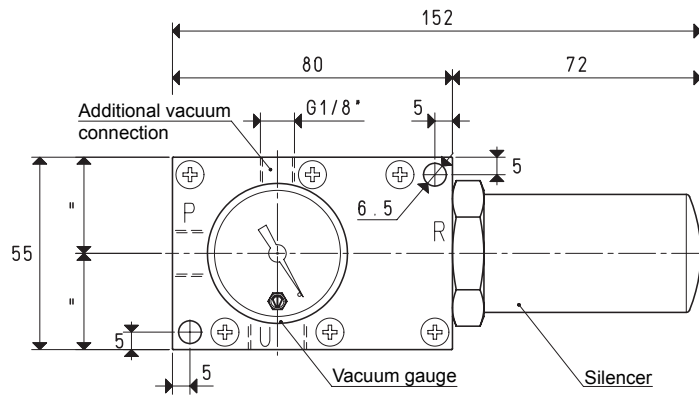
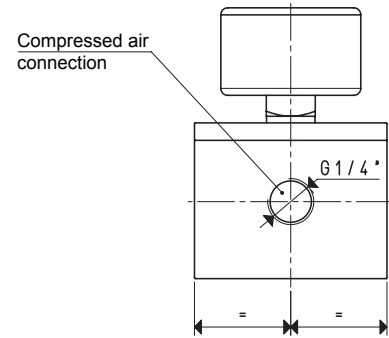
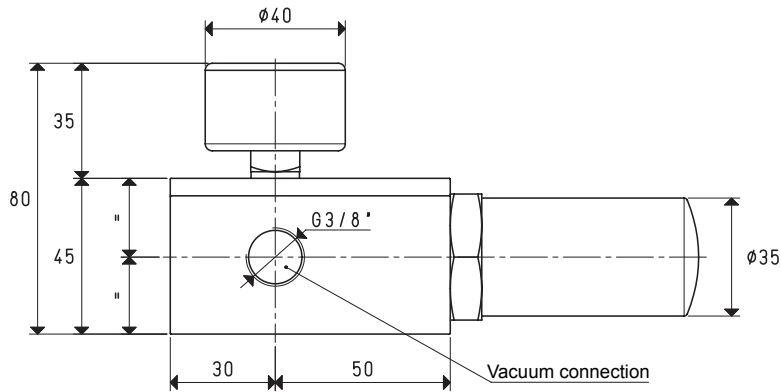

P=COMPRESSED AIR CONNECTION R=EXHAUST U=VACUUM CONNECTION

Art.	PVP 7 X			
Quantity of sucked air	cum/h	8.5	8.8	8.9
Max. vacuum level	-kPa	60	73	85
Final pressure	mbar abs.	400	270	150
Supply pressure	bar (g)	4	5	6
Air consumption	l/s	2.3	2.8	3.2
Working temperature	°C	-20 / +80		
Noise level	dB(A)	63		
Weight	g	470		
Spare parts				
Sealing kit	art.	00 15 276		
Vacuum gauge	art.	09 03 15		
Silencer	art.	00 15 55		

Note: All the vacuum data indicated in the table are valid at the normal atmospheric pressure of 1013 mbar and are obtained with a constant supply pressure.

3D drawings available at www.vuototecnica.net

Air capacity (NI/s) at different vacuum levels (-Kpa)

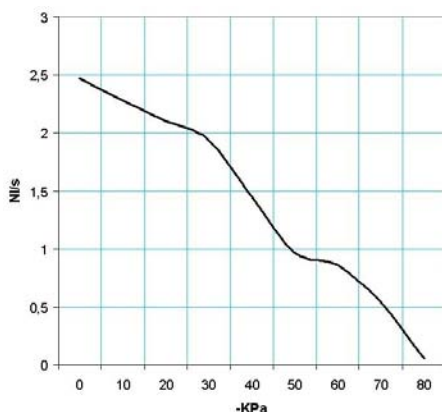

Generator art.	Supply press. bar (g)	Air consumption NI/s	Air capacity (NI/s) at different vacuum levels (-KPa)										Max. vacuum level -KPa
			0	10	20	30	40	50	60	70	80		
PVP 7 X	6.0	3.2	2.47	2.28	2.10	1.94	1.44	0.97	0.86	0.54	0.05	85	

Evacuation time (ms/l=s/m³) at different vacuum levels (-Kpa)

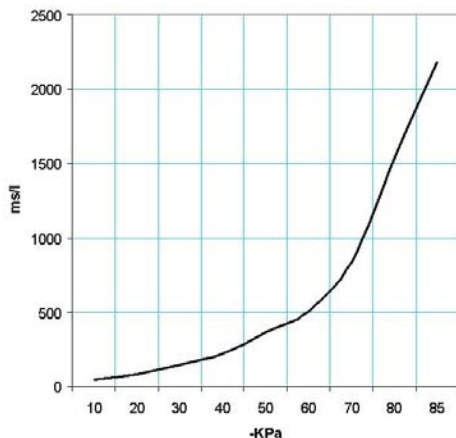

Generator art.	Supply press. bar (g)	Air consumption NI/s	Evacuation time (ms/l = s/m³) at different vacuum levels (-KPa)										Max. vacuum level -KPa
			10	20	30	40	50	60	70	80	85		
PVP 7 X	6.0	3.2	43	86	147	226	365	507	847	1536	2181	85	

SINGLE-STAGE VACUUM GENERATORS PVP 7 SX

Vacuum generators PVP 7X share the same mechanical and technical features as the previously described ones. Their distinctive feature is a state of the art silencer installed on them and made with natural fibre sound absorbing material contained in a special cylindrical anodised aluminium enclosure open on the exhaust.

This prevents the silencer from being clogged and allows the vacuum generator to suck oil or water condensation saturated fluids mixed with fine and impalpable dust.

They can be used as PVP 7X and, in addition, they can also operate in humid or dusty environments.

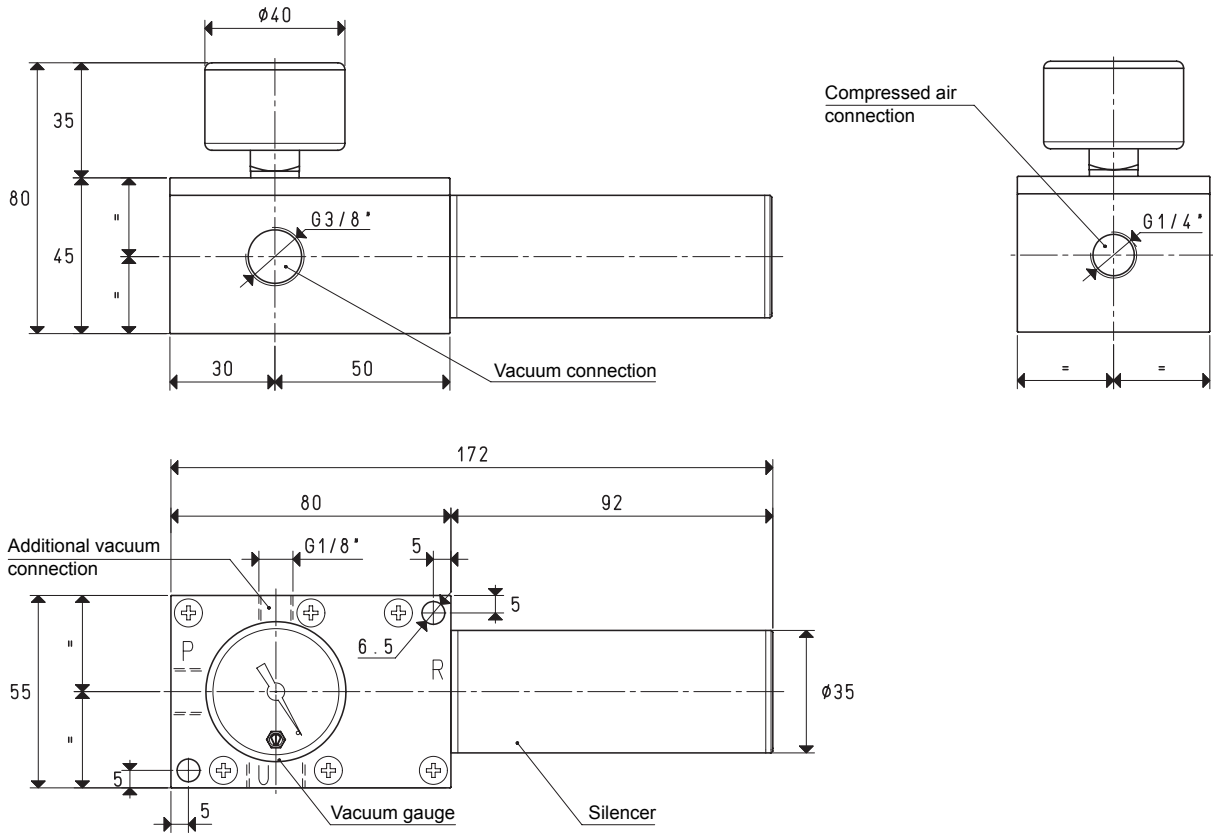

Art.	PVP 7 SX			
Quantity of sucked air	cum/h	8.5	8.8	8.9
Max. vacuum level	-kPa	60	73	85
Final pressure	mbar abs.	400	270	150
Supply pressure	bar (g)	4	5	6
Air consumption	l/s	2.3	2.8	3.2
Working temperature	°C	-20 / +80		
Noise level	dB(A)	63		
Weight	g	470		
Spare parts				
Sealing kit	art.	00 15 276		
Vacuum gauge	art.	09 03 15		
Silencer	art.	SSX 3/4 R		

Note: All the vacuum data indicated in the table are valid at the normal atmospheric pressure of 1013 mbar and are obtained with a constant supply pressure.

3D drawings available at www.vuototecnica.net

Air capacity (NI/s) at different vacuum levels (-Kpa)

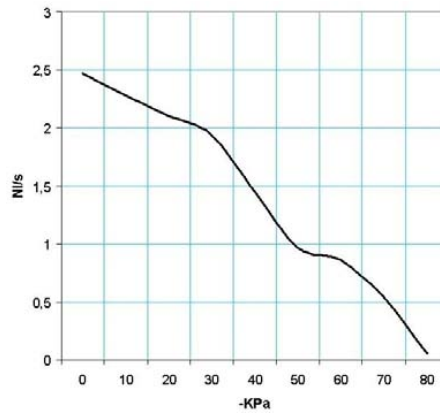

Generator art.	Supply press. bar (g)	Air consumption NI/s	Air capacity (NI/s) at different vacuum levels (-KPa)										Max. vacuum level -KPa
			0	10	20	30	40	50	60	70	80		
PVP 7 SX	6.0	3.2	2.47	2.28	2.10	1.94	1.44	0.97	0.86	0.54	0.05	85	

Evacuation time (ms/l=s/m³) at different vacuum levels (-Kpa)

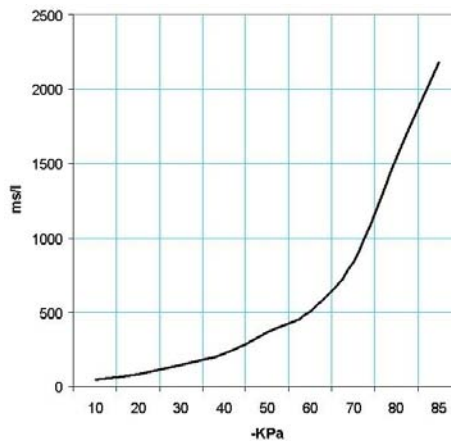

Generator art.	Supply press. bar (g)	Air consumption NI/s	Evacuation time (ms/l = s/m ³) at different vacuum levels (-KPa)										Max. vacuum level -KPa
			10	20	30	40	50	60	70	80	85		
PVP 7 SX	6.0	3.2	43	86	147	226	365	507	847	1536	2181	85	

FIXING SUPPORTS FOR SINGLE-STAGE VACUUM GENERATORS

The supports described in this page are made with anodised aluminium as a standard, but, upon request, they can be supplied in the stainless steel version. These supports are for fixing the single-stage vacuum generators to the machine via a cylindrical slotted pin or a ball pin housed in the machine itself. They are suited for robotic gripping systems and they allow for an easy installation of the vacuum generators on the profiles used in the automotive sector.

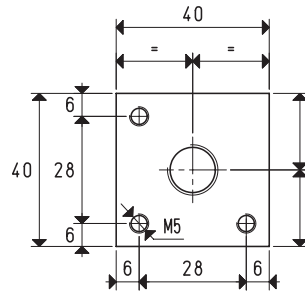
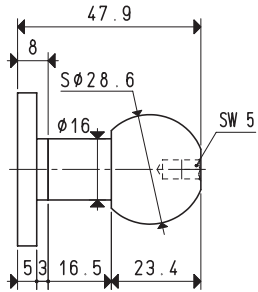

Art.	For generators	Material	Weight g
FCH 01	PVP 2	aluminium	60
	PVP 3		
FCH 01 INOX	PVP 2	stainless steel	180
	PVP 3		

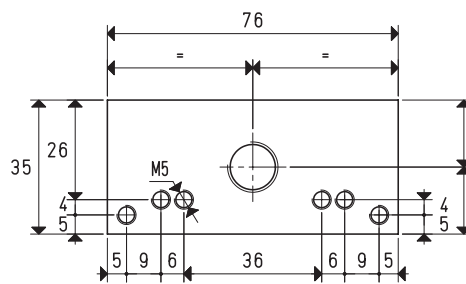
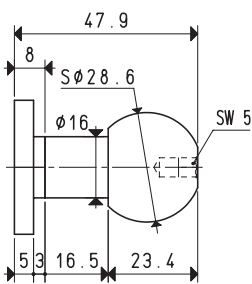

Art.	For generators	Material	Weight g
FCH 02	15 01 10	aluminium	72
	15 02 10		
	15 03 10		
	15 04 10		
FCH 02 INOX	15 01 10	stainless steel	220
	15 02 10		
	15 03 10		
	15 04 10		

3D drawings available at www.vuototecnica.net

FIXING SUPPORTS FOR SINGLE-STAGE VACUUM GENERATORS

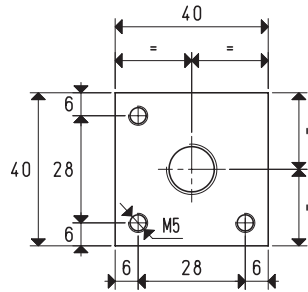
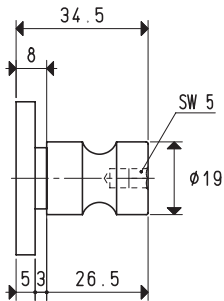

Art.	For generators	Material	Weight
FCH 03	PVP 2	aluminium	9
	PVP 3		39
FCH 03 INOX	PVP 2	stainless steel	117
	PVP 3		

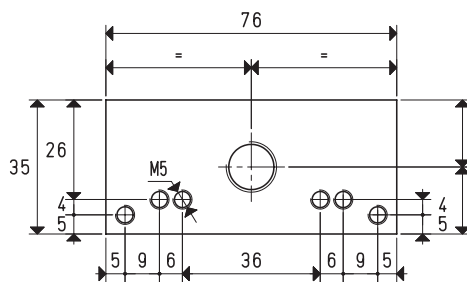
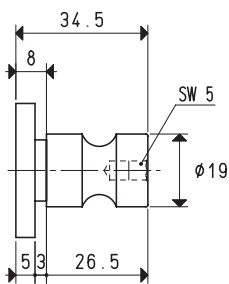

Art.	For generators	Material	Weight
FCH 04	15 01 10	aluminium	52
	15 02 10		
	15 03 10		
	15 04 10		
FCH 04 INOX	15 01 10	stainless steel	156
	15 02 10		
	15 03 10		
	15 04 10		

Conversion ratio: inch = $\frac{mm}{25.4}$ · pounds = $\frac{g}{453.6}$ = $\frac{Kg}{0.4536}$

MULTI-STAGE VACUUM GENERATORS - GENERAL INFORMATION

Our multi-stage vacuum generators produce a maximum vacuum of 90%, equal to a final vacuum level of 100 mbar abs., with different suction capacities. They operate by use of compressed air from 1 to 6 bar (g).

Working principle

Each ejector is based on the Venturi principle: the supply fluid (compressed air) is led high speed by a convergent pipe into the fluid to be extracted (volume of the air to be sucked). This mixture is then led into two or three divergent pipes, where its kinetic energy is transformed into pressure energy for it to enter in the environment at a higher pressure (atmospheric pressure at the exhaust).

Technical features

The main asset of multi-stage vacuum generators is its ability to exploit the kinetic energy of the supply compressed air via several specially dimensioned in-line ejectors, before releasing it in the atmosphere. This system allows, given the same capacity, a reduced compressed air consumption compared to the single-stage vacuum generators.

The suction capacity is indirectly proportional to the differential between the pressure of the fluid to be sucked and the external (atmospheric) pressure.

The reduced size and weight make multi-stage vacuum generators compact in relation to their great suction capacity.

The absence of moving parts make them particularly silent and allow them to be used continuously, without developing heat.

Being supplied exclusively by compressed air, these vacuum generators are explosion-proof and can be used in work environments with temperatures ranging from -20 to +80 °C.

They are fully made with stainless materials.

Thanks to all these features, a good filtration of the supply and sucked compressed air is sufficient to make these generators are fully maintenance-free.

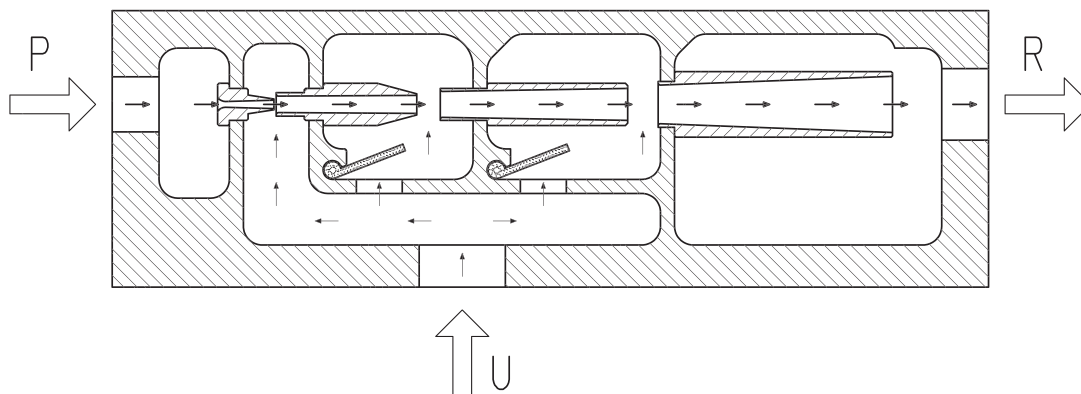

P = Compressed air connection

R = Exhaust

U = Vacuum connection

MULTI-STAGE VACUUM GENERATORS SERIES M

These vacuum generators feature multiple state of the art ejectors assembled onto small modules. One of their distinctive features is their great suction capacity compared to their reduced size.

With a compressed air supply of 4 ÷ 5 bar (g), they can produce a maximum vacuum equal to 85% and a suction capacity of 3.6 ÷ 18 cum/h, according to the number of modules.

The silencer is built-in.

They are fully made with slightly anodised alloys and can be installed in any position. The multi-stage vacuum generators in this range are suited for interconnecting vacuum cup gripping systems and, in particular, in the industrial robotics sector, which requires equipment with excellent working performance, but with weight and size reduced to the minimum.

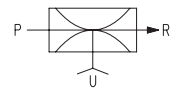
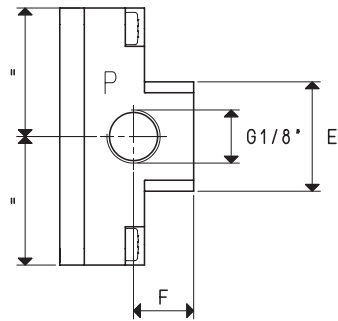
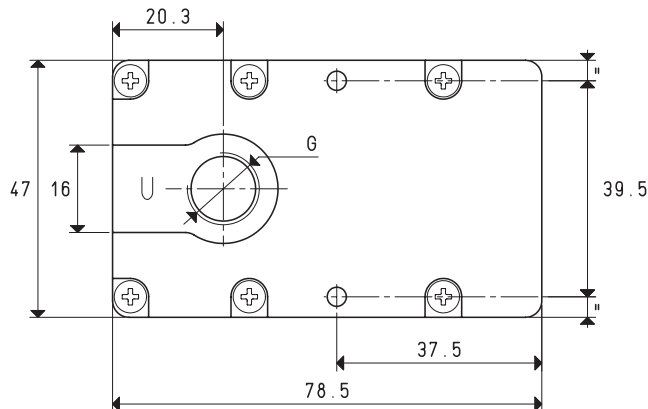
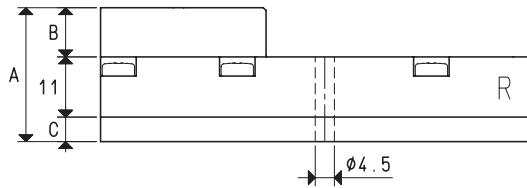

P=COMPRESSED AIR CONNECTION R=EXHAUST U=VACUUM CONNECTION

Art.		M 3					M 7	
Quantity of sucked air	cum/h	3	3.4	3.6	5.4	5.8	6.2	
Max. vacuum level	-KPa	62	82	85	62	82	85	
Final pressure	mbar abs.	380	180	150	380	180	150	
Supply pressure	bar (g)	3	4	5	3	4	5	
Air consumption	NI/s	0.5	0.7	0.8	0.8	1.2	1.4	
Working temperature	°C			-10 / +80			-10 / +80	
Noise level	dB(A)			64			70	
Weight	g			109			111	
A				24.5			25.5	
B				9			10	
C				4.5			4.5	
E	∅			20			24	
F				11			12	
G	∅			G1/4"			G3/8"	
Spare parts								
Sealing kit and reed valve	art.			00 KIT M 3			00 KIT M 7	

Note: All the vacuum data indicated in the table are valid at the normal atmospheric pressure of 1013 mbar and are obtained with a constant supply pressure.

Conversion ratio: inch = $\frac{\text{mm}}{25.4}$; pounds = $\frac{\text{g}}{453.6}$ = $\frac{\text{Kg}}{0.4536}$

GAS-NPT thread adapters available at page 1.117

MULTI-STAGE VACUUM GENERATORS M 3 and M 7

Air capacity (NI/s) at different vacuum levels (-Kpa)

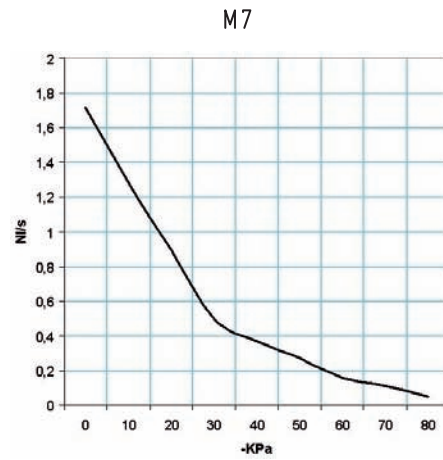
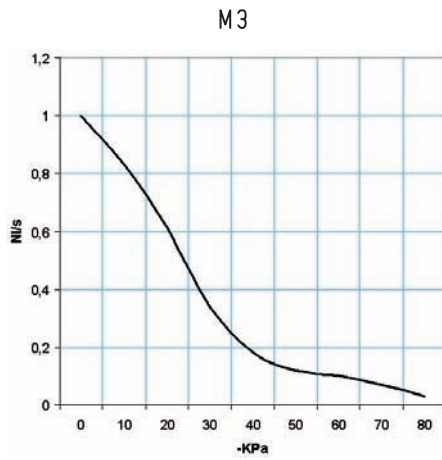

Generator art.	Supply press. bar (g)	Air consumption NI/s	Air capacity (NI/s) at different vacuum levels (-KPa)										Max. vacuum level -KPa
			0	10	20	30	40	50	60	70	80		
M 3	5.0	0.8	1.00	0.83	0.61	0.34	0.18	0.12	0.10	0.07	0.03	85	
M 7	5.0	1.4	1.72	1.28	0.89	0.50	0.37	0.27	0.16	0.11	0.05	85	

Evacuation time (ms/l=s/m³) at different vacuum levels (-Kpa)

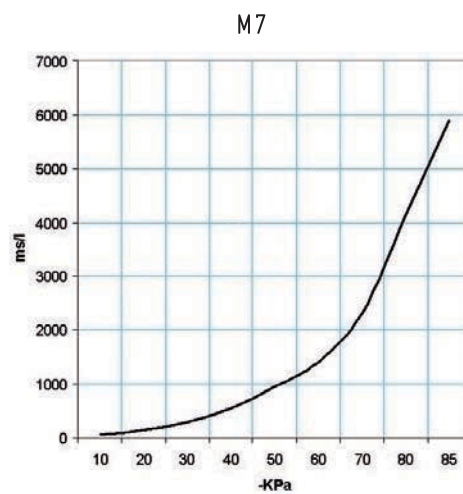
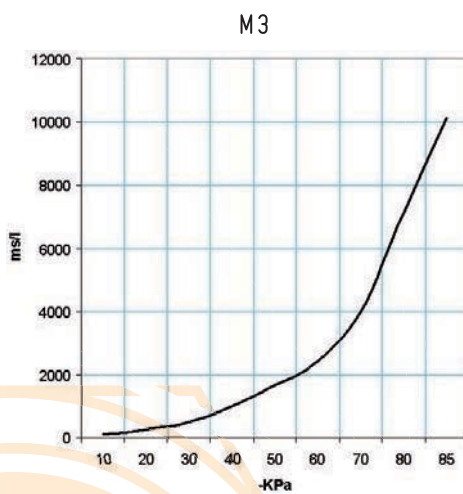

Generator art.	Supply press. bar (g)	Air consumption NI/s	Evacuation time (ms/l = s/m ³) at different vacuum levels (-KPa)								Max. vacuum level -KPa	
			10	20	30	40	50	60	70	80		85
M 3	5.0	0.8	106	244	491	969	1642	2398	4004	7128	10122	85
M 7	5.0	1.4	61	142	285	563	954	1394	2328	4144	5885	85

MULTI-STAGE VACUUM GENERATORS M 10, M 14 and M 18

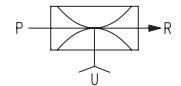
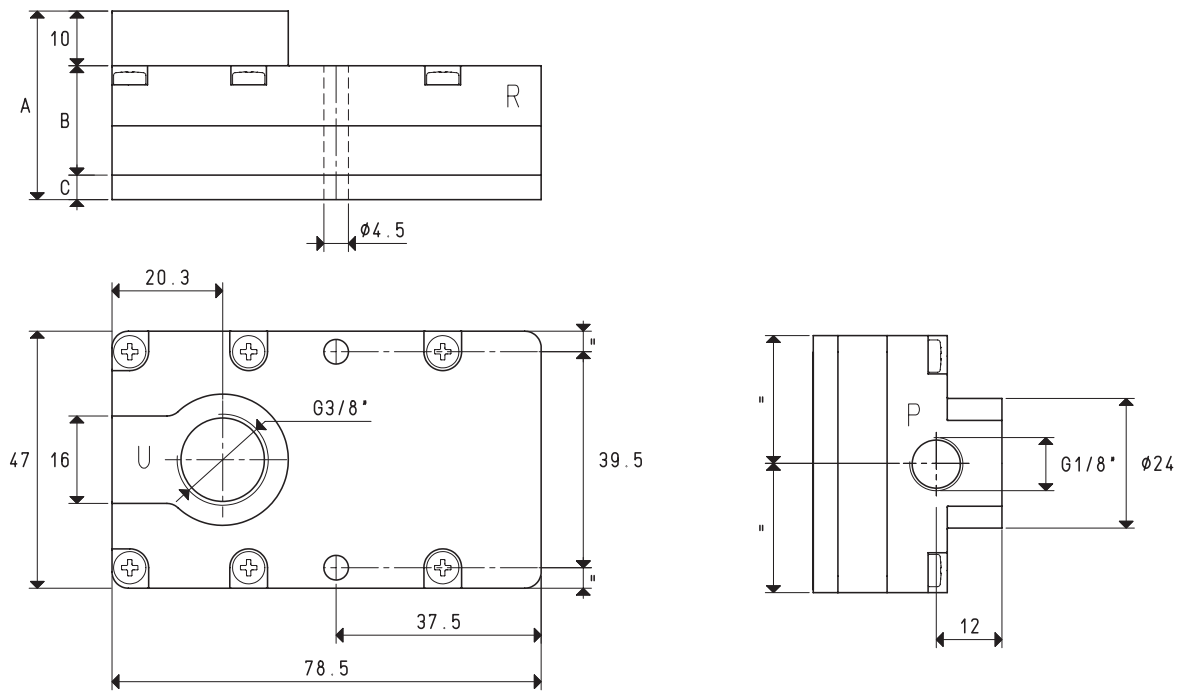
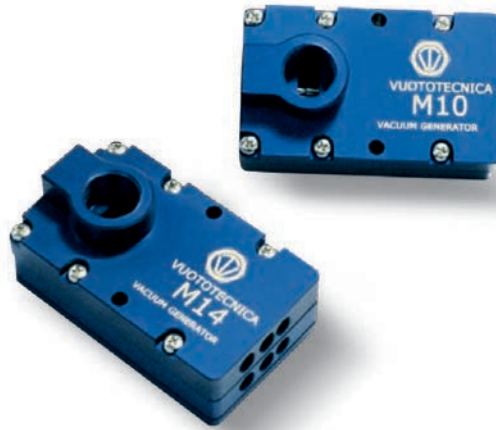

P=COMPRESSED AIR CONNECTION R=EXHAUST U=VACUUM CONNECTION

Art.		M 10					M 14			M 18	
Quantity of sucked air	cum/h	7.7	8.5	9.4	10.2	11.6	12.6	14.8	16.5	18.0	
Max. vacuum level	-KPa	62	82	85	62	82	85	62	82	85	
Final pressure	mbar abs.	380	180	150	380	180	150	380	180	150	
Supply pressure	bar (g)	3	4	5	3	4	5	3	4	5	
Air consumption	NI/s	1.2	1.6	1.9	1.7	2.1	2.5	2.3	2.9	3.6	
Working temperature	°C			-10 / +80			-10 / +80			-10 / +80	
Noise level	dB(A)			72			72			76	
Weight	g			144			145			150	
A				34.5			34.5			44.5	
B				20			20			30	
C				4.5			4.5			4.5	
Spare parts											
Sealing kit and reed valve	art.			00 KIT M 10			00 KIT M 14			00 KIT M 18	

Note: All the vacuum data indicated in the table are valid at the normal atmospheric pressure of 1013 mbar and are obtained with a constant supply pressure.

Conversion ratio: inch = $\frac{mm}{25.4}$; pounds = $\frac{g}{453.6}$ = $\frac{Kg}{0.4536}$

GAS-NPT thread adapters available at page 1.117

MULTI-STAGE VACUUM GENERATORS M 10, M 14 and M 18

Air capacity (NI/s) at different vacuum levels (-KPa)

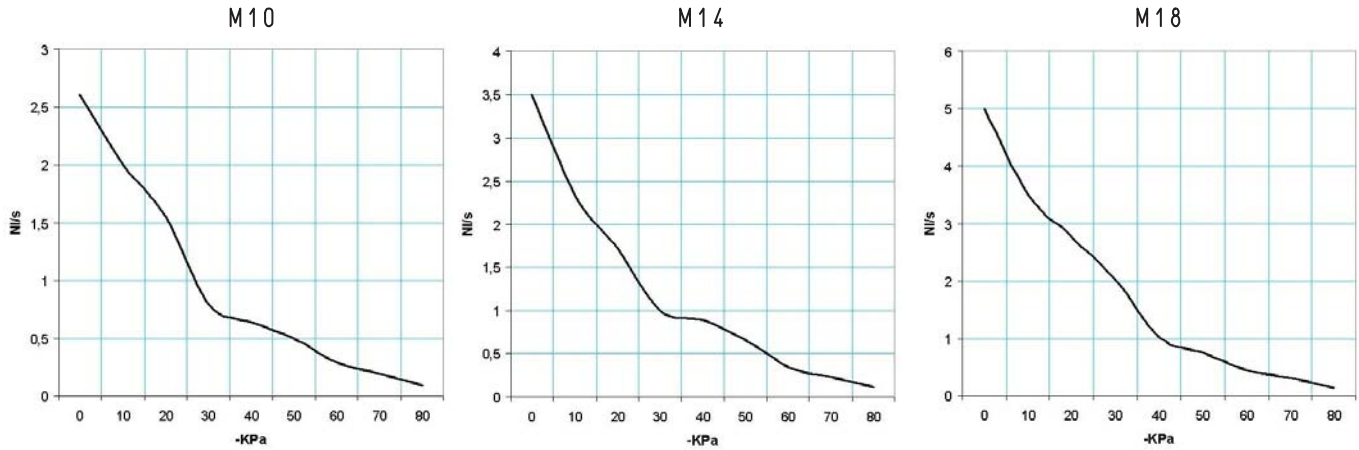

Generator art.	Supply press. bar (g)	Air consumption NI/s	Air capacity (NI/s) at different vacuum levels (-KPa)										Max. vacuum level -KPa
			0	10	20	30	40	50	60	70	80		
M 10	5.0	1.9	2.61	2.00	1.55	0.80	0.64	0.50	0.29	0.19	0.09	0.09	85
M 14	5.0	2.5	3.50	2.33	1.72	1.00	0.89	0.67	0.35	0.24	0.11	0.11	85
M 18	5.0	3.6	5.00	3.50	2.78	2.02	1.02	0.75	0.44	0.30	0.14	0.14	85

Evacuation time (ms/l=s/m³) at different vacuum levels (-KPa)

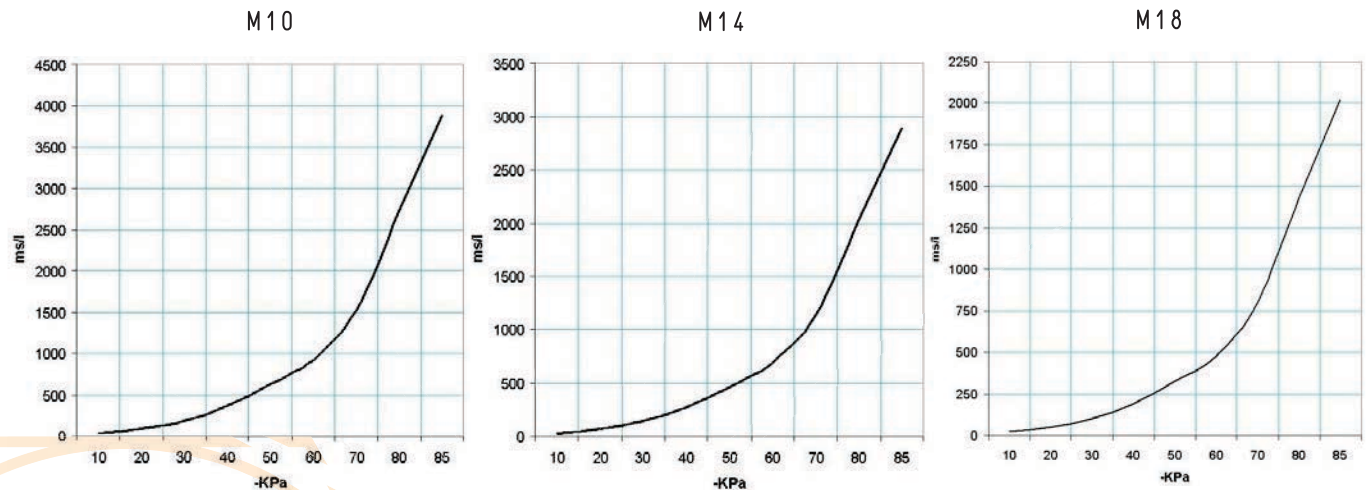

Generator art.	Supply press. bar (g)	Air consumption NI/s	Evacuation time (ms/l = s/m ³) at different vacuum levels (-KPa)										Max. vacuum level -KPa
			10	20	30	40	50	60	70	80	85		
M 10	5.0	1.9	40	93	188	371	629	918	1534	2731	3878	3878	85
M 14	5.0	2.5	30	69	140	276	469	685	1144	2036	2892	2892	85
M 18	5.0	3.6	21	48	98	193	327	478	799	1423	2020	2020	85

MULTI-STAGE VACUUM GENERATORS SERIES M.. SSX

These vacuum generators share the same technical features as the others of the M series described above. Their distinctive feature is their silent operation.

In fact, along with the built-in silencer, they also have an external SSX silencer for a further noise reduction.

These generators are particularly recommended in work environments where the noise level must be kept within very low values.

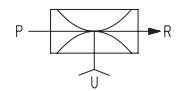
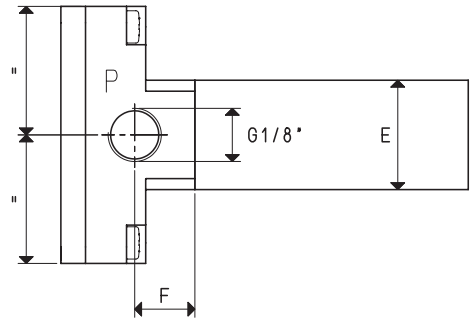
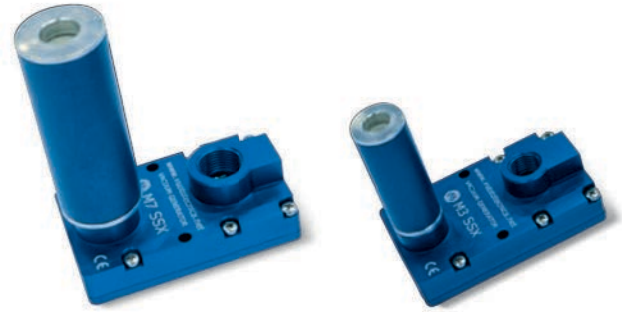
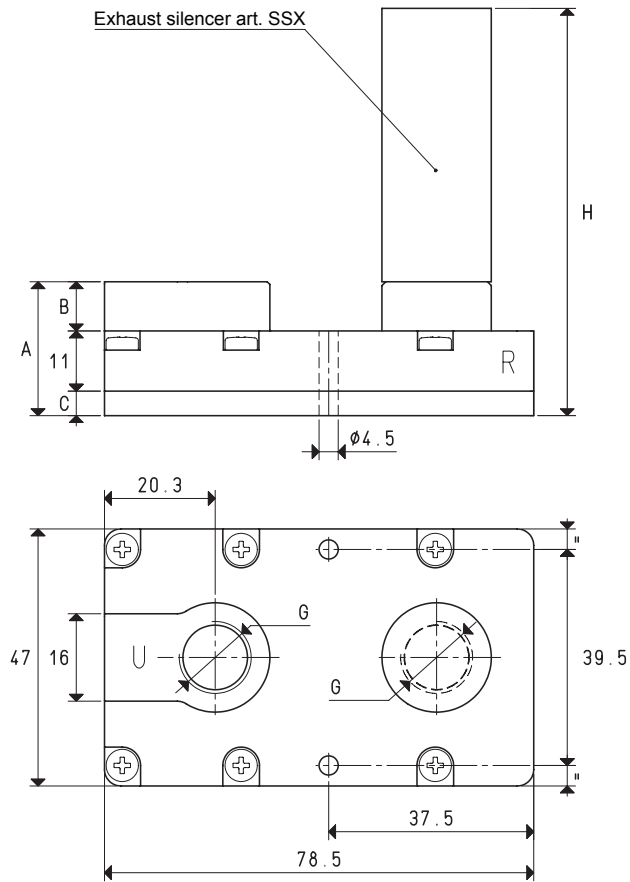

P=COMPRESSED AIR CONNECTION R=EXHAUST U=VACUUM CONNECTION

Art.				M 3 SSX			M 7 SSX
Quantity of sucked air	cum/h	3.0	3.4	3.6	5.4	5.8	6.2
Max. vacuum level	-KPa	62	82	85	62	82	85
Final pressure	mbar abs.	380	180	150	380	180	150
Supply pressure	bar (g)	3	4	5	3	4	5
Air consumption	NI/s	0.5	0.7	0.8	0.8	1.2	1.4
Working temperature	°C			-10 / +80			-10 / +80
Noise level	dB(A)			52			58
Weight	g			109			111
A				24.5			25.5
B				9			10
C				4.5			4.5
E	∅			20			29
F				11			12
G	∅			G1/4"			G3/8"
H				74.5			97.5
Spare parts							
Silencer	art.			SSX 1/4"			SSX 3/8"
Sealing kit and reed valve	art.			00 KIT M 3			00 KIT M 7

Note: All the vacuum data indicated in the table are valid at the normal atmospheric pressure of 1013 mbar and are obtained with a constant supply pressure.

Conversion ratio: inch = $\frac{mm}{25.4}$; pounds = $\frac{g}{453.6}$ = $\frac{Kg}{0.4536}$

GAS-NPT thread adapters available at page 1.117

MULTI-STAGE VACUUM GENERATORS M 3 SSX and M 7 SSX

Air capacity (NI/s) at different vacuum levels (-Kpa)

M3 SSX

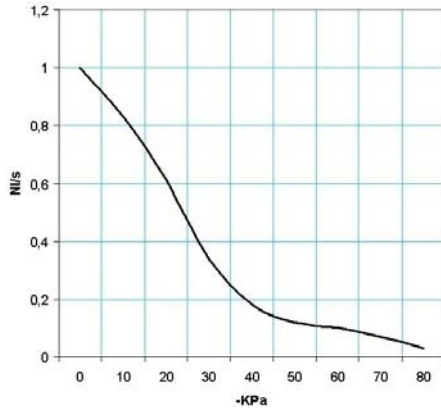

M7 SSX

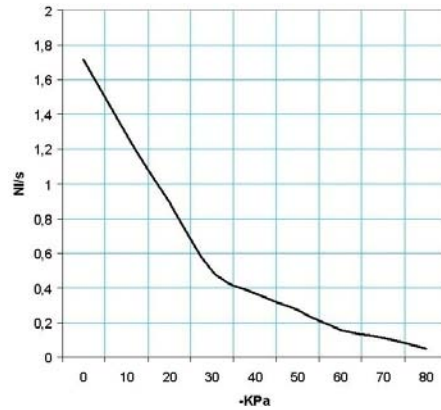

Generator art.	Supply press. bar (g)	Air consumption NI/s	Air capacity (NI/s) at different vacuum levels (-KPa)										Max. vacuum level -KPa
			0	10	20	30	40	50	60	70	80	85	
M 3 SSX	5.0	0.8	1.00	0.83	0.61	0.34	0.18	0.12	0.10	0.07	0.03	85	
M 7 SSX	5.0	1.4	1.72	1.28	0.89	0.50	0.37	0.27	0.16	0.11	0.05	85	

Evacuation time (ms/l=s/m³) at different vacuum levels (-Kpa)

M3 SSX

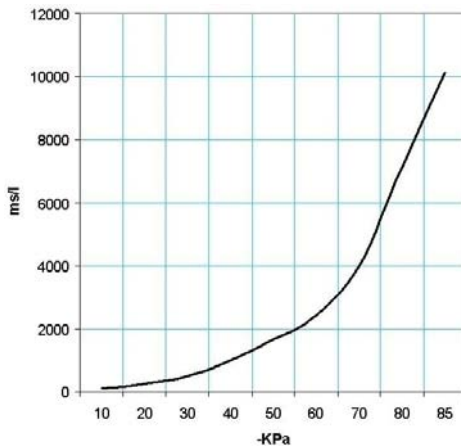

M7 SSX

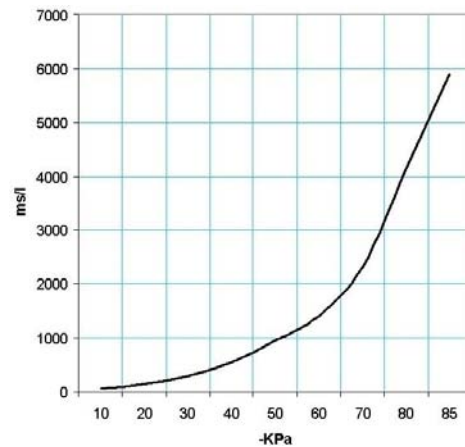

Generator art.	Supply press. bar (g)	Air consumption NI/s	Evacuation time (ms/l = s/m³) at different vacuum levels (-KPa)										Max. vacuum level -KPa
			10	20	30	40	50	60	70	80	85		
M 3 SSX	5.0	0.8	106	244	491	969	1642	2398	4004	7128	10122	85	
M 7 SSX	5.0	1.4	61	142	285	563	954	1394	2328	4144	5885	85	

Accessories included

Silencer art. SSX 1/4" on M3

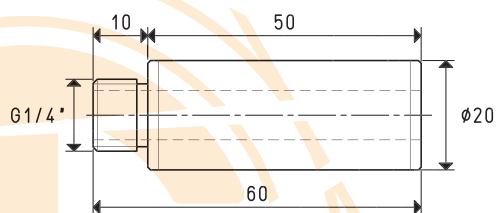

Silencer art. SSX 3/8" on M7

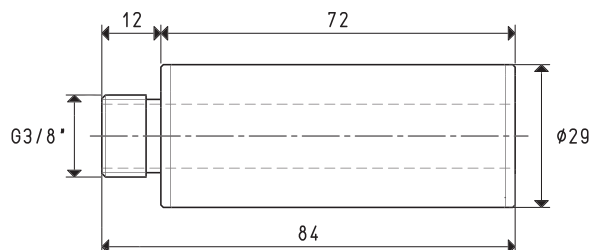

MULTI-STAGE VACUUM GENERATORS M 10 SSX, M 14 SSX and M 18 SSX

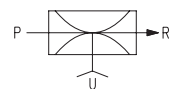
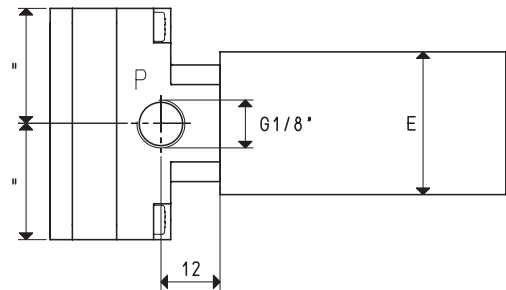
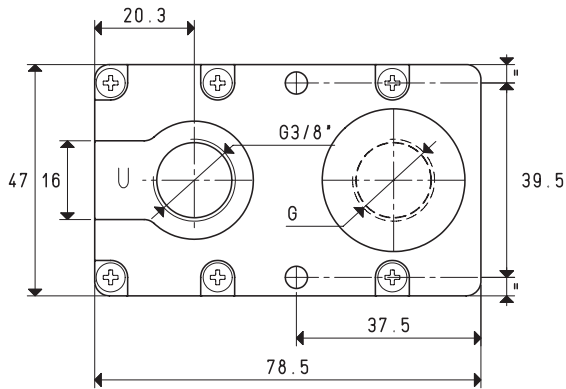
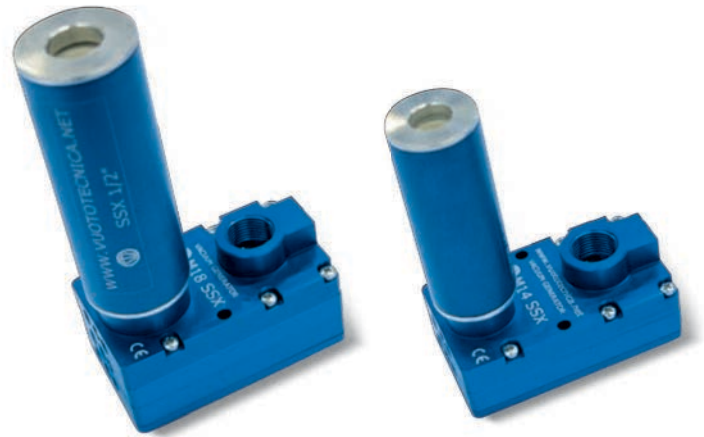
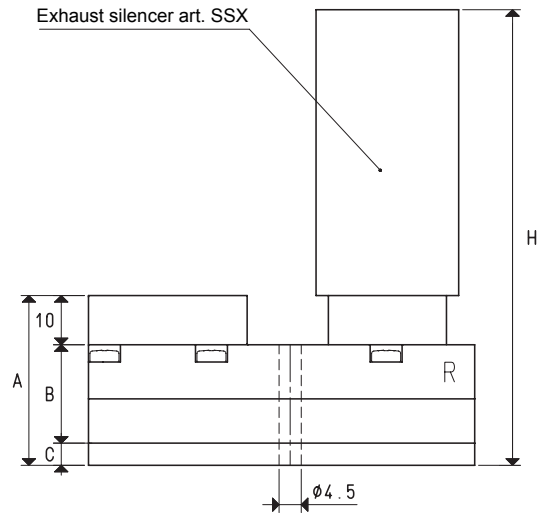

Art.	P=COMPRESSED AIR CONNECTION		R=EXHAUST		U=VACUUM CONNECTION					
					M 10 SSX		M 14 SSX		M 18 SSX	
Quantity of sucked air	cum/h	7.7	8.5	9.4	10.2	11.5	12.6	14.8	16.5	18.0
Max. vacuum level	-KPa	62	82	85	62	82	85	62	82	85
Final pressure	mbar abs.	380	180	150	380	180	150	380	180	150
Supply pressure	bar (g)	3	4	5	3	4	5	3	4	5
Air consumption	NI/s	1.2	1.6	1.9	1.7	2.1	2.5	2.3	2.9	3.6
Working temperature	°C			-10 / +80			-10 / +80			-10 / +80
Noise level	dB(A)			60			62			66
Weight	g			144			145			150
A				34.5			34.5			44.5
B				20			20			30
C				4.5			4.5			4.5
E	∅			29			29			35
G	∅			G3/8"			G3/8"			G1/2"
H				106.5			106.5			136.5
Spare parts										
Silencer	art.			SSX 3/8"			SSX 3/8"			SSX 1/2"
Sealing kit and reed valve	art.			00 KIT M 10			00 KIT M 14			00 KIT M 18

Note: All the vacuum data indicated in the table are valid at the normal atmospheric pressure of 1013 mbar and are obtained with a constant supply pressure.

Conversion ratio: inch = $\frac{mm}{25.4}$; pounds = $\frac{g}{453.6}$ = $\frac{Kg}{0.4536}$

GAS-NPT thread adapters available at page 1.117

MULTI-STAGE VACUUM GENERATORS M 10 SSX, M 14 SSX and M 18 SSX

Air capacity (NI/s) at different vacuum levels (-Kpa)

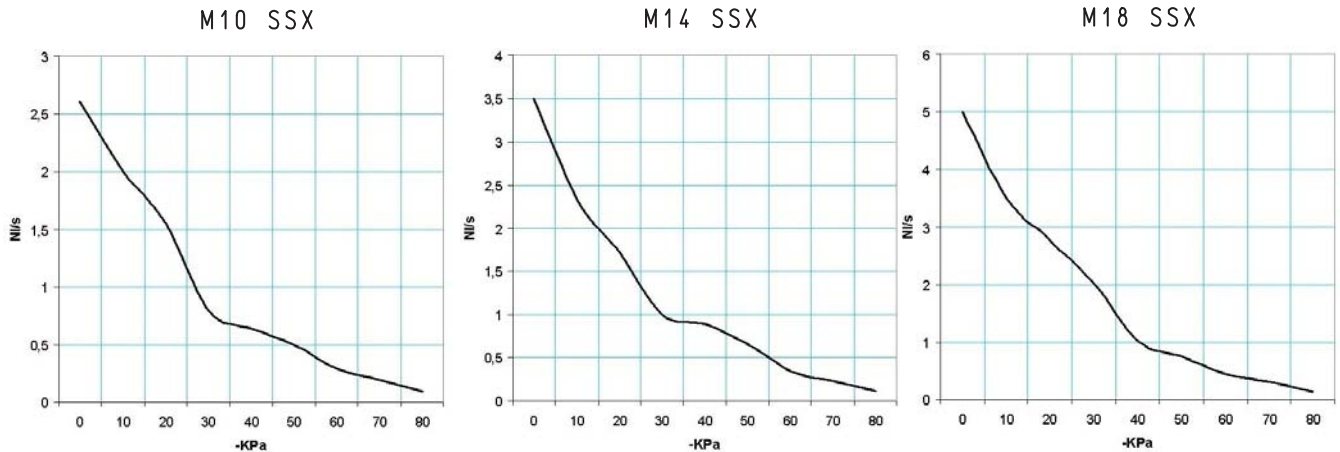

Generator art.	Supply press. bar (g)	Air consumption NI/s	Air capacity (NI/s) at different vacuum levels (-KPa)										Max. vacuum level -KPa
			0	10	20	30	40	50	60	70	80	85	
M 10 SSX	5.0	1.9	2.61	2.00	1.55	0.80	0.64	0.50	0.29	0.19	0.09	0.09	85
M 14 SSX	5.0	2.5	3.50	2.33	1.72	1.00	0.89	0.67	0.35	0.24	0.11	0.11	85
M 18 SSX	5.0	3.6	5.00	3.50	2.78	2.02	1.02	0.75	0.44	0.30	0.14	0.14	85

Evacuation time (ms/l=s/m³) at different vacuum levels (-Kpa)

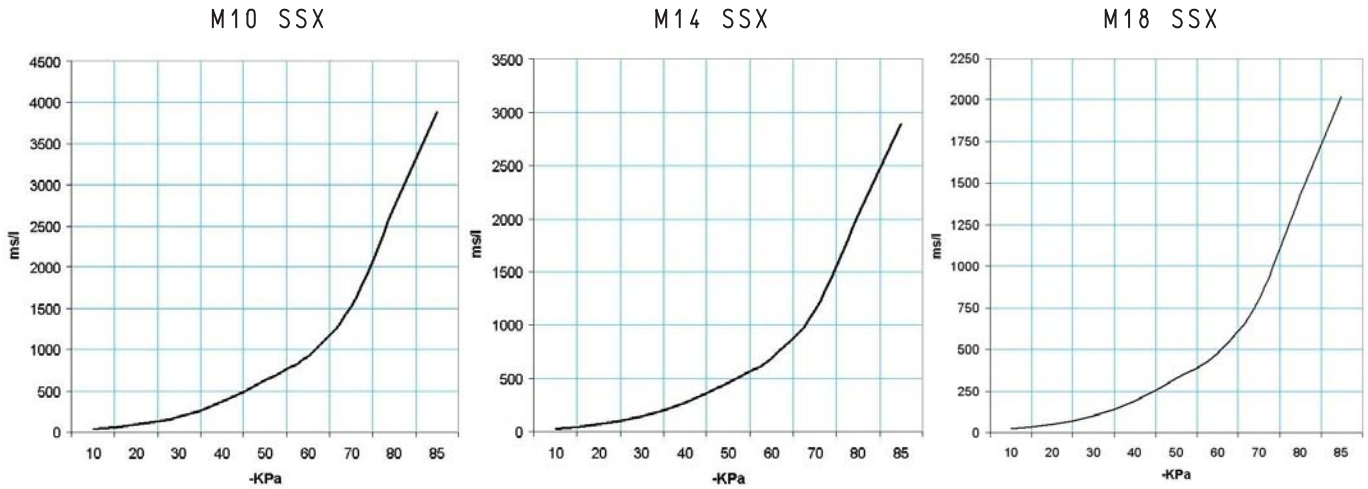

Generator art.	Supply press. bar (g)	Air consumption NI/s	Evacuation time (ms/l = s/m³) at different vacuum levels (-KPa)										Max. vacuum level -KPa
			10	20	30	40	50	60	70	80	85		
M 10 SSX	5.0	1.9	40	93	188	371	629	918	1534	2731	3878	3878	85
M 14 SSX	5.0	2.5	30	69	140	276	469	685	1144	2036	2892	2892	85
M 18 SSX	5.0	3.6	21	48	98	193	327	478	799	1423	2020	2020	85

Accessories included

Silencer art. SSX 1/2" on M10 and M14

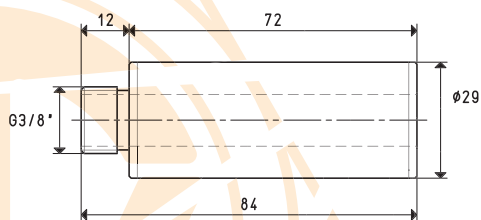

Silencer art. SSX 1/2" on M18

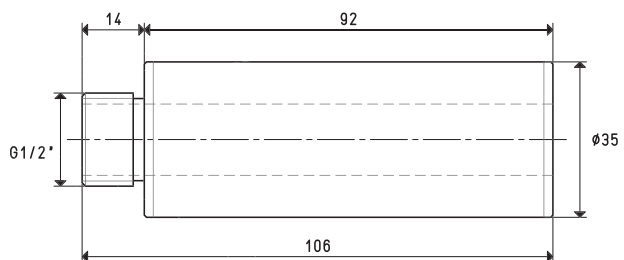

3D drawings available at www.vuototecnica.net

FIXING SUPPORTS FOR MULTI-STAGE VACUUM GENERATORS

The supports described in this page are made with anodised aluminium as a standard, but, upon request, they can be supplied in the stainless steel version. These supports are for fixing the multi-stage vacuum generators to the machine via a cylindrical slotted pin or a ball pin housed in the machine itself. They are suited for robotic gripping systems and they allow for an easy installation of the vacuum generators on the profiles used in the automotive sector.

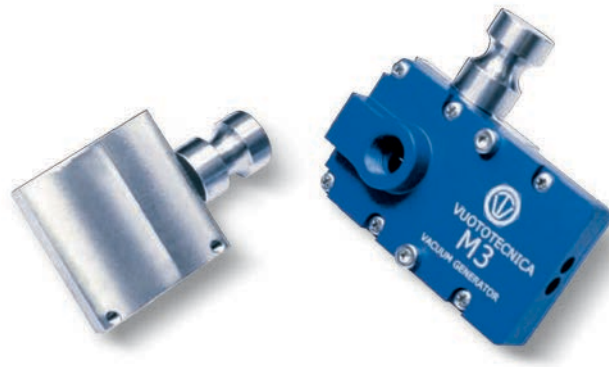
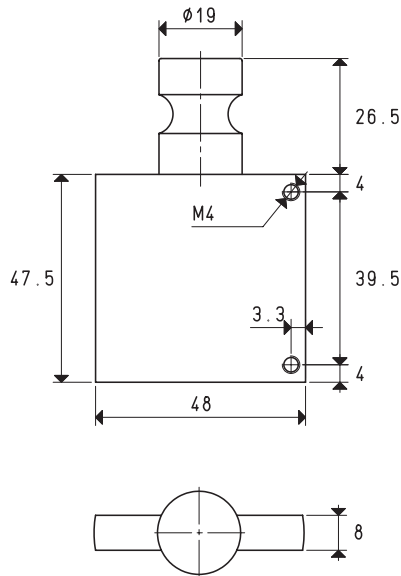

Art.	For generators	Material	Weight g
00 FCH 23	M 3 - M 7 - M 10 - M 14 - M 18	aluminium	63
00 FCH 22	M 3 - M 7 - M 10 - M 14 - M 18	stainless steel	191

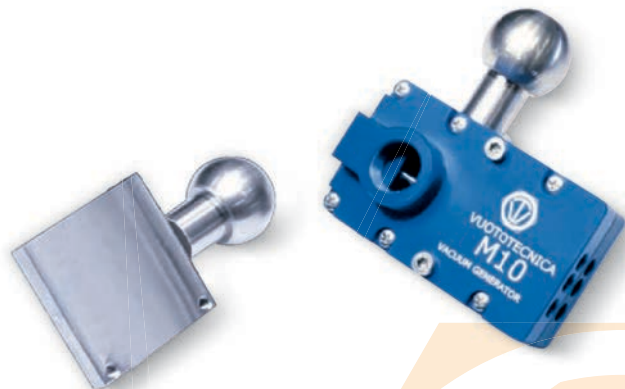
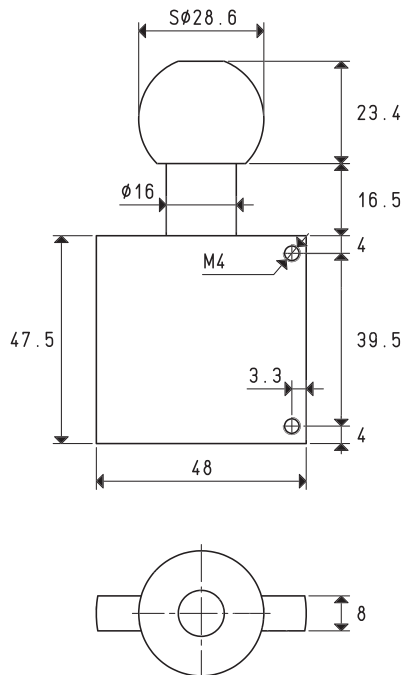

Art.	For generators	Material	Weight g
00 FCH 13	M 3 - M 7 - M 10 - M 14 - M 18	aluminium	85
00 FCH 12	M 3 - M 7 - M 10 - M 14 - M 18	stainless steel	256

Conversion ratio: inch = $\frac{\text{mm}}{25.4}$; pounds = $\frac{\text{g}}{453.6}$ = $\frac{\text{Kg}}{0.4536}$

MULTI-STAGE AND MULTI-FUNCTION VACUUM GENERATORS SERIES MVG

These generators are true independent vacuum units that can control an entire vacuum gripping system. Their distinctive features are their compact size and great suction capacity.

They are composed of a monobloc anodised aluminium structure onto which are assembled:

- A modular and silenced multi-stage vacuum generator.
- A micro solenoid valve for supplying compressed air to the generator.
- A micro solenoid valve for blowing the exhaust compressed air.
- An adjustable flow regulator for dosing the exhaust air.
- A unidirectional check valve, located on the suction inlet, for maintaining the vacuum in case of electricity failure.
- A digital vacuum switch provided with display and commutation LEDs, for managing the compressed air supply and for signalling the safety cycle start-up.
- An anodised aluminium manifold provided with vacuum connections and a built-in filter easy to inspect.

By activating the compressed air solenoid valve, the generator creates vacuum at the service. Once the preset maximum value is reached, the vacuum switch acts on the solenoid valve electric coil and interrupts the air supply, restoring it when the vacuum value returns below the minimum value.

Along with maintaining the vacuum level within preset safety values (hysteresis), this modulation allows saving a considerable amount of compressed air.

A second vacuum switch signal, also adjustable and independent from the first, can be used to start up the cycle when the vacuum level is suitable for the application. Once the working cycle is completed, the compressed air supply is deactivated and, at the same time, the ejection micro solenoid valve is activated for a quick restoration of the atmospheric pressure at the application.

MVG multi-function vacuum generators can be installed in any position and are suited for interconnecting vacuum gripping systems for handling sheet steel, glass, marble, ceramic, plastic, cardboard, wood, etc., and, in particular, for the industrial robotics sector which requires equipment with excellent performance and with size and weight reduced to the minimum.



MULTI-STAGE AND MULTI-FUNCTION VACUUM GENERATORS MVG 3 and MVG 7

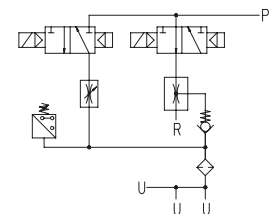
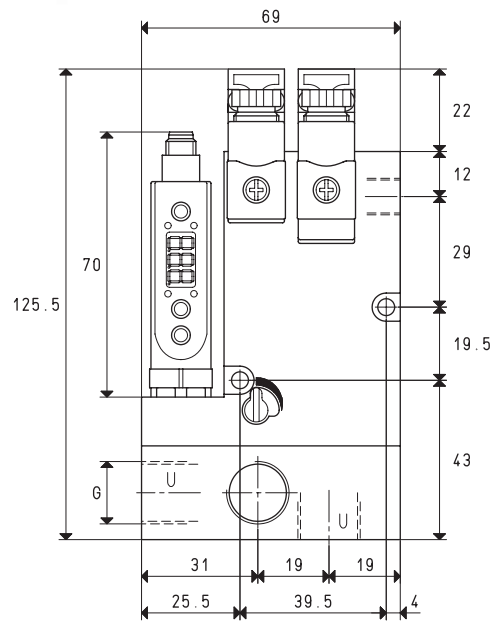
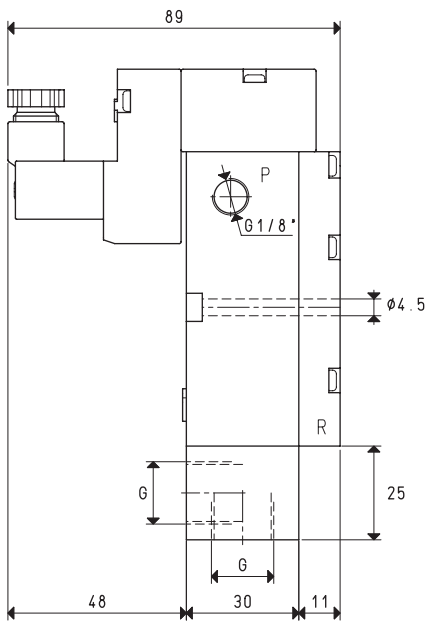

P=COMPRESSED AIR CONNECTION

R=EXHAUST

U=VACUUM CONNECTION

Art.				MVG 3		MVG 7	
Quantity of sucked air	cum/h	2.8	3.0	3.2	5.6	6.0	6.6
Max. vacuum level	-KPa	50	70	85	50	70	85
Final pressure	mbar abs.	500	300	150	500	300	150
Supply pressure	bar (g)	3	4	5	3	4	5
Air consumption	l/s	0.5	0.6	0.8	0.8	1.0	1.3
Max. quantity of blown air at 5 bar	l/min			205			205
Supply solenoid valve position	NO/NC			NO			NO
Ejection solenoid valve position	NC			NC			NC
Supply voltage	V			24 DC			24 DC
Electric absorption	W			2 x 2			2 x 2
Vacuum switch output				PNP			PNP
Class of protection	IP			65			65
Working temperature	°C			-10 / +60			-10 / +60
Noise level	dB(A)			66			70
Weight	Kg			0.666			0.670
G	Ø			G1/4"			G3/8"

Note: To order the generator: with supply solenoid valve NC, please indicate the code MVG .. NC;
without the digital vacuum switch, please indicate the code MVG .. SV;
without the ejection solenoid valve, please indicate the code MVG .. SC.

Note: All the vacuum data indicated in the table are valid at the normal atmospheric pressure of 1013 mbar and are obtained with a constant supply pressure.

Conversion ratio: inch = $\frac{\text{mm}}{25.4}$; pounds = $\frac{\text{g}}{453.6}$ = $\frac{\text{Kg}}{0.4536}$

GAS-NPT thread adapters available at page 1.117

MULTI-FUNCTION VACUUM GENERATORS MVG 3 and MGV 7

Air capacity (NI/s) at different vacuum levels (-KPa)

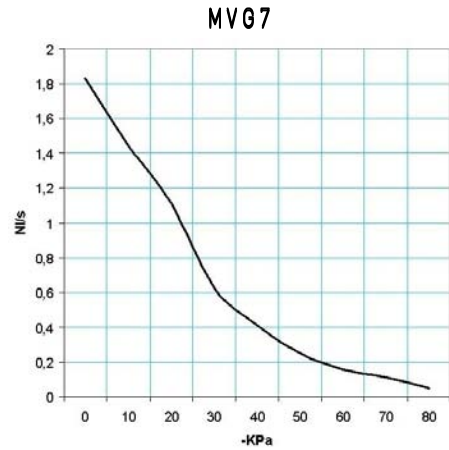
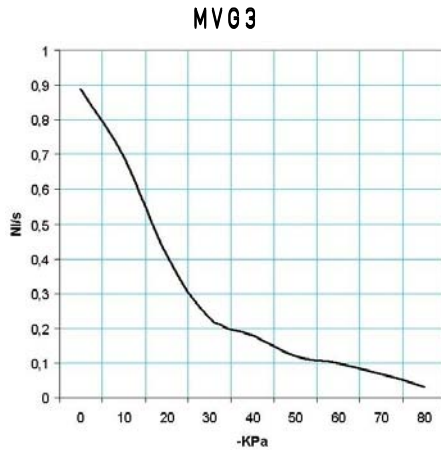

Generator art.	Supply press. bar (g)	Air consumption NI/s	Air capacity (NI/s) at different vacuum levels (-KPa)										Max. vacuum level -KPa
			0	10	20	30	40	50	60	70	80		
MVG 3	5.0	0.8	0.89	0.69	0.41	0.23	0.18	0.12	0.10	0.07	0.03	85	
MVG 7	5.0	1.3	1.72	1.44	1.11	0.63	0.41	0.25	0.16	0.11	0.05	85	

Evacuation time (ms/l = s/m³) at different vacuum levels (-KPa)

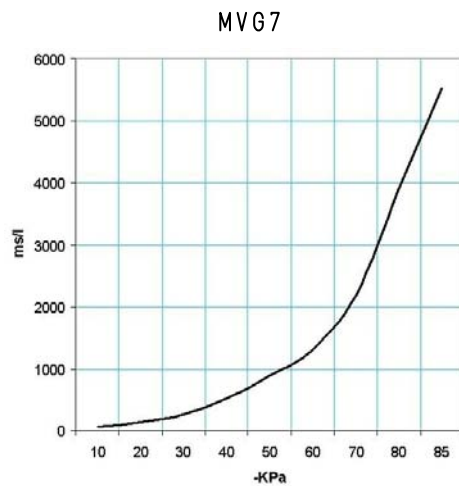
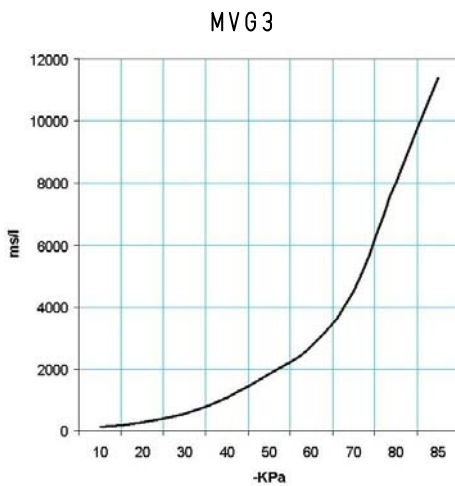

Generator art.	Supply press. bar (g)	Air consumption NI/s	Evacuation time (ms/l = s/m ³) at different vacuum levels (-KPa)										Max. vacuum level -KPa
			10	20	30	40	50	60	70	80	85		
MVG 3	5.0	0.8	119	274	552	1088	1845	2694	4499	8009	11373	85	
MVG 7	5.0	1.3	58	133	268	529	897	1310	2188	3895	5531	85	

ACCESSORIES AND SPARE PARTS UPON REQUEST

Art.	MVG 3	MVG 7
Sealing kit and reed valve	art. 00 KIT MVG 3	00 KIT MVG 7
Electric connection cable with axial connector for vacuum switch		00 12 20
Electric connection cable with radial connector for vacuum switch		00 12 21
Electric connection cable set with built-in energy		
Saving device NO and connectors		00 15 202
Electric connection cable set with built-in energy		
Saving device NC and connectors		00 15 203
Digital vacuum switch		12 10 10
Supply solenoid valve NO		00 15 155
Supply solenoid valve NC		00 15 156

3D drawings available at www.vuototecnica.net

MULTI-STAGE AND MULTI-FUNCTION VACUUM GENERATORS MVG 10 and MVG 14

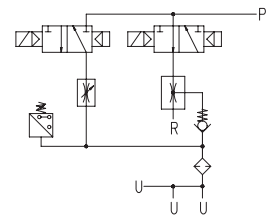
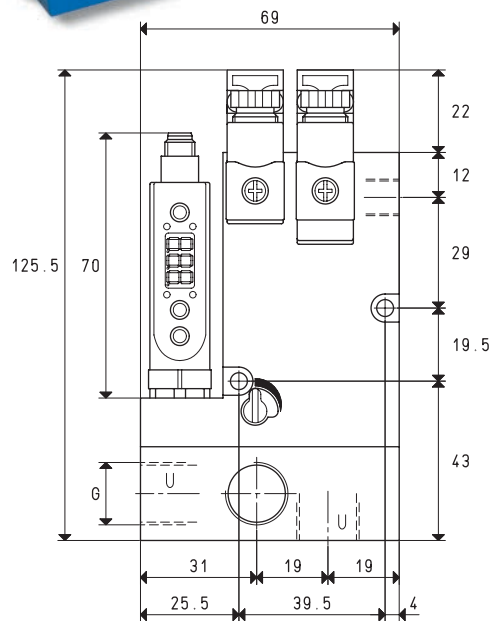
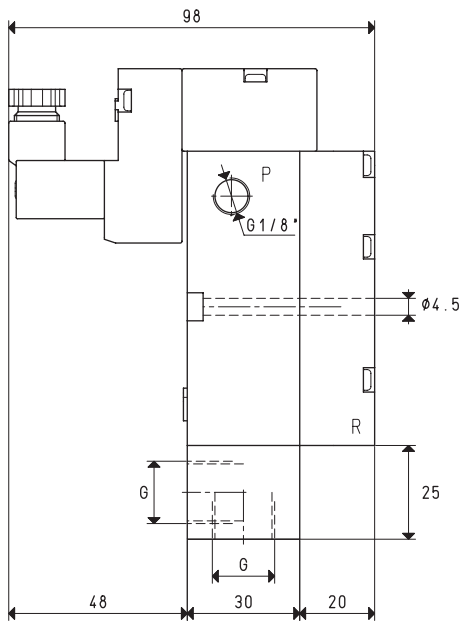

P=COMPRESSED AIR CONNECTION

R=EXHAUST

U=VACUUM CONNECTION

Art.				MVG 10		MVG 14	
Quantity of sucked air	cum/h	7.7	8.4	9.2	10.2	11.2	12.2
Max. vacuum level	-KPa	50	70	85	50	70	85
Final pressure	mbar abs.	500	300	150	500	300	150
Supply pressure	bar (g)	3	4	5	3	4	5
Air consumption	l/s	0.9	1.3	1.7	1.3	1.7	2.1
Max. quantity of blown air at 5 bar (g)	l/min			205		205	
Supply solenoid valve position	NO/NC			NO		NO	
Ejection solenoid valve position	NC			NC		NC	
Supply voltage	V			24 DC		24 DC	
Electric absorption	W			1.4 x 2		1.4 x 2	
Vacuum switch output				PNP		PNP	
Class of protection	IP			65		65	
Working temperature	°C			-10 / +60		-10 / +60	
Noise level	dB(A)			62		70	
Weight	Kg			0.716		0.720	
G	Ø			G3/8"		G3/8"	

Note: To order the generator: with supply solenoid valve NC, please indicate the code MVG .. NC;
without the digital vacuum switch, please indicate the code MVG .. SV;
without the ejection solenoid valve, please indicate the code MVG .. SC.

Note: All the vacuum data indicated in the table are valid at the normal atmospheric pressure of 1013 mbar and are obtained with a constant supply pressure.

Conversion ratio: inch = $\frac{\text{mm}}{25.4}$; pounds = $\frac{\text{g}}{453.6}$ = $\frac{\text{Kg}}{0.4536}$

GAS-NPT thread adapters available at page 1.117

MULTI-FUNCTION VACUUM GENERATORS MVG 10 and MVG 14

Air capacity (NI/s) at different vacuum levels (-Kpa)

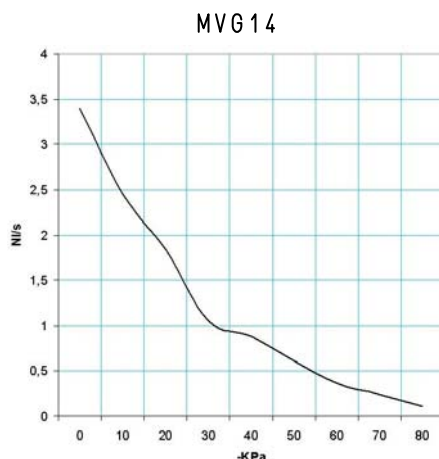
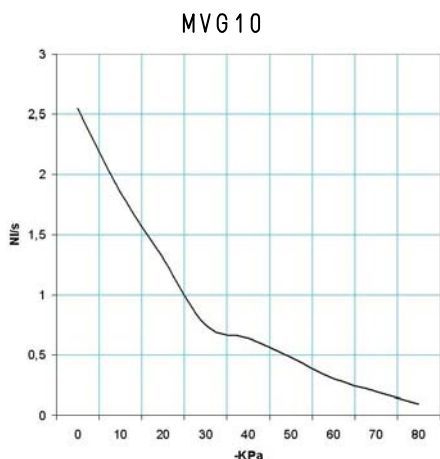

Generator art.	Supply press. bar (g)	Air consumption NI/s	Air capacity (NI/s) at different vacuum levels (-KPa)										Max. vacuum level -KPa
			0	10	20	30	40	50	60	70	80		
MVG 10	5.0	1.7	2.55	1.85	1.30	0.75	0.64	0.48	0.30	0.20	0.09	85	
MVG 14	5.0	2.1	3.40	2.45	1.84	1.05	0.88	0.61	0.36	0.24	0.11	85	

Evacuation time (ms/l=s/m³) at different vacuum levels (-Kpa)

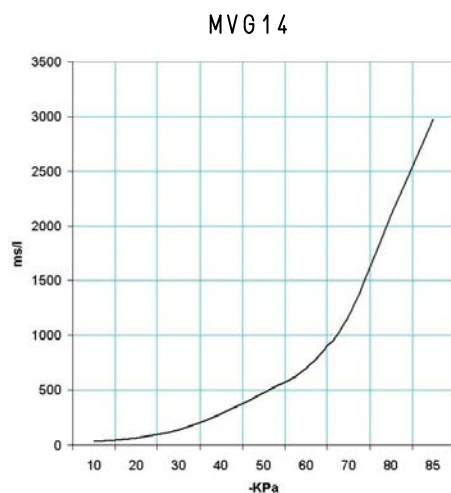
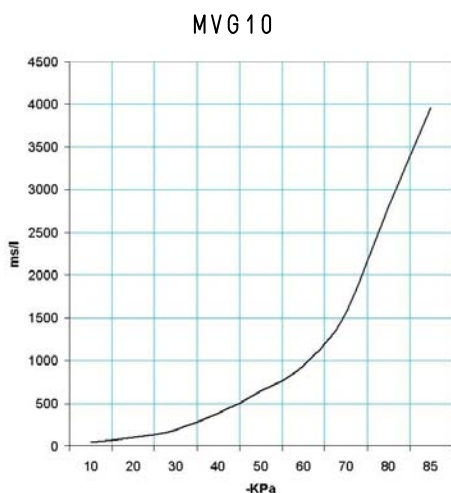

Generator art.	Supply press. bar (g)	Air consumption NI/s	Evacuation time (ms/l = s/m ³) at different vacuum levels (-KPa)								Max. vacuum level -KPa	
			10	20	30	40	50	60	70	80		85
MVG 10	5.0	1.7	41	95	192	379	642	938	1567	2790	3962	85
MVG 14	5.0	2.1	31	71	144	284	482	704	1175	2092	2971	85

ACCESSORIES AND SPARE PARTS UPON REQUEST

Art.	MVG 10	MVG 14
Sealing kit and reed valve	art. 00 KIT MVG 10	art. 00 KIT MVG 14
Electric connection cable with axial connector for vacuum switch		art. 00 12 20
Electric connection cable with radial connector for vacuum switch		art. 00 12 21
Electric connection cable set with built-in energy		
Saving device NO and connectors		art. 00 15 202
Electric connection cable set with built-in energy		
Saving device NC and connectors		art. 00 15 203
Digital vacuum switch		art. 12 10 10
Supply solenoid valve NO		art. 00 15 155
Supply solenoid valve NC		art. 00 15 156

ACCESSORIES AND SPARE PARTS FOR MULTI-STAGE AND MULTI-FUNCTION VACUUM GENERATORS SERIES MVG

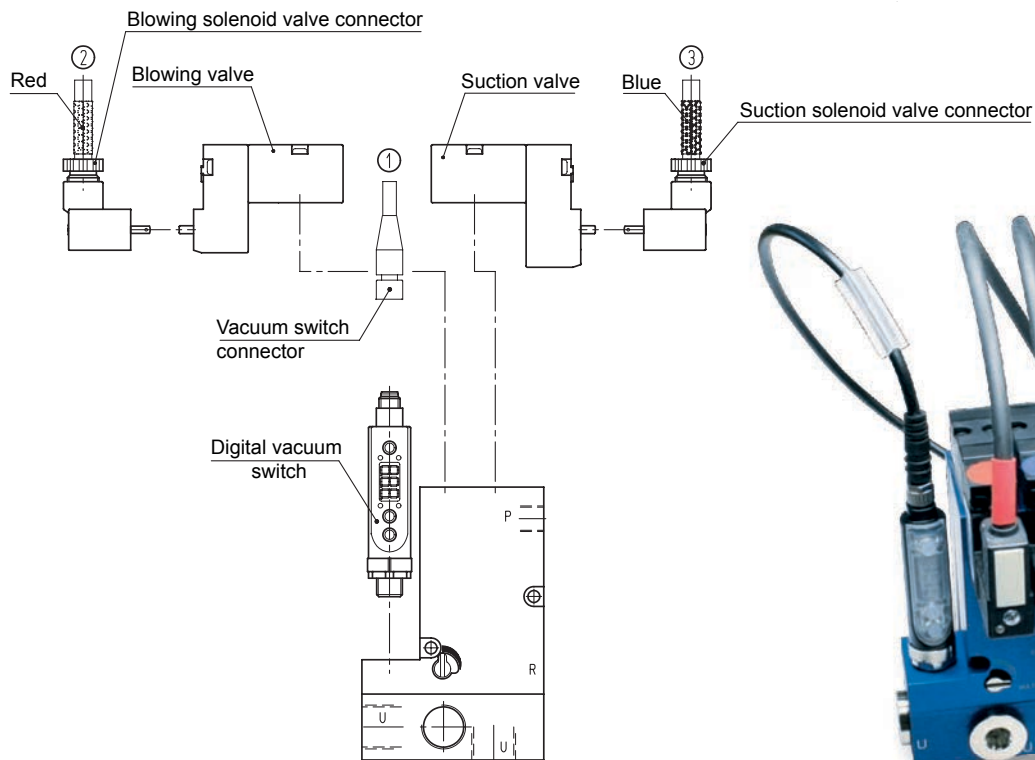
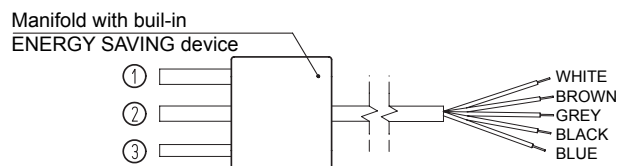

Cable set with built-in energy saving device

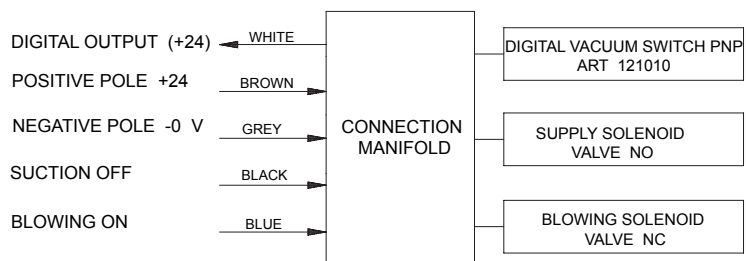

Art.	Description
00 15 202	<p>Cable set with built-in energy saving device for connection to:</p> <ul style="list-style-type: none"> - Digital vacuum switch - Supply solenoid valve NO - Ejection solenoid valve NC <p>Cable length = 5 mt.</p>

ACCESSORIES AND SPARE PARTS FOR MULTI-STAGE AND MULTI-FUNCTION VACUUM GENERATORS SERIES MVG

Cable set with built-in energy saving device

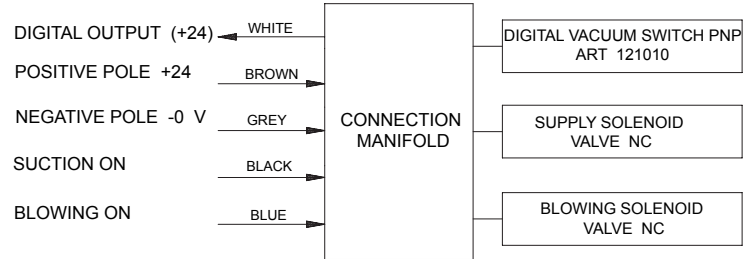

Art.	Description
00 15 203	Cable set with built-in energy saving device for connection to: - Digital vacuum switch - Supply solenoid valve NC - Ejection solenoid valve NC Cable length= 5 mt.

Connector



Art.	Description
00 15 157	Connector with LED for micro solenoid valve

Cable with axial connector



Art.	Description
00 12 20	Electric connection cable with axial connector for digital vacuum switch

Cable with radial connector



Art.	Description
00 12 21	Electric connection cable with radial connector for digital vacuum switch

ACCESSORIES AND SPARE PARTS FOR MULTI-STAGE AND MULTI-FUNCTION VACUUM GENERATORS SERIES MVG

Supply solenoid valve NO

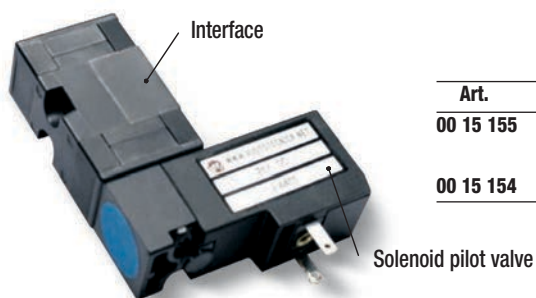

Art.	Description
00 15 155	NO solenoid pilot valve with built-in low-absorption electric coil
00 15 154	Interface

Supply solenoid valve NC

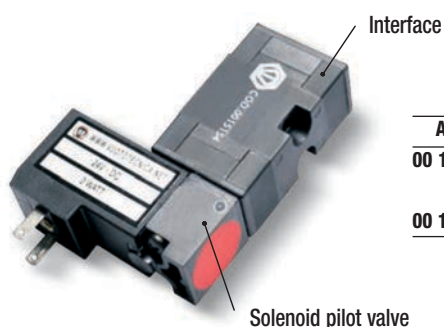

Art.	Description
00 15 156	NC solenoid pilot valve with built-in low-absorption electric coil
00 15 154	Interface

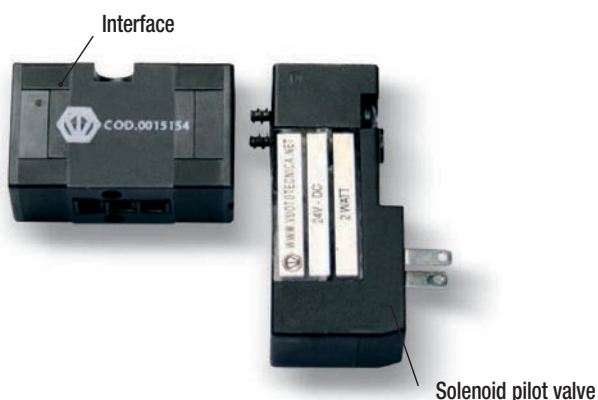

Ejection solenoid valve spare plate



Art.	Description
00 15 178	Ejection solenoid valve spare plate

Digital vacuum switch



Art.	Description
12 10 10	Digital vacuum switch

MODULAR MULTI-STAGE AND MULTI-FUNCTION VACUUM GENERATORS SERIES GVMM

Modular multi-function vacuum generators are true independent vacuum units that offer an entire vacuum control system.

They feature a reduced thickness and weight compared to their suction capacity and they have been designed to be assembled with screws to one or more intermediate modules MI. The original internal connection system for the compressed air supply allows communication with no need for external manifolds.

This modular system allows increasing the number of independent vacuum units according to the requirements. In fact, you can order a multi-function vacuum generator and the intermediate modules with the desired capacities, already assembled, or you can assemble one or more intermediate modules to the GVMM generator that has already been installed on the machine, without having to make particular modifications. GVMM vacuum generators are composed of an anodised aluminium monobloc with lid, inside of which the silenced multiple ejectors are installed and the vacuum chamber and the compressed air supply connection are contained.

The following items are assembled externally:

- A micro solenoid valve for supplying compressed air to the generator.
- A micro solenoid valve for blowing the exhaust compressed air.
- An adjustable flow regulator for dosing the exhaust air.
- A digital vacuum switch with display and commutation LEDs for managing the compressed air supply and for signalling the safety cycle start-up.
- An anodised aluminium or transparent plexiglas manifold provided with vacuum connections with built-in suction filtre, easy to inspect, and a check valve for maintaining the vacuum in case of electricity or compressed air failure.

By activating the compressed air solenoid valve, the generator creates vacuum at the service. Once the preset maximum value is reached, the vacuum switch acts on the solenoid valve electric coil and interrupts the air supply, restoring it when the vacuum value returns below the minimum value.

Along with maintaining the vacuum level within preset safety values (hysteresis), this modulation allows saving a considerable amount of compressed air.

A second vacuum switch signal, also adjustable and independent from the first, can be used to start up the cycle when the vacuum level is suitable for the application. Once the working cycle is completed, the compressed air supply is deactivated and, at the same time, the ejection micro solenoid valve is activated for a quick restoration of the atmospheric pressure at the application.

GVMM multi-function vacuum generators can be installed in any position and are suited for interconnecting vacuum gripping systems for handling sheet steel, glass, marble, ceramic, plastic, cardboard, wood, etc., and, in particular, for the industrial robotics sector which requires equipment with excellent performance and several independent vacuum units for controlling several applications but with reduced size and weight.



MODULAR MULTI-STAGE AND MULTI-FUNCTION VACUUM GENERATORS GVMM 3 and GVMM 7

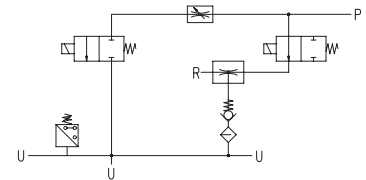
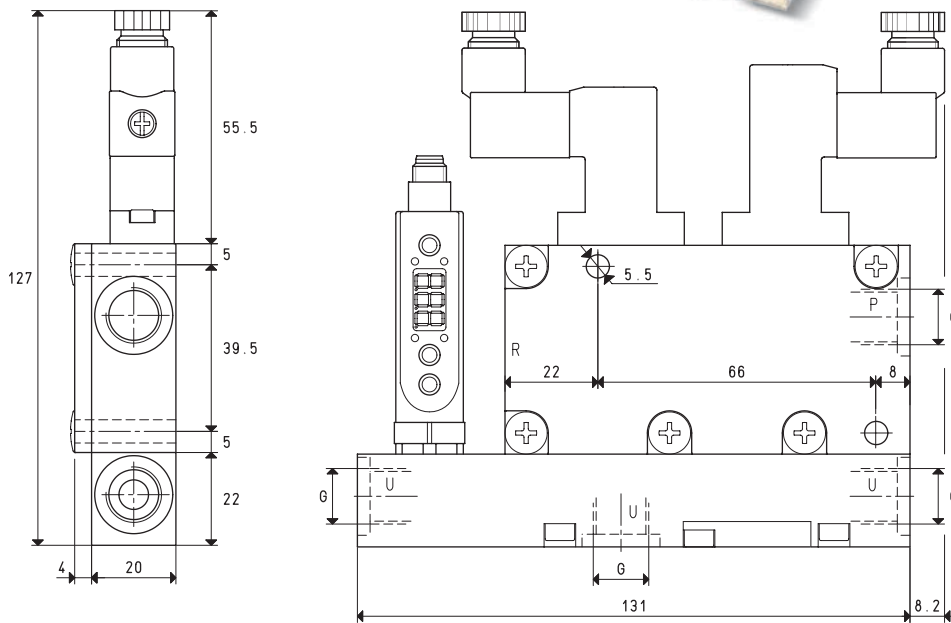

P=COMPRESSED AIR CONNECTION R=EXHAUST U=VACUUM CONNECTION

Art.		GVMM 3			GVMM 7		
Quantity of sucked air	cum/h	2.6	2.8	3.0	5.5	6.0	6.4
Max. vacuum level	-KPa	64	85	85	60	80	85
Final pressure	mbar abs.	360	150	150	400	200	150
Supply pressure	bar (g)	3	4	5	3	4	5
Air consumption	l/s	0.6	0.7	0.8	0.9	1.1	1.3
Max. quantity of blown air at 5 bar (g)	l/min			128			128
Supply solenoid valve position	NO/NC			NO			NO
Electric absorption	W			2			2
Ejection solenoid valve position	NC			NC			NC
Electric absorption	W			4			4
Supply voltage	V			24DC			24DC
Vacuum switch output				PNP			PNP
Class of protection	IP			65			65
Working temperature	°C			-10 / +60			-10 / +60
Noise level	dB(A)			66			70
Weight	g			420			420
G	Ø			G1/4"			G1/4"

Note: To order the generator: with supply solenoid valve NC, please indicate the code GVMM .. NC;
without the digital vacuum switch, please indicate the code GVMM .. SV.

Note: All the vacuum data indicated in the table are valid at the normal atmospheric pressure of 1013 mbar and are obtained with a constant supply pressure.

Conversion ratio: inch = $\frac{mm}{25.4}$; pounds = $\frac{g}{453.6}$ = $\frac{Kg}{0.4536}$

GAS-NPT thread adapters available at page 1.117

3D drawings available at www.vuototecnica.net

MODULAR MULTI-STAGE AND MULTI-FUNCTION VACUUM GENERATORS GVMM 3 and GVMM 7

Air capacity (NI/s) at different vacuum levels (-KPa)

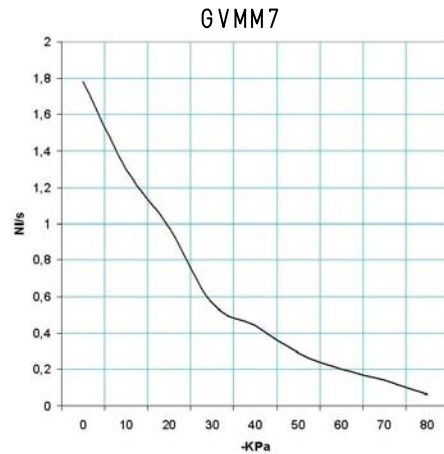
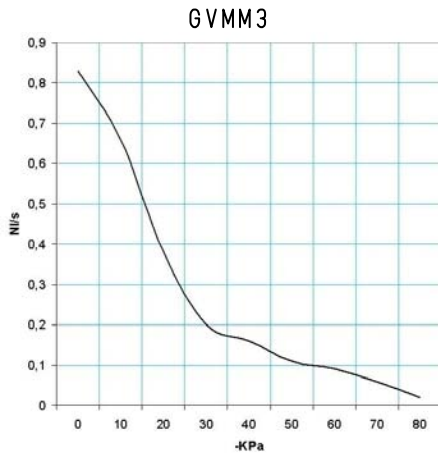

Generator art.	Supply press. bar (g)	Air consumption NI/s	Air capacity (NI/s) at different vacuum levels (-KPa)										Max. vacuum level -KPa
			0	10	20	30	40	50	60	70	80	85	
GVMM 3	5.0	0.8	0.83	0.66	0.38	0.20	0.16	0.11	0.09	0.06	0.02	0.02	85
GVMM 7	5.0	1.3	1.78	1.30	0.98	0.56	0.44	0.29	0.20	0.14	0.06	0.06	85

Evacuation time (ms/l= s/m^3) at different vacuum levels (-KPa)

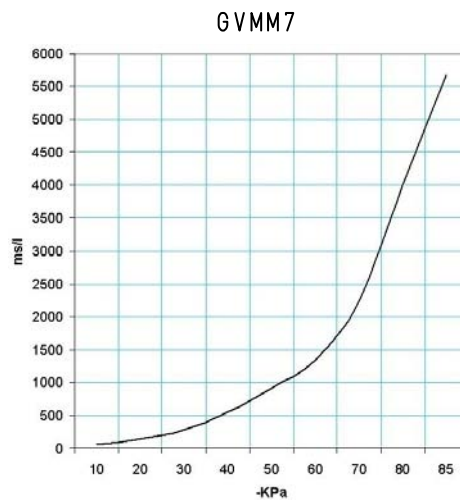
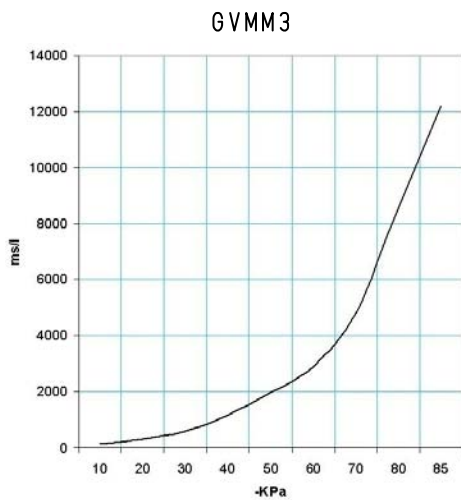

Generator art.	Supply press. bar (g)	Air consumption NI/s	Evacuation time (ms/l = s/m^3) at different vacuum levels (-KPa)										Max. vacuum level -KPa
			10	20	30	40	50	60	70	80	85		
GVMM 3	5.0	0.8	128	294	592	1167	1978	2889	4824	8588	12195	12195	85
GVMM 7	5.0	1.3	59	137	275	543	921	1344	2245	3997	5676	5676	85

ACCESSORIES AND SPARE PARTS UPON REQUEST

Art.		GVMM 3	GVMM 7
Sealing kit and reed valve	art.	00 KIT GVMM 3	00 KIT GVMM 7
Electric connection cable with axial connector for vacuum switch	art.		00 12 20
Electric connection cable with radial connector for vacuum switch	art.		00 12 21
Electric connection cable set with built-in energy			
Saving device NO and connectors	art.		00 15 202
Electric connection cable set with built-in energy			
Saving device NC and connectors	art.		00 15 203
Digital vacuum switch	art.		12 10 10
Supply solenoid valve NO	art.		00 15 176
Supply solenoid valve NC	art.		00 15 175

MODULAR MULTI-STAGE AND MULTI-FUNCTION VACUUM GENERATORS GVMM 10 and GVMM 14

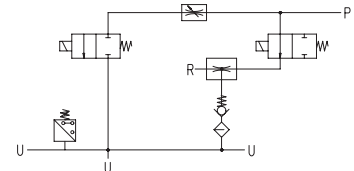
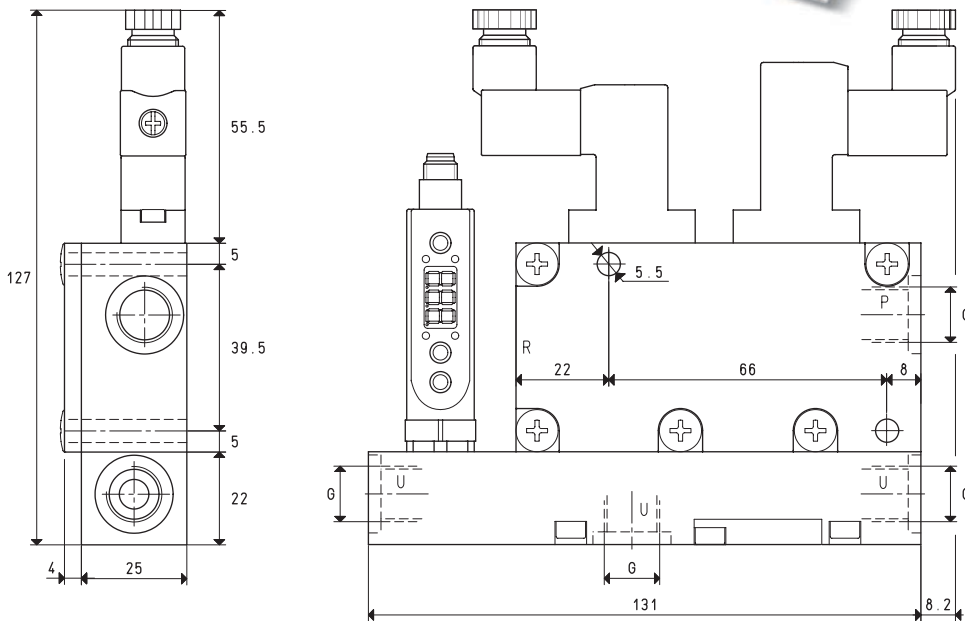
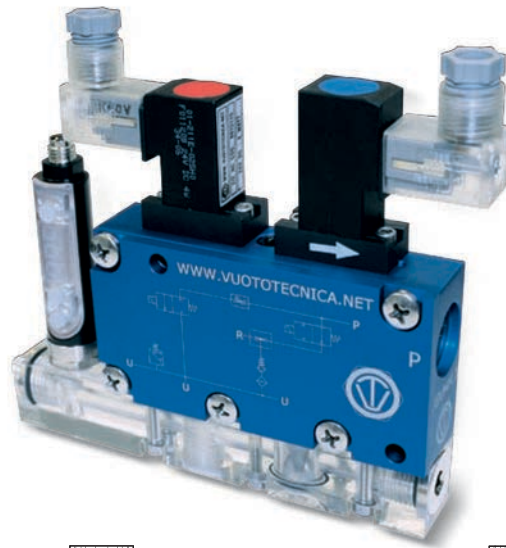

P=COMPRESSED AIR CONNECTION

R=EXHAUST

U=VACUUM CONNECTION

Art.		GVMM 10				GVMM 14	
Quantity of sucked air	cum/h	7.5	8.3	9.1	10.1	11.1	12.1
Max. vacuum level	-KPa	60	80	85	60	80	85
Final pressure	mbar abs.	400	200	150	400	200	150
Supply pressure	bar (g)	3	4	5	3	4	5
Air consumption	NI/s	1.1	1.4	1.7	1.4	1.7	2.1
Max. quantity of blown air at 5 bar (g)	l/min			128			128
Supply solenoid valve position	NO/NC			NO			NO
Electric absorption	W			2			2
Ejection solenoid valve position	NC			NC			NC
Electric absorption	W			4			4
Supply voltage	V			24DC			24DC
Vacuum switch output				PNP			PNP
Class of protection	IP			65			65
Working temperature	°C			-10 / +60			-10 / +60
Noise level	dB(A)			70			72
Weight	g			460			460
G	Ø			G1/4"			G1/4"

Note: To order the generator: with supply solenoid valve NC, please indicate the code GVMM .. NC;
without the digital vacuum switch, please indicate the code GVMM .. SV.

Note: All the vacuum data indicated in the table are valid at the normal atmospheric pressure of 1013 mbar and are obtained with a constant supply pressure.

Conversion ratio: inch = $\frac{\text{mm}}{25.4}$; pounds = $\frac{\text{g}}{453.6} = \frac{\text{Kg}}{0.4536}$

GAS-NPT thread adapters available at page 1.117

MODULAR MULTI-STAGE AND MULTI-FUNCTION VACUUM GENERATORS

GVMM 10 and GVMM 14

Air capacity (NI/s) at different vacuum levels (-Kpa)

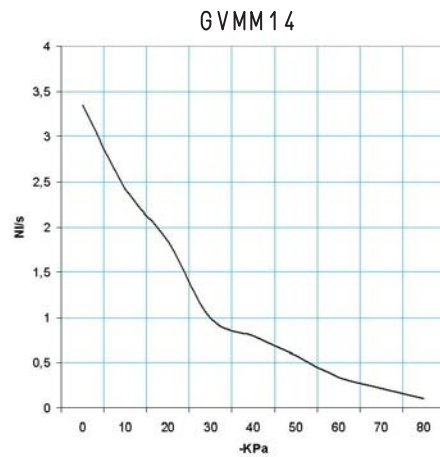
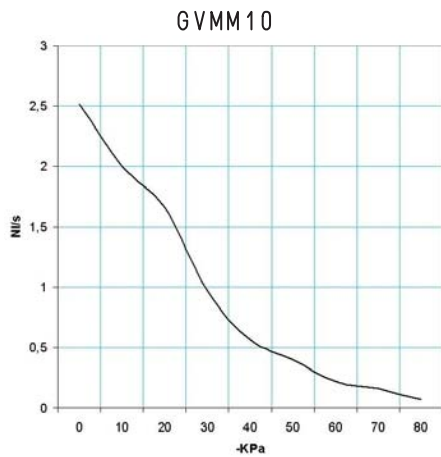

Generator art.	Supply press. bar (g)	Air consumption NI/s	Air capacity (NI/s) at different vacuum levels (-KPa)										Max. vacuum level -KPa
			0	10	20	30	40	50	60	70	80		
GVMM 10	5.0	1.7	2.52	2.00	1.66	0.97	0.56	0.40	0.22	0.16	0.07	85	
GVMM 14	5.0	2.1	3.35	2.42	1.84	0.99	0.80	0.58	0.34	0.22	0.10	85	

Evacuation time (ms/l=s/m³) at different vacuum levels (-Kpa)

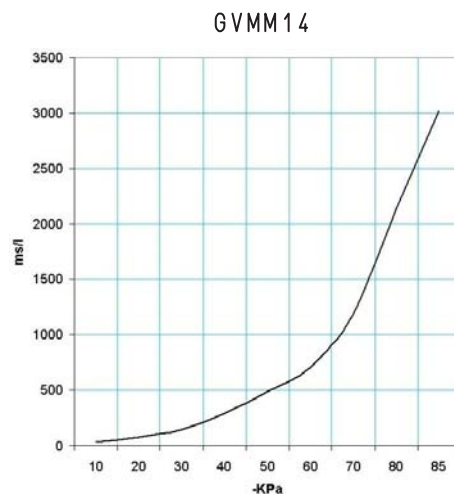
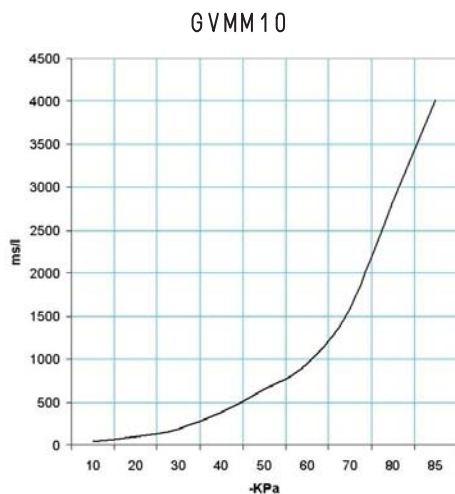

Generator art.	Supply press. bar (g)	Air consumption NI/s	Evacuation time (ms/l = s/m ³) at different vacuum levels (-KPa)										Max. vacuum level -KPa
			10	20	30	40	50	60	70	80	85		
GVMM 10	5.0	1.7	42	97	195	384	651	951	1589	2828	4016	85	
GVMM 14	5.0	2.1	31	72	146	288	489	714	1193	2124	3016	85	

ACCESSORIES AND SPARE PARTS UPON REQUEST

Art.		GVMM 10	GVMM 14
Sealing kit and reed valve	art.	00 KIT GVMM 10	00 KIT GVMM 14
Electric connection cable with axial connector for vacuum switch	art.		00 12 20
Electric connection cable with radial connector for vacuum switch	art.		00 12 21
Electric connection cable set with built-in energy			
Saving device NO and connectors	art.		00 15 202
Electric connection cable set with built-in energy			
Saving device NC and connectors	art.		00 15 203
Digital vacuum switch	art.		12 10 10
Supply solenoid valve NO	art.		00 15 176
Supply solenoid valve NC	art.		00 15 175

MULTI-STAGE, MULTI-FUNCTION AND MODULAR INTERMEDIATE VACUUM MODULES SERIES MI

Intermediate modules are non-independent multi-stage and multi-function vacuum generators to be assembled to the generators of the GVMM range.

Their thickness and weight are reduced to the maximum compared to their suction capacity and they have been designed to be enclosed between the lid and the base of the GVMM vacuum generator and fixed with screws. The internal connections for the compressed air supply allow communication between them and the basic generator, with no need for external manifolds.

This way, each module becomes an independent vacuum unit that can control an entire vacuum system.

They can be ordered in the desired amount and capacity, either already assembled onto the GVMM multi-function vacuum generator, or separately, to be assembled to the GVMM generator previously installed onto the machine. In this case, we suggest ordering a screw kit suitable for the number of modules to be assembled.

MI intermediate vacuum modules are made up of the same elements that compose GVMM generators, except for the lid. They operate and they are used as the GVMM multi-function vacuum generator onto which they are assembled.



INTERMEDIATE VACUUM MODULES MI 3 and MI 7

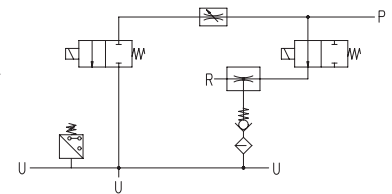
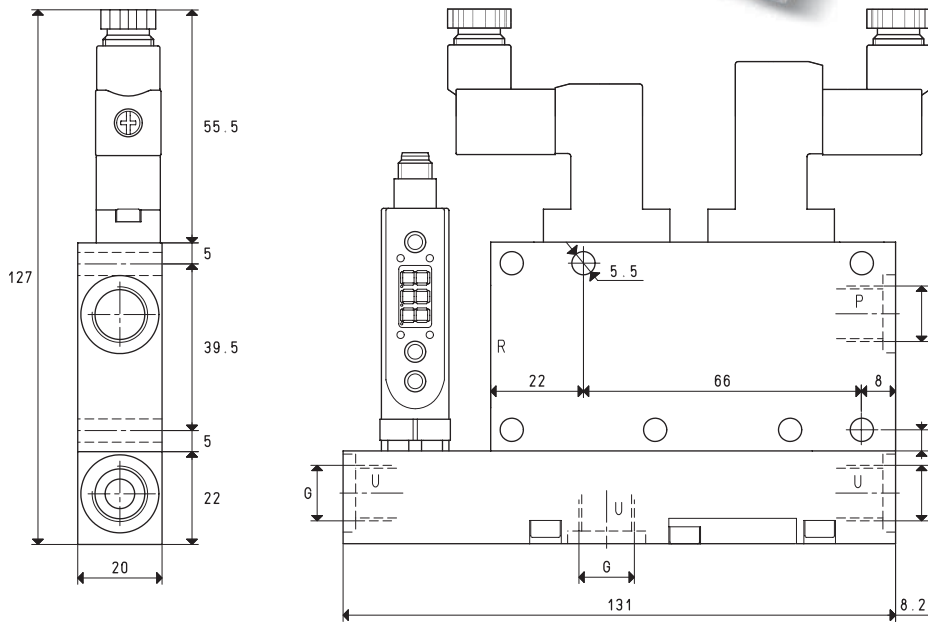
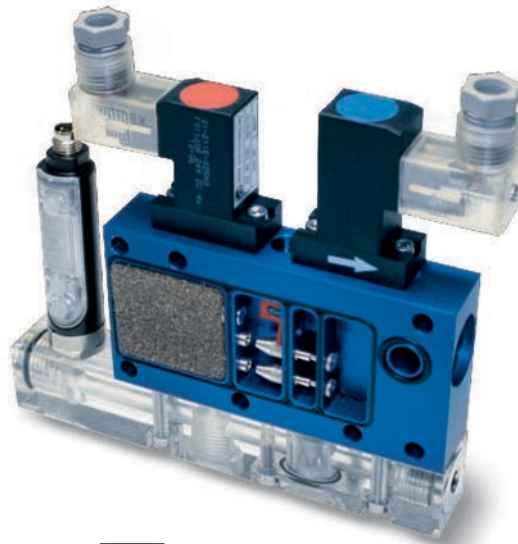

P=COMPRESSED AIR CONNECTION

R=EXHAUST

U=VACUUM CONNECTION

Art.				MI 3			MI 7
Quantity of sucked air	cum/h	2.6	2.8	3.0	5.5	6.0	6.4
Max. vacuum level	-kPa	64	85	85	60	80	85
Final pressure	mbar abs.	360	150	150	400	200	150
Supply pressure	bar (g)	3	4	5	3	4	5
Air consumption	NI/s	0.6	0.7	0.8	0.9	1.1	1.3
Max. quantity of blown air at 5 bar (g)	l/min			128			128
Supply solenoid valve position	NO/NC			NO			NO
Electric absorption	W			2			2
Ejection solenoid valve position	NC			NC			NC
Electric absorption	W			4			4
Supply voltage	V			24DC			24DC
Vacuum switch output				PNP			PNP
Class of protection	IP			65			65
Working temperature	°C			-10 / +60			-10 / +60
Noise level	dB(A)			66			70
Weight	g			380			380
G	Ø			G1/4"			G1/4"

Note: To order the generator: with supply solenoid valve NC, please indicate the code MI .. NC;
without the digital vacuum switch, please indicate the code MI .. SV.

Note: All the vacuum data indicated in the table are valid at the normal atmospheric pressure of 1013 mbar and are obtained with a constant supply pressure.

3D drawings available at www.vuototecnica.net

Air capacity (NI/s) at different vacuum levels (-Kpa)

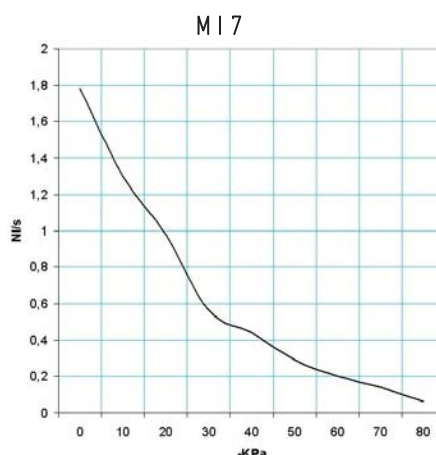
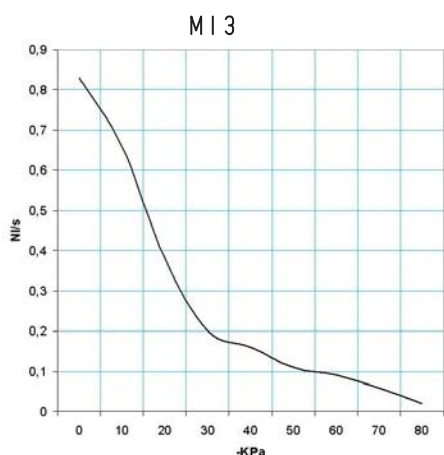

Generator art.	Supply press. bar (g)	Air consumption NI/s	Air capacity (NI/s) at different vacuum levels (-KPa)										Max. vacuum level -KPa
			0	10	20	30	40	50	60	70	80		
MI 3	5.0	0.8	0.83	0.66	0.38	0.20	0.16	0.11	0.09	0.06	0.02	85	
MI 7	5.0	1.3	1.78	1.30	0.98	0.56	0.44	0.29	0.20	0.14	0.06	85	

Evacuation time (ms/l=s/m³) at different vacuum levels (-Kpa)

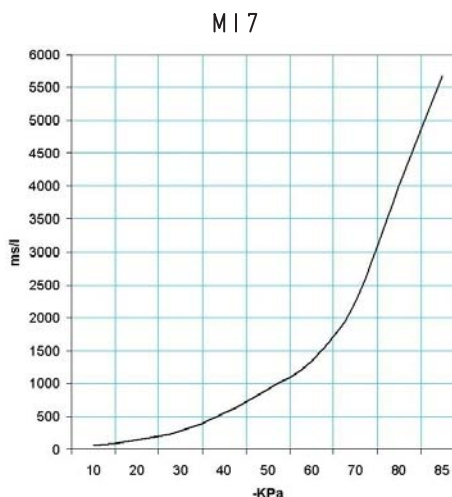
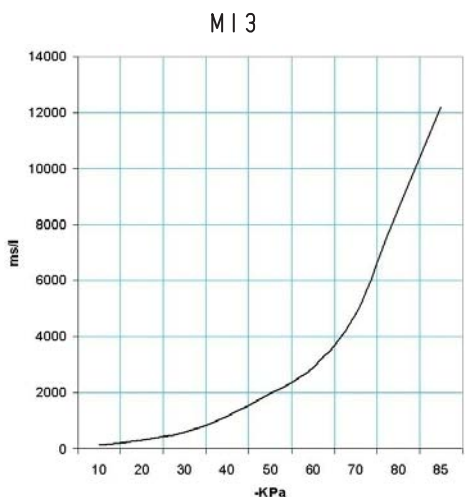

Generator art.	Supply press. bar (g)	Air consumption NI/s	Evacuation time (ms/l = s/m ³) at different vacuum levels (-KPa)										Max. vacuum level -KPa
			10	20	30	40	50	60	70	80	85		
MI 3	5.0	0.8	128	294	592	1167	1978	2889	4824	8588	12195	85	
MI 7	5.0	1.3	59	137	275	543	921	1344	2245	3997	5676	85	

ACCESSORIES AND SPARE PARTS UPON REQUEST

Art.	MI 3	MI 7
Sealing kit and reed valve	art. 00 KIT MI 3	art. 00 KIT MI 7
Electric connection cable with axial connector for vacuum switch		00 12 20
Electric connection cable with radial connector for vacuum switch		00 12 21
Electric connection cable set with built-in energy		00 15 202
Saving device NO and connectors		00 15 203
Electric connection cable set with built-in energy		12 10 10
Saving device NC and connectors		00 15 176
Digital vacuum switch		00 15 175
Supply solenoid valve NO		
Supply solenoid valve NC		

INTERMEDIATE VACUUM MODULES MI 10 and MI 14

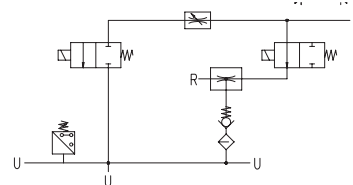
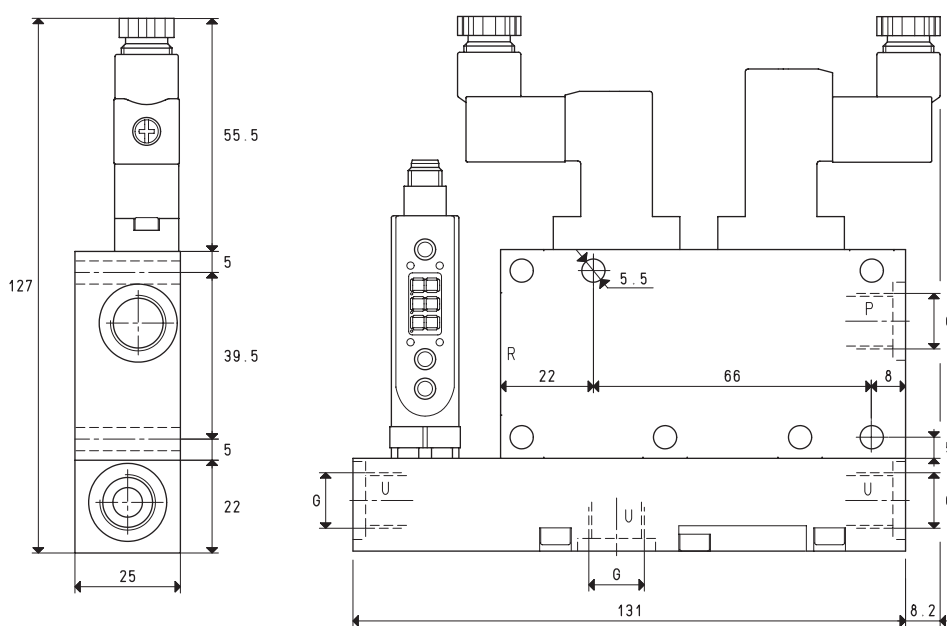
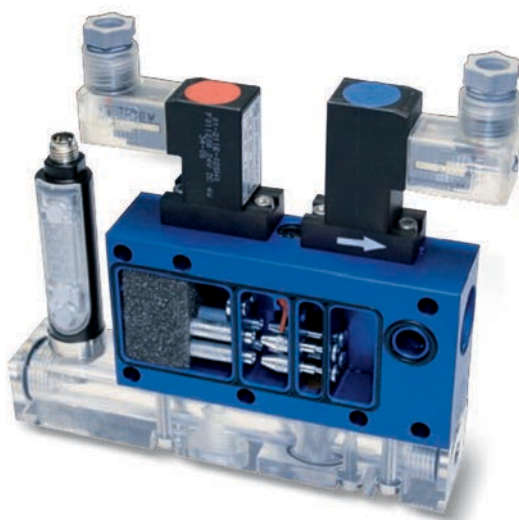

P=COMPRESSED AIR CONNECTION

R=EXHAUST

U=VACUUM CONNECTION

Art.				MI 10			MI 14
Quantity of sucked air	cum/h	7.5	8.3	9.1	10.1	11.1	12.1
Max. vacuum level	-KPa	60	80	85	60	80	85
Final pressure	mbar abs.	400	200	150	400	200	150
Supply pressure	bar (g)	3	4	5	3	4	5
Air consumption	NI/s	1.1	1.4	1.7	1.4	1.7	2.1
Max. quantity of blown air at 5 bar (g)	l/min			128			128
Supply solenoid valve position	NO/NC			NO			NO
Electric absorption	W			2			2
Ejection solenoid valve position	NC			NC			NC
Electric absorption	W			4			4
Supply voltage	V			24DC			24DC
Vacuum switch output				PNP			PNP
Class of protection	IP			65			65
Working temperature	°C			-10 / +60			-10 / +60
Noise level	dB(A)			70			72
Weight	g			410			410
G	Ø			G1/4"			G1/4"

Note: To order the generator: with supply solenoid valve NC, please indicate the code MI .. NC;
without the digital vacuum switch, please indicate the code MI .. SV.

Note: All the vacuum data indicated in the table are valid at the normal atmospheric pressure of 1013 mbar and are obtained with a constant supply pressure.

Air capacity (NI/s) at different vacuum levels (-Kpa)

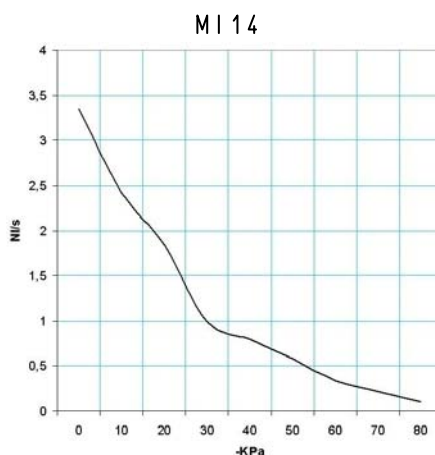
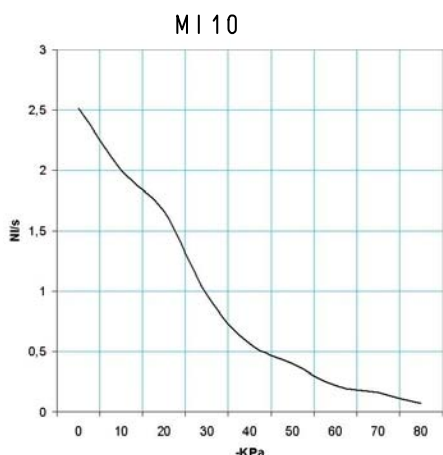

Generator art.	Supply press. bar (g)	Air consumption NI/s	Air capacity (NI/s) at different vacuum levels (-KPa)										Max. vacuum level -KPa
			0	10	20	30	40	50	60	70	80		
MI 10	5.0	1.7	2.52	2.00	1.66	0.97	0.56	0.40	0.22	0.16	0.07	85	
MI 14	5.0	2.1	3.35	2.42	1.84	0.99	0.80	0.58	0.34	0.22	0.10	85	

Evacuation time (ms/l=s/m³) at different vacuum levels (-Kpa)

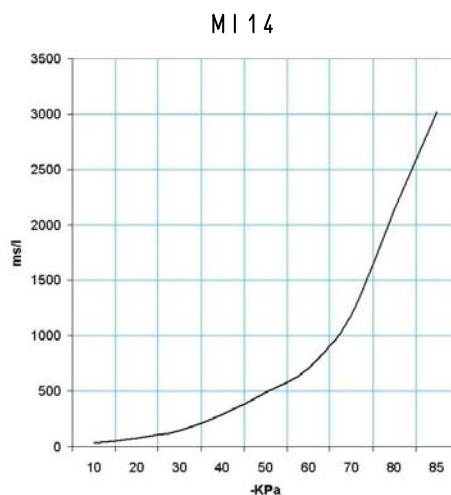
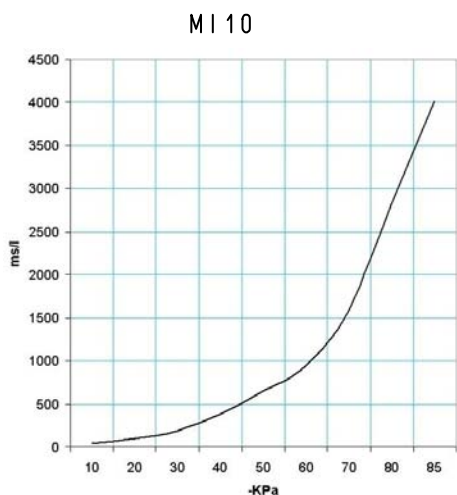

Generator art.	Supply press. bar (g)	Air consumption NI/s	Evacuation time (ms/l = s/m ³) at different vacuum levels (-KPa)										Max. vacuum level -KPa
			10	20	30	40	50	60	70	80	85		
MI 10	5.0	1.7	42	97	195	384	651	951	1589	2828	4016	85	
MI 14	5.0	2.1	31	72	146	288	489	714	1193	2124	3016	85	

ACCESSORIES AND SPARE PARTS UPON REQUEST

Art.	MI 10	MI 14
Sealing kit and reed valve	art. 00 KIT MI 10	art. 00 KIT MI 14
Electric connection cable with axial connector for vacuum switch	art.	00 12 20
Electric connection cable with radial connector for vacuum switch	art.	00 12 21
Electric connection cable set with built-in energy		
Saving device NO and connectors	art.	00 15 202
Electric connection cable set with built-in energy		
Saving device NC and connectors	art.	00 15 203
Digital vacuum switch	art.	12 10 10
Supply solenoid valve NO	art.	00 15 176
Supply solenoid valve NC	art.	00 15 175

3D drawings available at www.vuototecnica.net

ACCESSORIES AND SPARE PARTS FOR VACUUM GENERATORS AND MODULES SERIES GVMM and MI

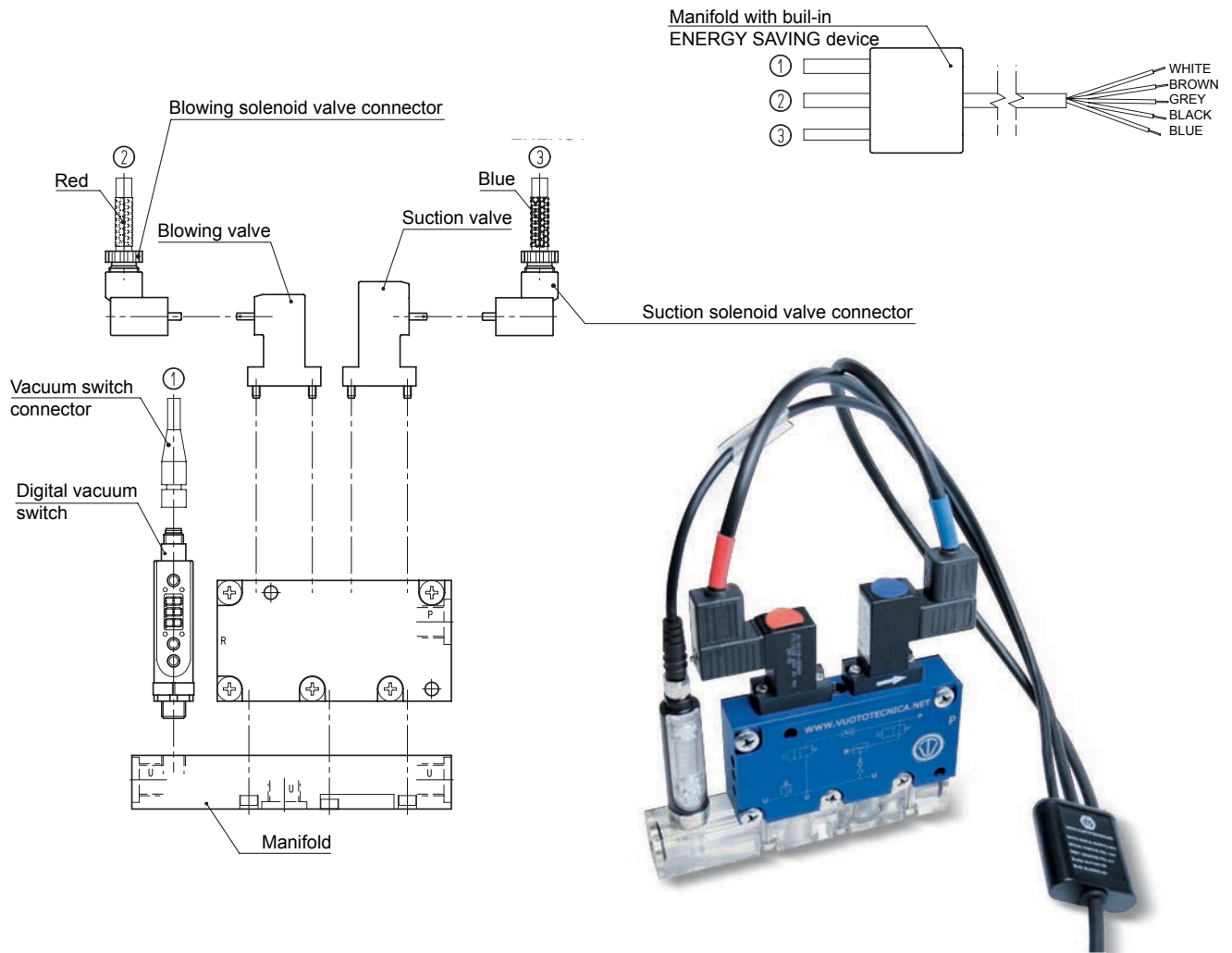

Cable set with built-in energy saving device

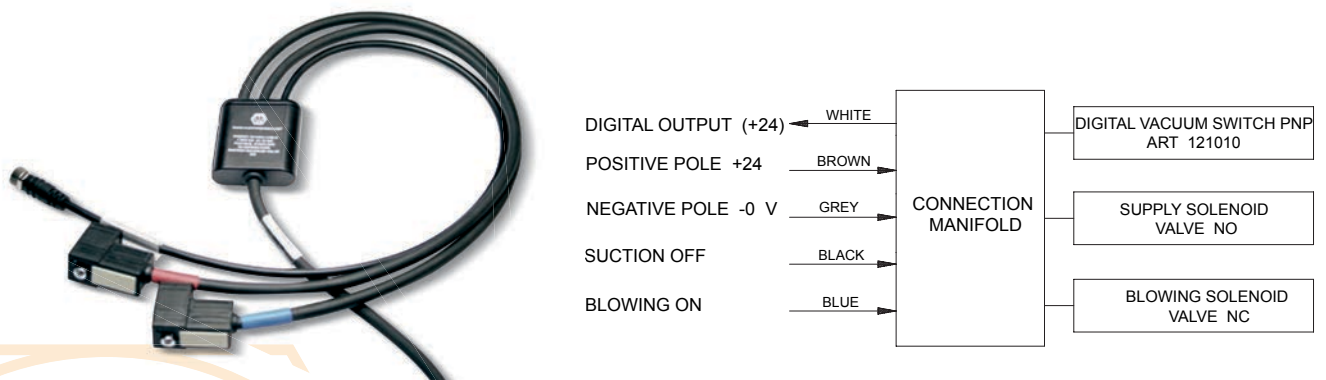

Art.	Description
00 15 202	Cable set with built-in energy saving device for connection to : - Digital vacuum switch - Supply solenoid valve NO - Ejection solenoid valve NC Cable length = 5 mt.

Cable set with built-in energy saving device

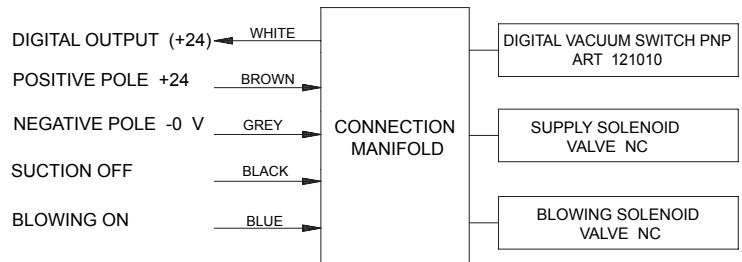

Art.	Description
00 15 203	Cable set with built-in energy saving device for connection to : - Digital vacuum switch - Supply solenoid valve NC - Ejection solenoid valve NC Cable length= 5 mt.

Connector



Art.	Description
00 15 157	Connector with LED for micro solenoid valve

Cable with axial connector



Art.	Description
00 12 20	Electric connection cable with axial connector, for digital vacuum switch

Cable with radial connector



Art.	Description
00 12 21	Electric connection cable with radial connector, for digital vacuum switch

Digital vacuum switch



Art.	Description
12 10 10	Digital vacuum switch

ACCESSORIES AND SPARE PARTS FOR VACUUM GENERATORS AND MODULES SERIES GVMM e MI

Micro solenoid valve NO



Art.	Description
00 15 176	Supply solenoid valve NO

Micro solenoid valve NC

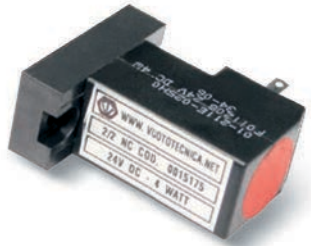

Art.	Description
00 15 175	Supply solenoid valve NC

Plexiglass manifolds

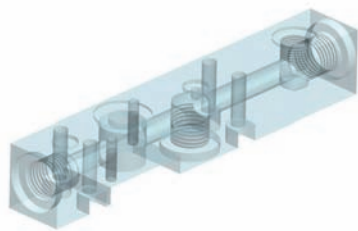

Art.	Description
00 15 171	Plexiglass manifold for GVMM - MI 3/7
00 15 188	Plexiglass manifold for GVMM - MI 10/14

Aluminium manifolds



Art.	Description
00 15 174	Aluminium manifold for GVMM - MI 3/7
00 15 187	Aluminium manifold for GVMM - MI 10/14

Support

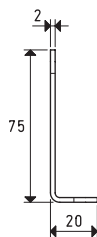
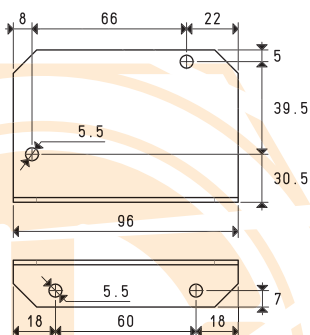

Art.	Description
00 15 306	Galvanised sheet metal L-type fixing support

3D drawings available at www.vuototecnica.net

MODULAR VACUUM SYSTEMS SET-UP

GVMM multi-function vacuum generators can be assembled with one or more intermediate modules, thus forming a modular vacuum system, featuring a compact shape and reduced size and weight.

As a standard, up to 6 vacuum units can be assembled, but using threaded bars instead allows assembling even more.

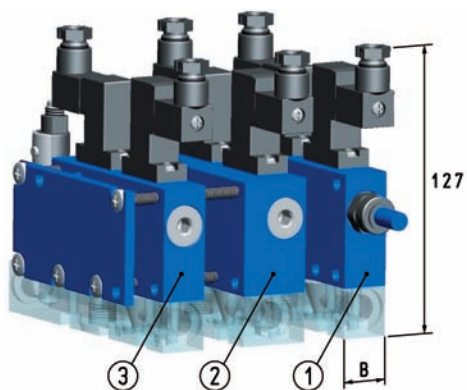

SET-UP EXAMPLE 1

N°	Art.	B
1	GVMM 3 - 7	20
2	MI 10 - 14	25
3	MI 3 - 7	20

Total length L= 65

Recommended screw kit: Art. 00 KIT GVMM 02

Order example:

n°1 Generator GVMM 3

n°1 Intermediate module MI 10

n°1 Intermediate module MI 3

n°1 stainless steel screw kit 00 KIT GVMM 02

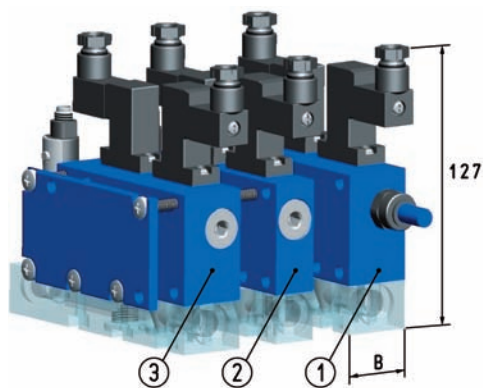
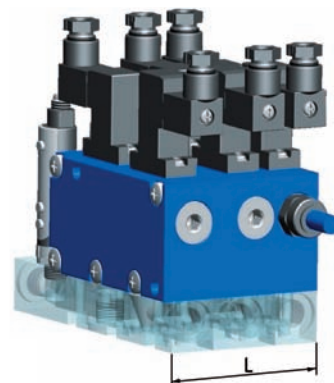

SET-UP EXAMPLE 2

N°	Art.	B
1	GVMM 10 - 14	25
2	MI 3 - 7	20
3	MI 10 - 14	25

Total length L= 70

Recommended screw kit: Art. 00 KIT GVMM 03

Order example:

n°1 Generator GVMM 10

n°1 Intermediate module MI 3

n°1 Intermediate module MI 10

n°1 stainless steel screw kit 00 KIT GVMM 03

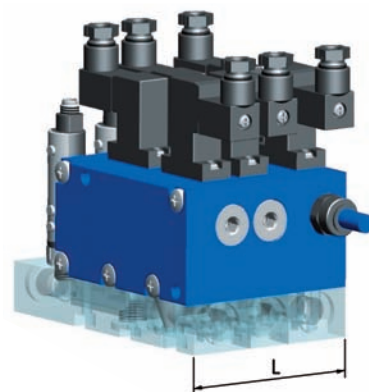

STAINLESS STEEL M5 SCREW KIT

Art.	L
00 KIT GVMM 01	45 - 50
00 KIT GVMM 02	60 - 65
00 KIT GVMM 03	70 - 75
00 KIT GVMM 04	80 - 85
00 KIT GVMM 05	90 - 95
00 KIT GVMM 06	100 - 105
00 KIT GVMM 07	110 - 115
00 KIT GVMM 08	120 - 125
00 KIT GVMM 09	130 - 135
00 KIT GVMM 10	140 - 145
00 KIT GVMM 11	150 - 155

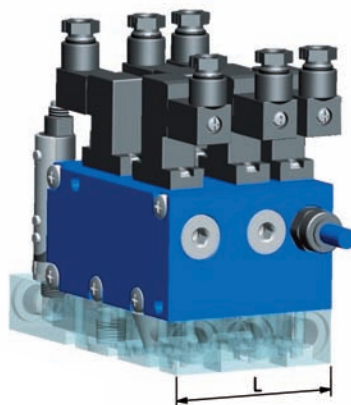

SINGLE-STAGE AND MULTI-FUNCTION VACUUM GENERATORS SERIES AVG

These generators are independent vacuum units that can control an entire vacuum gripping system. They have been specially designed for the AUTOMOTIVE sector and they are equipped with single ejectors that, given the same capacity as the multi-ejector generators, allow a quicker grip and, as a result, a greater compressed air consumption. As a standard, they are provided with a built-in pneumatic energy-saving device.

They are composed of an anodised aluminium monobloc structure, inside of which are installed the ejectors, the servo-controlled slide valve for the compressed air supply and are contained the vacuum chambers as well as the various connections.

On the outside, on the other hand, are installed:

- *A bistable impulse solenoid valve for controlling the slide valve.*
- *A micro solenoid valve for blowing the exhaust compressed air.*
- *A flow regulator for dosing the exhaust compressed air.*
- *Two silencers for removing noise from the ejected air.*
- *An aluminium manifold provided with vacuum connections with built-in:
 - ° *A pneumatic vacuum switch for managing the compressed air supply according to the set vacuum level (energy saving).*
 - ° *A check valve for maintaining the vacuum in case of electricity or compressed air failure.*
 - ° *A suction filtre, easy to inspect through the transparent polycarbonate lid.**

By providing an electric impulse to the two-position micro solenoid valve, the compressed air supply slide valve will be activated and vacuum will be created at the application.

Once the preset maximum value has been reached, the pneumatic vacuum switch, acts on the slide valve and interrupts the compressed air supply, restoring it when the value returns below the minimum value.

Along with maintaining the vacuum level within the preset safety values, this modulation allows saving a considerable amount of compressed air, even in case of electricity failure. Once the work cycle is completed, an electric impulse deactivates the supply micro solenoid valve and, at the same time, the ejection micro solenoid valve for a quick restoration of the atmospheric pressure at the application.

AVG vacuum generators are set for the installation of a micro digital vacuum switch art. 12 05 11 at the application and, upon request, they can be supplied protection devices against shocks and accidental falls.

Also these vacuum generators can be installed in any position.

AVG vacuum generators are suited for controlling vacuum cup gripping systems, for handling sheet metal, glass, marble, ceramic, plastic, cardboard, wood, etc., and, in particular for the AUTOMOTIVE sector, which requires equipment with excellent performance and reduced overall dimensions and weight.

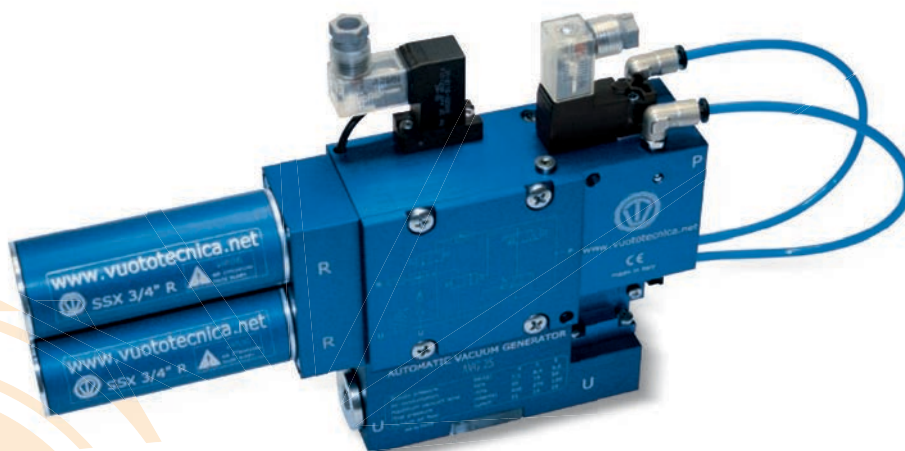

SINGLE-STAGE AND MULTI-FUNCTION VACUUM GENERATORS AVG 18 and AVG 25

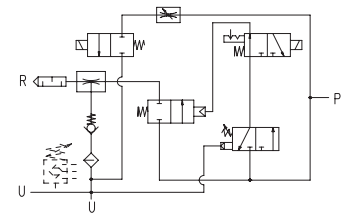
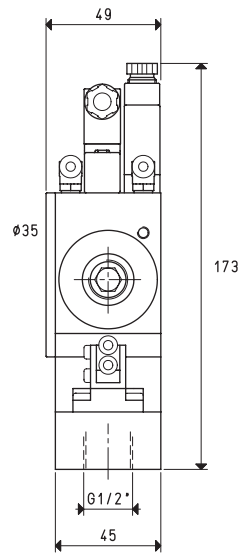
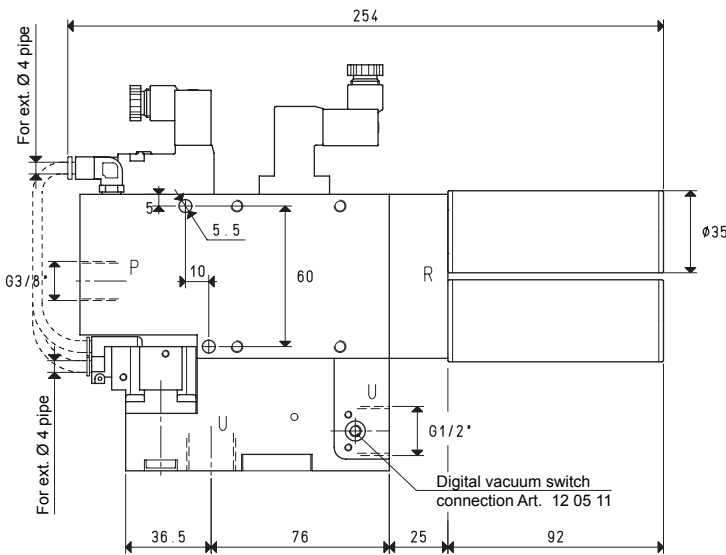
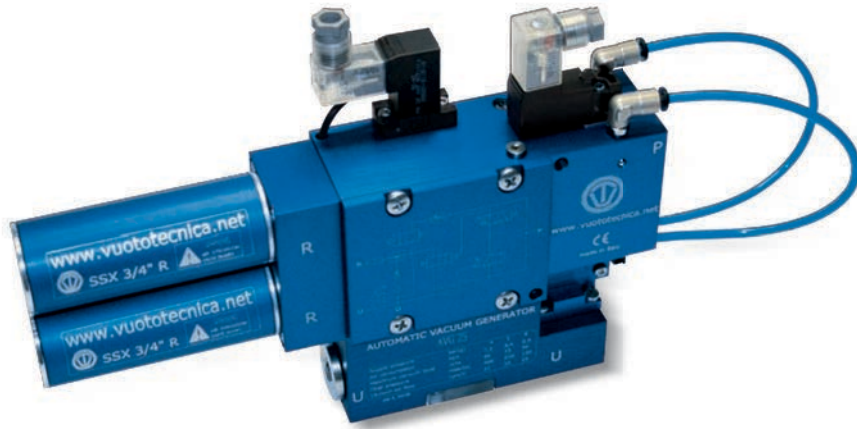

P=COMPRESSED AIR CONNECTION R=EXHAUST U=VACUUM CONNECTION

Art.				AVG 18		AVG 25	
Max. quantity of sucked air	cum/h	16.5	17.0	17.4	24.5	25.0	25.2
Max. vacuum level	-KPa	60	70	85	60	70	85
Final pressure	mbar abs.	400	300	150	400	300	150
Supply pressure	bar (g)	4	5	6	4	5	6
Air consumption	NI/s	4.3	5.3	6.4	6.5	8.0	9.6
Max. quantity of air blown at 6 bar (g)	l/min			140			140
Bistable supply solenoid valve	NO/NC			NO/NC			NO/NC
Electric absorption	W			1			1
Ejection solenoid valve position	NC			NC			NC
Electric absorption	W			4			4
Supply voltage	V			24 DC			24 DC
Class of protection	IP			65			65
Working temperature	°C			-10 / +60			-10 / +60
Noise level	dB(A)			63			65
Weight	Kg			1.67			1.67

Note: To order the generator provided with digital vacuum switch, add the letter V to the code (e.g.: AVG 25 V).

Note: All the vacuum data indicated in the table are valid at the normal atmospheric pressure of 1013 mbar and are obtained with a constant supply pressure.

Conversion ratio: inch = $\frac{mm}{25.4}$; pounds = $\frac{g}{453.6}$ = $\frac{Kg}{0.4536}$

GAS-NPT thread adapters available at page 1.117

SINGLE-STAGE AND MULTI-FUNCTION VACUUM GENERATORS AVG 18 and AVG 25

Air capacity (NI/s) at different vacuum levels (-Kpa)

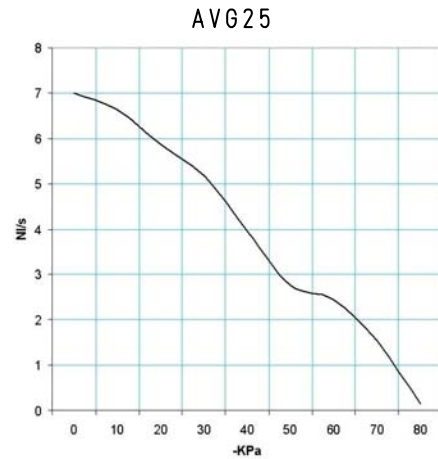
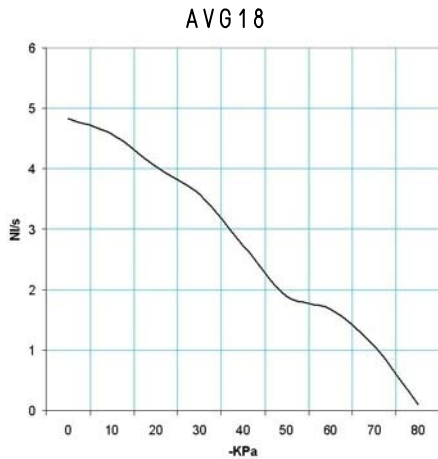

Generator art.	Supply press. bar (g)	Air consumption NI/s	Air capacity (NI/s) at different vacuum levels (-KPa)										Max. vacuum level -KPa
			0	10	20	30	40	50	60	70	80		
AVG 18	6.0	6.4	4.83	4.58	4.04	3.58	2.72	1.90	1.68	1.07	0.10	85	
AVG 25	6.0	9.6	7.00	6.63	5.86	5.18	3.94	2.76	2.44	1.54	0.15	85	

Evacuation time (ms/l= s/m^3) at different vacuum levels (-Kpa)

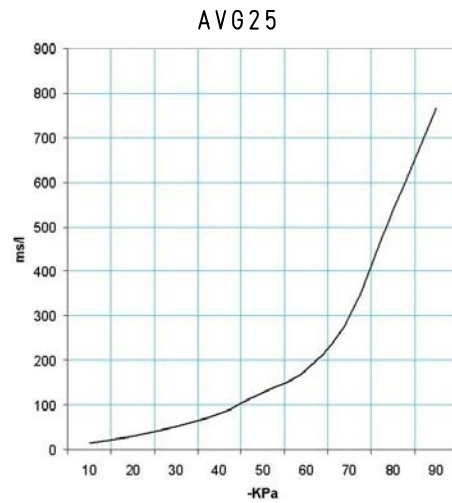
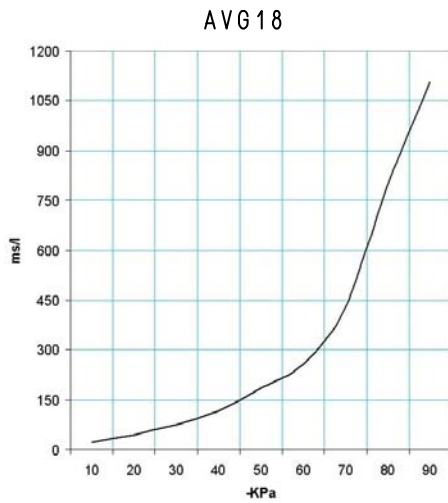

Generator art.	Supply press. bar (g)	Air consumption NI/s	Evacuation time (ms/l = s/m^3) at different vacuum levels (-KPa)										Max. vacuum level -KPa
			10	20	30	40	50	60	70	80	85		
AVG 18	6.0	6.4	22	44	75	115	185	258	430	798	1107	85	
AVG 25	6.0	9.6	15	30	52	80	128	178	297	538	764	85	

ACCESSORIES AND SPARE PARTS UPON REQUEST

Art.	AVG 18	AVG 25
Sealing kit	art.	00 KIT AVG 18
Cables with solenoid valve connectors provided with built-in electronic device in the male M2 connector	art.	00 15 309
Exhaust silencer	art.	SSX 3/4 R
Rear aluminium shockproof protection plate	art.	00 15 271
Front aluminium shockproof protection plate	art.	00 15 272
Digital micro vacuum switch	art.	12 05 11
Bistable supply solenoid valve	art.	00 15 297
Blowing solenoid valve NC	art.	00 15 175

3D drawing available at www.vuototecnica.net

SINGLE-STAGE AND MULTI-FUNCTION VACUUM GENERATORS AVG 18 P and AVG 25 P



Protection devices

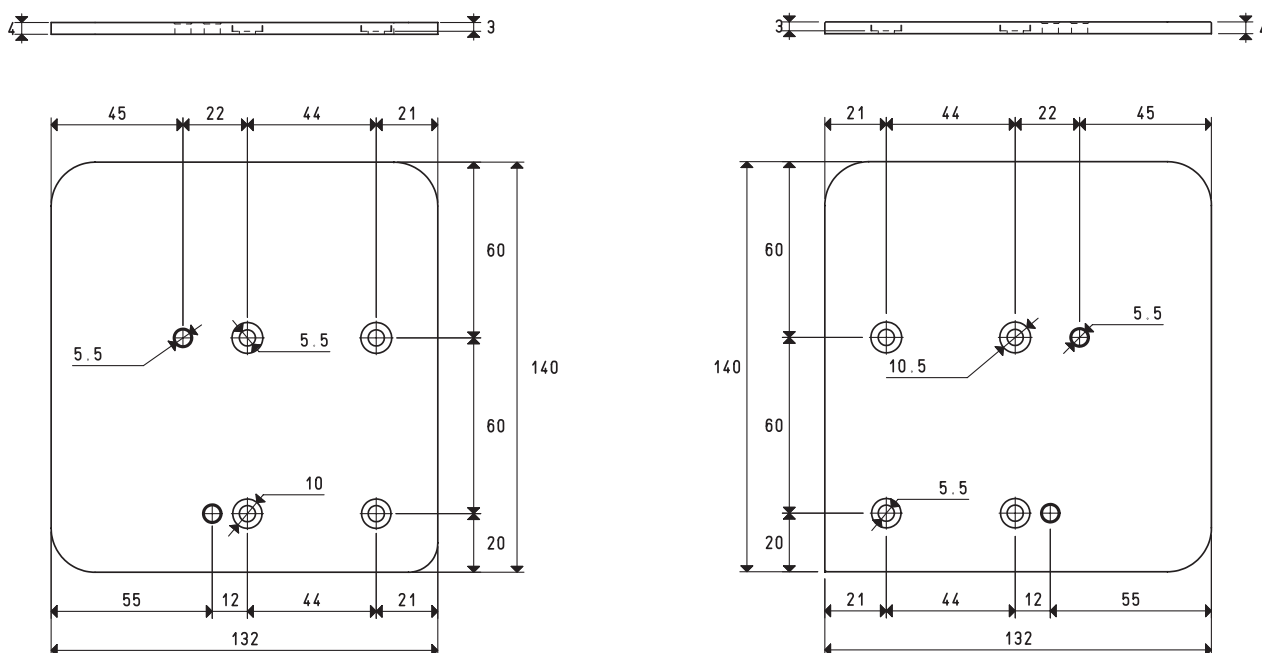

Art.	Description
00 15 271	Rear shockproof protection

Art.	Description
00 15 272	Front shockproof protection

Note: To order the generator provided with digital vacuum switch, add the letter V to the code (e.g.: AVG 25 P V).

ACCESSORIES AND SPARE PARTS FOR SINGLE-STAGE AND MULTI-FUNCTION VACUUM GENERATORS SERIES AVG

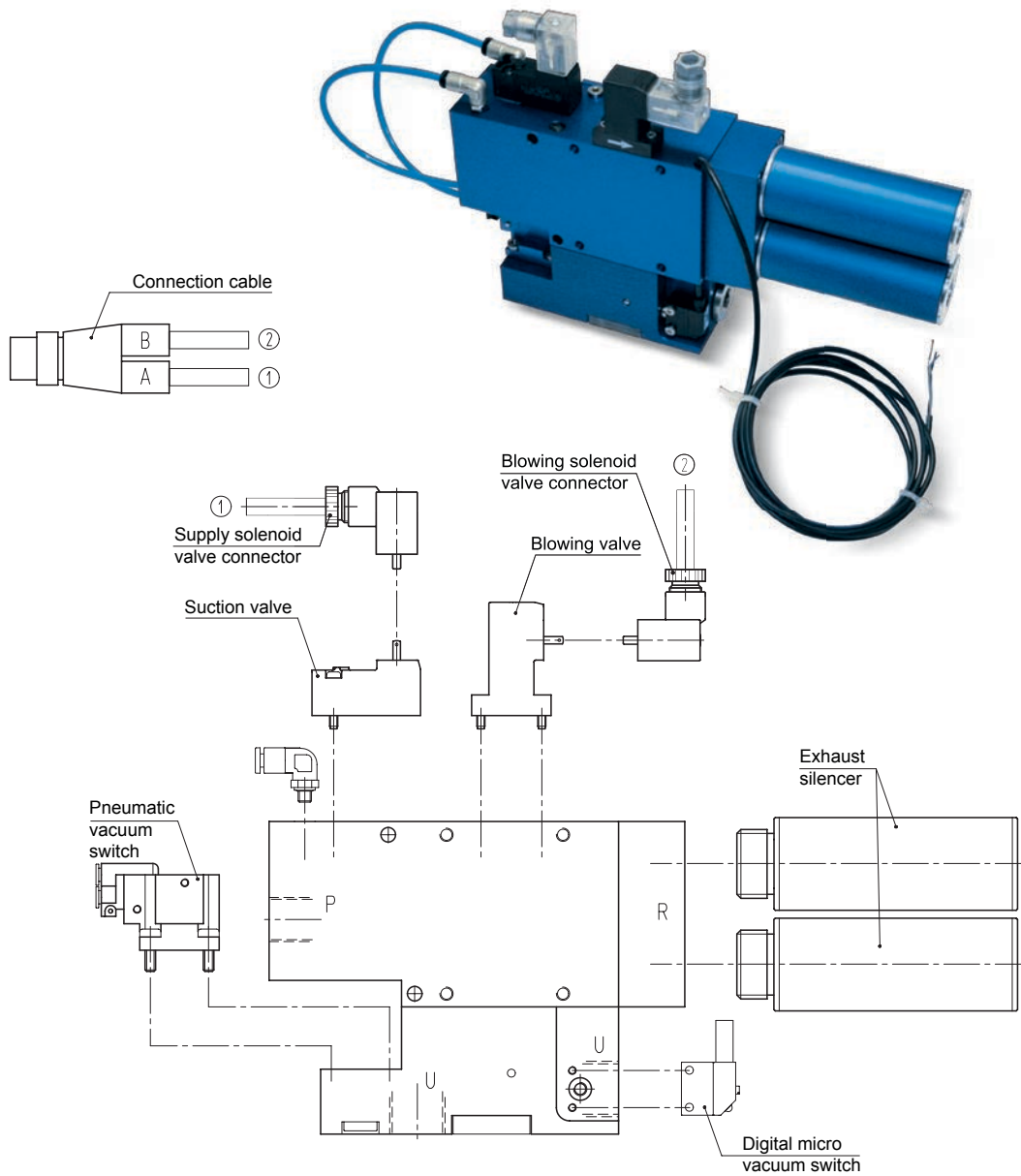

Cable with built-in electronic device

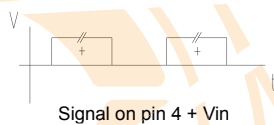
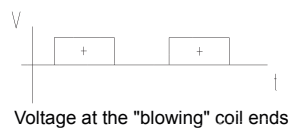
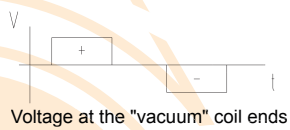
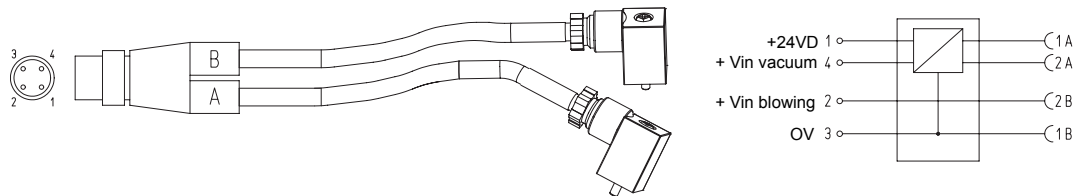

N°	Description
00 15 309	Cable with solenoid valve connectors with built-in electronic device in the male M12 connector.

ACCESSORIES AND SPARE PARTS FOR SINGLE-STAGE AND MULTI-FUNCTION VACUUM GENERATORS SERIES AVG

Digital micro vacuum switch



Art.	Description
12 05 11	Digital micro vacuum switch

Connector



Art.	Description
00 15 157	Connector with solenoid valve LED

Bistable micro solenoid valve



Art.	Description
00 15 297	Bistable supply solenoid valve

Micro solenoid valve NC

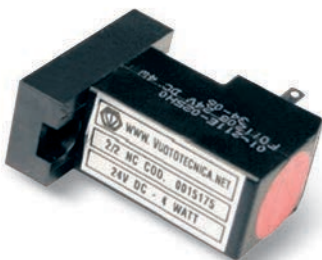

Art.	Description
00 15 175	Blowing solenoid valve NC

Silencer



Art.	Description
SSX 3/4" R	Exhaust silencer

MULTI-STAGE VACUUM GENERATORS PVP 12 MX and 25 MX

This new range of multiple ejector vacuum generators represents the natural evolution of the PVP 12M and 25M generators. In fact, given the same air consumption and final vacuum level, the maximum suction capacity is increased from 15 to 21 cum/h and from 25 to 31 cum/h respectively.

The body and the lid are made with anodised aluminium, all the ejectors are made with stainless steel, as well as the fixing screws.

The state of the art seal in EPDM and is never in contact with the sucked fluid. The reed valves, on the other hand, are made with silicon as a standard, and viton, upon request. The devices are also equipped with two new vacuum connections, apart from the existing one, and one for the possible connection to control or measuring devices.

As a standard, the devices are equipped with a vacuum gauge, a quick coupler for compressed air supply and metal locking caps for the unused connections.

The exhaust air connections are threaded in order to allow the installation of the new SSX silencers, for a further noise reduction.

They are perfectly interchangeable with the previous generators.

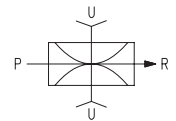
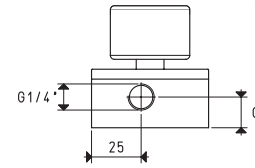
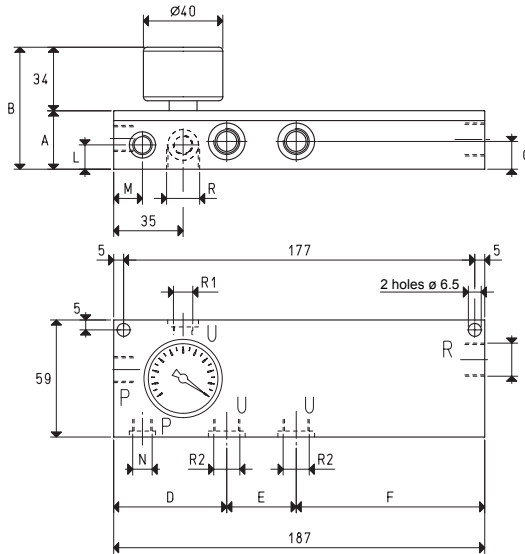

P=COMPRESSED AIR CONNECTION R=EXHAUST U=VACUUM CONNECTION

Art.		PVP 12 MX				PVP 25 MX	
Max. quantity of sucked air	cum/h	16.0	18.0	21.0	25.0	28.0	31.0
Max. vacuum level	-KPa	65	85	90	65	85	90
Final pressure	mbar abs.	350	150	100	350	150	100
Supply pressure	bar (g)	4	5	6	4	5	6
Air consumption	NI/s	1.3	1.5	1.8	2.3	2.7	3.2
Working temperature	°C			-20 / +80			-20 / +80
Noise level	dB(A)			65			70
Weight	g			660			960
A				29.5			45.5
B				63.5			79.5
C				15.5			20.7
D				57.0			60.5
E				35.0			37.0
F				95.0			89.5
G				14.0			20.7
L				--			20.75
M				--			14.5
N				--			G1/8"
I	Exhaust connection	∅		G3/8"			N° 4 x G1/4"
R	Vacuum connection	∅		G3/8"			G3/8"
R 1	Auxiliary vacuum connection	∅		G1/8"			G1/8"
R 2	Additional vacuum connection	∅		G1/4"			G1/2"
Spare parts							
Sealing kit and reed valve	art.			00 KIT PVP 12 MX			00 KIT PVP 25 MX
Vacuum gauge	art.			09 03 15			09 03 15

Note: All the vacuum data indicated in the table are valid at the normal atmospheric pressure of 1013 mbar and are obtained with a constant supply pressure.

3D drawing available at www.vuototecnica.net

MULTI-STAGE VACUUM GENERATORS PVP 12 MX and 25 MX

Air capacity (NI/s) at different vacuum levels (-Kpa)

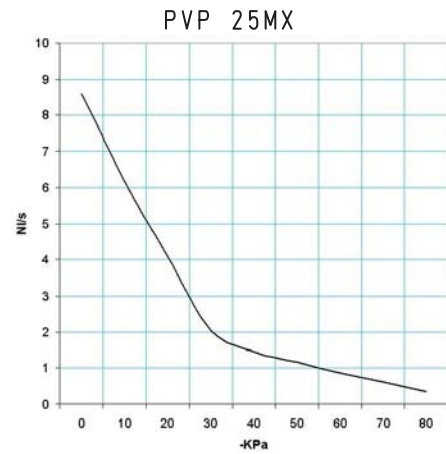
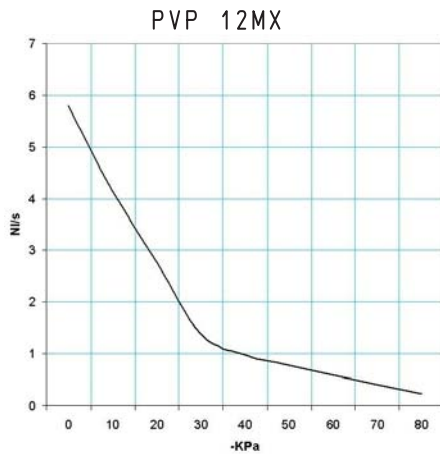

Generator art.	Supply press. bar (g)	Air consumption NI/s	Air capacity (NI/s) at different vacuum levels (-KPa)										Max. vacuum level -KPa
			0	10	20	30	40	50	60	70	80		
PVP 12 MX	6.0	1.8	5.80	4.14	2.76	1.38	0.98	0.78	0.59	0.41	0.23	90	
PVP 25 MX	6.0	3.2	8.61	6.15	4.10	2.05	1.46	1.17	0.88	0.61	0.35	90	

Evacuation time (ms/l=s/m³) at different vacuum levels (-Kpa)

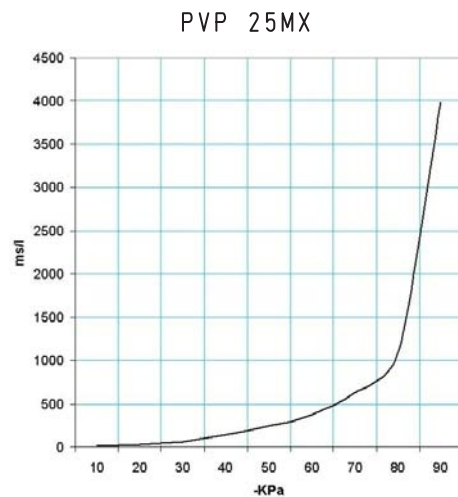
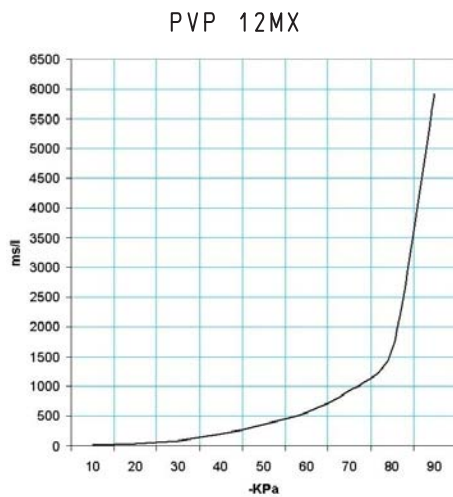

Generator art.	Supply press. bar (g)	Air consumption NI/s	Evacuation time (ms/l = s/m ³) at different vacuum levels (-KPa)										Max. vacuum level -KPa
			10	20	30	40	50	60	70	80	85		
PVP 12 MX	6.0	1.8	15.4	38.7	85.1	204.4	365.9	559.8	929.4	1607.8	5916	90	
PVP 25 MX	6.0	3.2	10.4	26.0	57.3	137.7	246.5	377.1	626.0	1083.1	3986	90	

Accessories upon request

Silencer art. SSX 3/8" for PVP 12MX

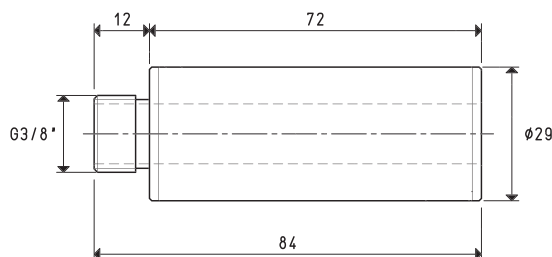

4 silencers art. SSX 1/4 for PVP 25 MX

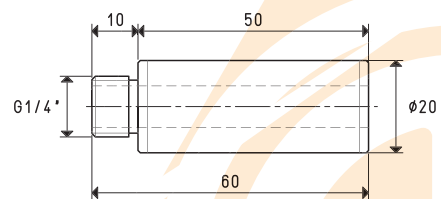

MULTI-STAGE VACUUM GENERATORS PVP 40 ÷ 300 M

This new range of multi-stage vacuum generators have been designed to be assembled onto OCTOPUS vacuum systems and represents a true evolution of traditional vane vacuum pumps. They feature state of the art ejectors and boast an excellent ratio between the consumed and the sucked air to the benefit of operative consumption. They also allow adjusting the vacuum level and capacity according to the air supply pressure.

When designing these vacuum generators, our focus was on noise; In fact, they are free of moving parts subject to vibrations and wear and they are perfectly soundproofed, therefore, their operation is particularly silent.

Moreover, their operation being based on Venturi's principle, they do not develop heat.

The light alloys used to make them have allowed a considerable reduction of their weight. A good filtration of the compressed air supply and of the sucked one allows discharging air free from oil vapours, water condensation and impurities and reducing maintenance to a simple regular filtre cleaning.

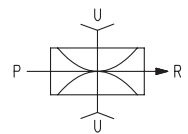
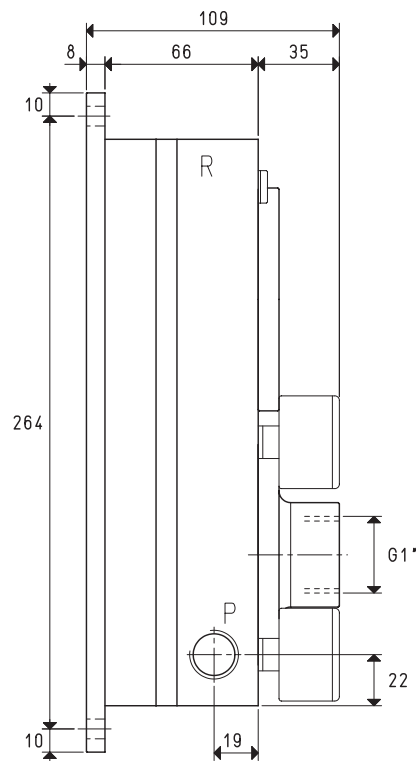
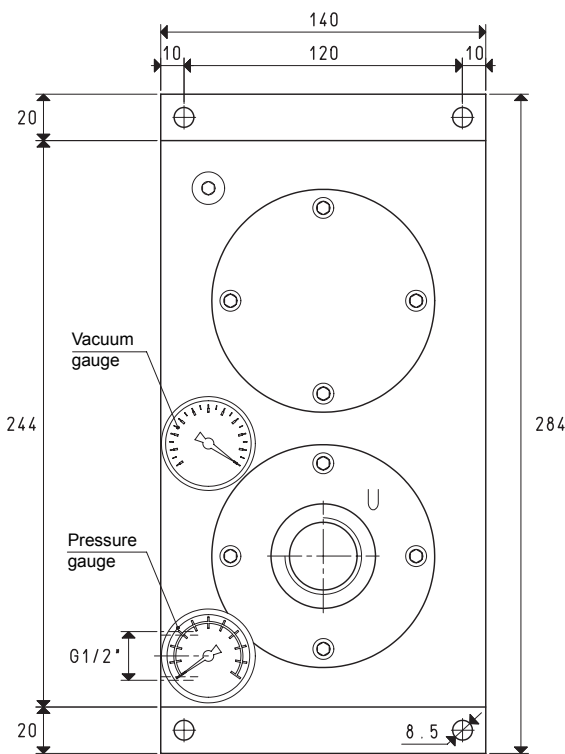

P=COMPRESSED AIR CONNECTION

R=EXHAUST

U=VACUUM CONNECTION

Art.		PVP 40 M			PVP 70 M			PVP 100 M		
Max. quantity of sucked air	cum/h	36	39	42	65	73	80	88	98	108
Max. vacuum level	-KPa	65	82	90	65	82	90	65	82	90
Final pressure	mbar abs.	350	180	100	350	180	100	350	180	100
Supply pressure	bar (g)	4	5	6	4	5	6	4	5	6
Air consumption	NI/s	2.3	2.7	3.2	4.9	5.7	6.6	7.2	8.5	9.8
Working temperature	°C	-20 / +80			-20 / +80			-20 / +80		
Noise level	dB(A)	67			68			70		
Weight	Kg	4.2			4.2			4.2		
Spare parts										
Sealing kit e disc valves	art.	00 KIT PVP 40 M			00 KIT PVP 70 M			00 KIT PVP 100 M		
Vacuum gauge	art.	09 03 15			09 03 15			09 03 15		
Pressure gauge	art.	09 03 25			09 03 25			09 03 25		

Note: All the vacuum data indicated in the table are valid at the normal atmospheric pressure of 1013 mbar and are obtained with a constant supply pressure.

By adding the letter R to the article, the generator will be supplied with a built-in check valve (E.g.: PVP 40 MR).

3D drawing available at www.vuototecnica.net

MULTI-STAGE VACUUM GENERATORS PVP 40 M, 70 M and 100 M

Air capacity (NI/s) at different vacuum levels (-Kpa)

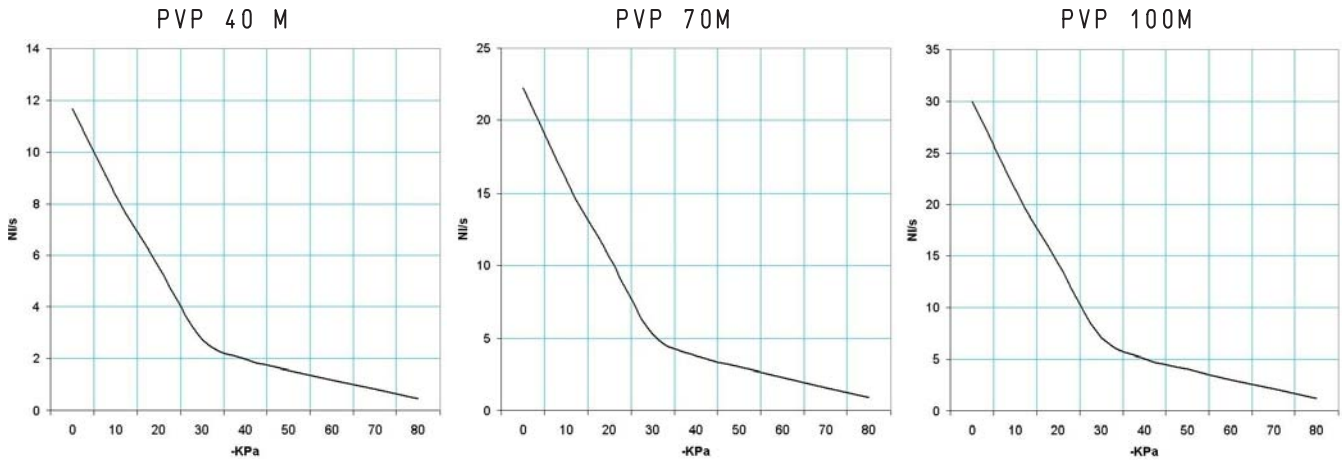

Generator art.	Supply press. bar (g)	Air consumption NI/s	Air capacity (NI/s) at different vacuum levels (-KPa)										Max. vacuum level -KPa
			0	10	20	30	40	50	60	70	80		
PVP 40 M	6.0	3.2	11.66	8.32	5.55	2.77	1.98	1.58	1.19	0.83	0.47	90	
PVP 70 M	6.0	6.6	22.22	15.87	10.58	5.29	3.77	3.02	2.27	1.58	0.90	90	
PVP 100 M	6.0	9.8	30.00	21.42	14.28	7.14	5.10	4.08	3.06	2.14	1.22	90	

Evacuation time (ms/l=s/m³) at different vacuum levels (-Kpa)

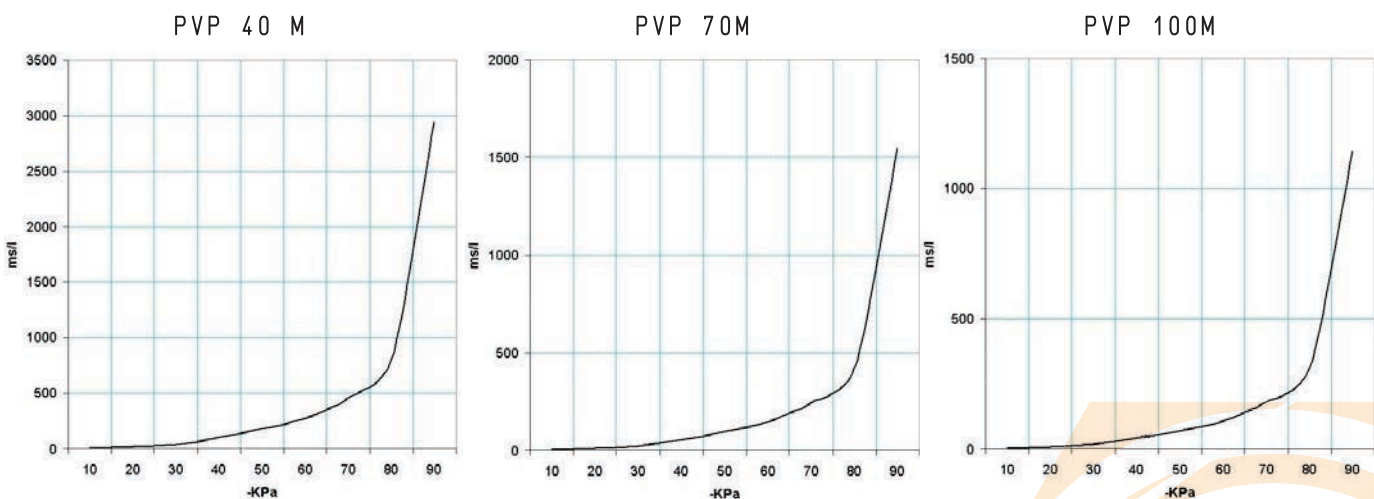

Generator art.	Supply press. bar (g)	Air consumption NI/s	Evacuation time (ms/l = s/m ³) at different vacuum levels (-KPa)									Max. vacuum level -KPa
			10	20	30	40	50	60	70	80	90	
PVP 40 M	6.0	3.2	7.7	19.2	42.3	101.6	182.0	278.4	462.3	799.8	2943	90
PVP 70 M	6.0	6.6	4.0	10.1	22.2	53.3	95.5	146.1	242.6	419.7	1544	90
PVP 100 M	6.0	9.8	3.0	7.4	16.4	39.5	70.7	108.2	179.6	310.8	1144	90

MULTI-STAGE VACUUM GENERATORS PVP 140 M, 170 M and 200 M

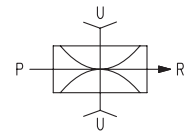
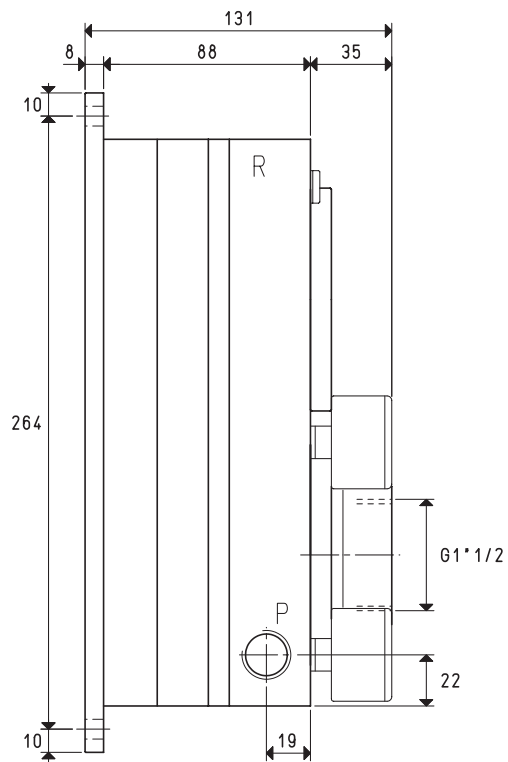
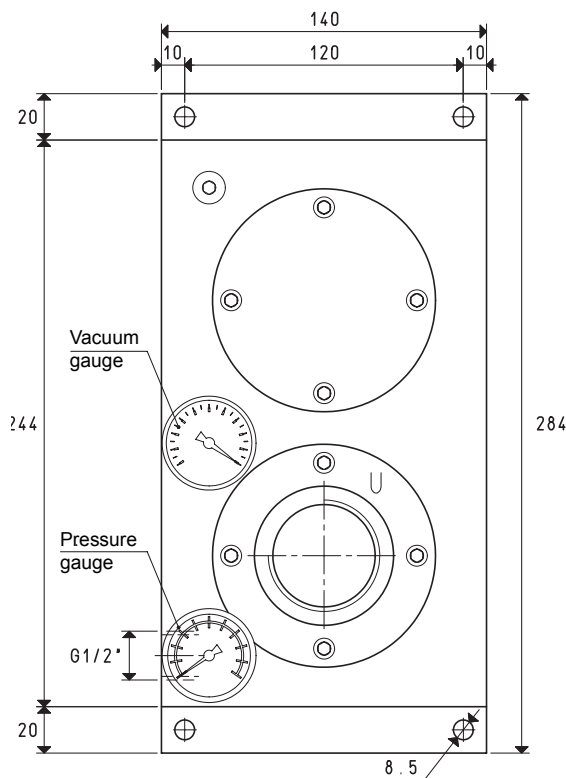

P=COMPRESSED AIR CONNECTION R=EXHAUST U=VACUUM CONNECTION

Art.		PVP 140 M			PVP 170 M			PVP 200 M		
		125	140	152	150	168	182	170	188	200
Max. quantity of sucked air	cum/h	125	140	152	150	168	182	170	188	200
Max. vacuum level	-KPa	65	82	90	65	82	90	65	82	90
Final pressure	mbar abs.	350	180	100	350	180	100	350	180	100
Supply pressure	bar (g)	4	5	6	4	5	6	4	5	6
Air consumption	NI/s	9.6	11.4	13.0	12.1	14.2	16.3	14.2	16.9	19.4
Working temperature	°C	-20 / +80			-20 / +80			-20 / +80		
Noise level	dB(A)	70			71			72		
Weight	Kg	5.1			5.1			5.1		
Spare parts										
Sealing kit e disc valves	art.	00 KIT PVP 140 M			00 KIT PVP 170 M			00 KIT PVP 200 M		
Vacuum gauge	art.	09 03 15			09 03 15			09 03 15		
Pressure gauge	art.	09 03 25			09 03 25			09 03 25		

Note: All the vacuum data indicated in the table are valid at the normal atmospheric pressure of 1013 mbar and are obtained with a constant supply pressure.

By adding the letter R to the article, the generator will be supplied with a built-in check valve (E.g.: PVP 140 MR).

3D drawing available at www.vuototecnica.net

MULTI-STAGE VACUUM GENERATORS PVP 140 M, 170 M and 200 M

Air capacity (NI/s) at different vacuum levels (-Kpa)

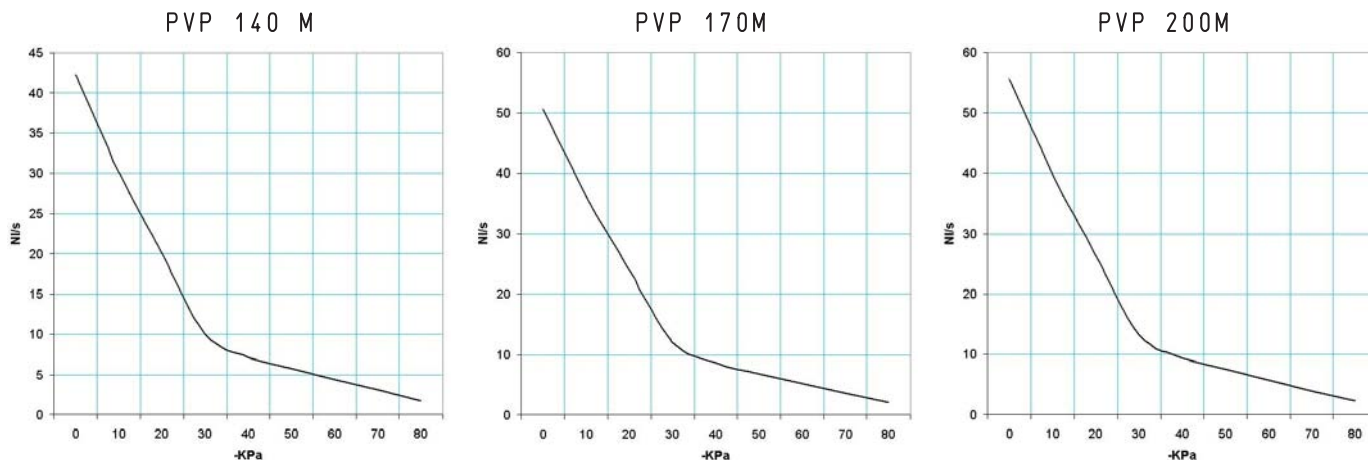

Generator art.	Supply press. bar (g)	Air consumption NI/s	Air capacity (NI/s) at different vacuum levels (-KPa)										Max. vacuum level -KPa
			0	10	20	30	40	50	60	70	80	90	
PVP 140 M	6.0	13.0	42.22	30.15	20.10	10.05	7.18	5.74	4.31	3.02	1.72	90	
PVP 170 M	6.0	16.3	50.55	36.10	24.07	12.03	8.59	6.87	5.17	3.61	2.06	90	
PVP 200 M	6.0	19.4	55.55	39.67	26.45	13.22	9.44	7.55	5.68	3.97	2.27	90	

Evacuation time (ms/l=s/m³) at different vacuum levels (-Kpa)

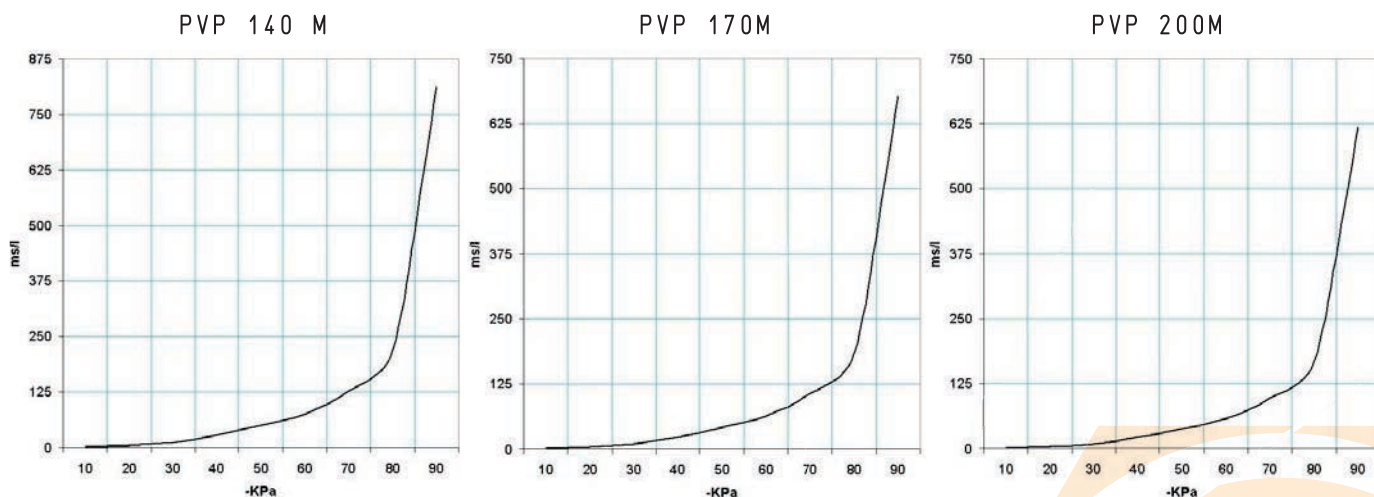

Generator art.	Supply press. bar (g)	Air consumption NI/s	Evacuation time (ms/l = s/m³) at different vacuum levels (-KPa)										Max. vacuum level -KPa
			10	20	30	40	50	60	70	80	90		
PVP 140 M	6.0	13.0	2.1	5.3	11.7	28.0	50.2	76.9	127.6	220.8	812	90	
PVP 170 M	6.0	16.3	1.7	4.4	9.7	23.4	42.0	64.2	106.6	184.5	678	90	
PVP 200 M	6.0	19.4	1.6	4.0	8.9	21.3	38.2	58.4	97.0	167.8	618	90	

MULTI-STAGE VACUUM GENERATORS PVP 250 M and 300 M

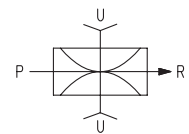
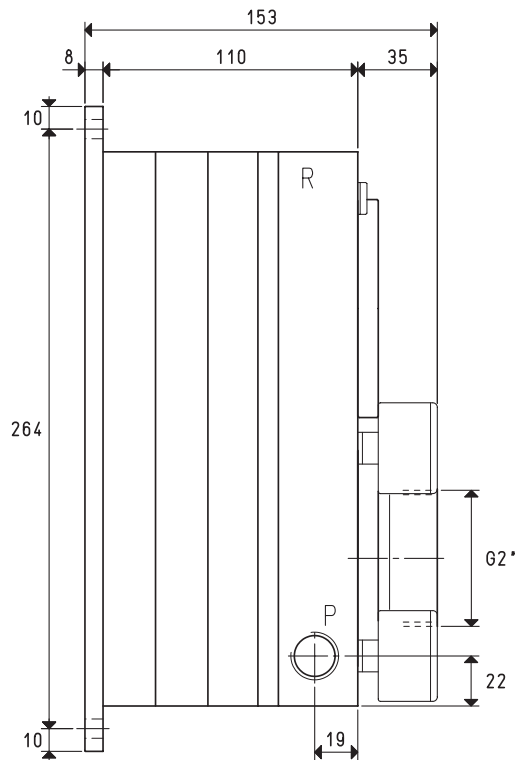
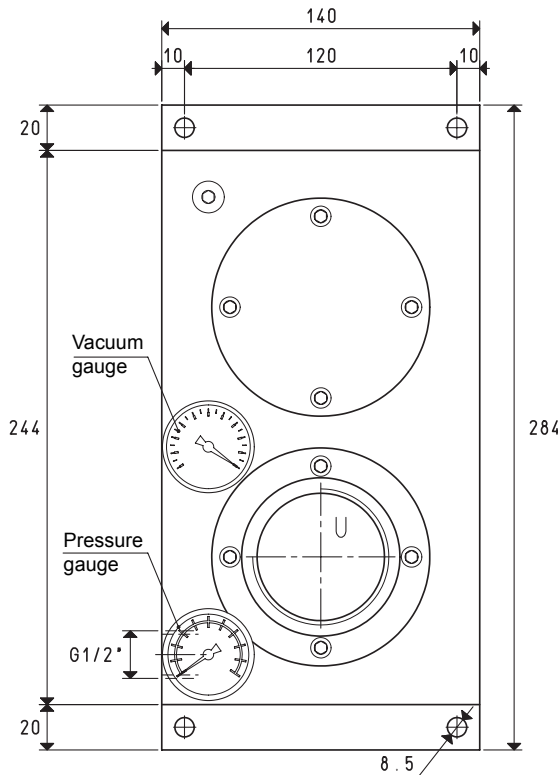

P=COMPRESSED AIR CONNECTION

R=EXHAUST

U=VACUUM CONNECTION

Art.				PVP 250 M		PVP 300 M	
Max. quantity of sucked air	cum/h	224	252	280	240	290	320
Max. vacuum level	-kPa	65	82	90	65	82	90
Final pressure	mbar abs.	350	180	100	350	180	100
Supply pressure	bar (g)	4	5	6	4	5	6
Air consumption	NI/s	17.3	20.7	24.0	20.4	24.8	29.0
Working temperature	°C			-20 / +80			-20 / +80
Noise level	dB(A)			72			74
Weight	Kg			6.0			6.0
Spare parts							
Sealing kit e disc valves	art.			00 KIT PVP 250 M			00 KIT PVP 300 M
Vacuum gauge	art.			09 03 15			09 03 15
Pressure gauge	art.			09 03 25			09 03 25

Note: All the vacuum data indicated in the table are valid at the normal atmospheric pressure of 1013 mbar and are obtained with a constant supply pressure.

By adding the letter R to the article, the generator will be supplied with a built-in check valve (E.g.: PVP 250 MR).

3D drawing available at www.vuototecnica.net

MULTI-STAGE VACUUM GENERATORS PVP 250 M and 300 M

Air capacity (NI/s) at different vacuum levels (-Kpa)

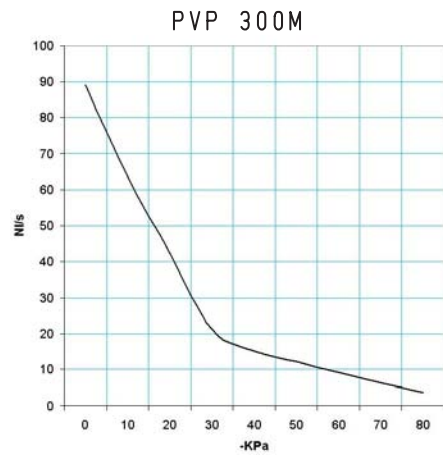
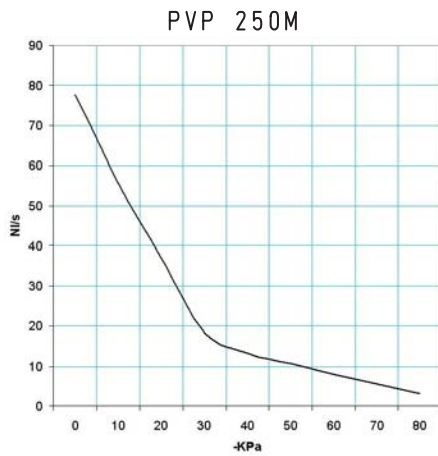

Generator art.	Supply press. bar (g)	Air consumption NI/s	Air capacity (NI/s) at different vacuum levels (-KPa)									Max. vacuum level -KPa
			0	10	20	30	40	50	60	70	80	
PVP 250 M	6.0	24.0	77.77	55.55	37.03	18.51	13.22	10.58	7.95	5.56	3.17	90
PVP 300 M	6.0	29.0	88.88	63.48	42.32	21.16	15.11	12.09	9.09	6.35	3.63	90

Evacuation time (ms/l=s/m³) at different vacuum levels (-Kpa)

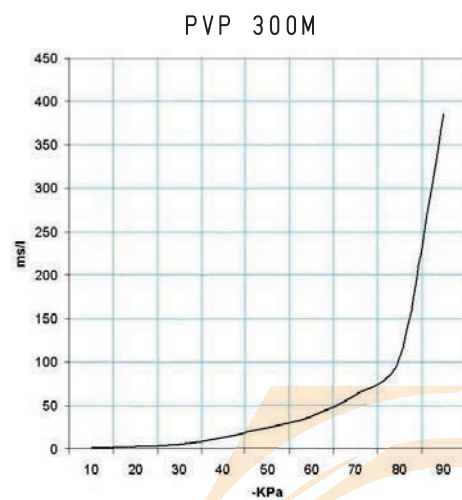
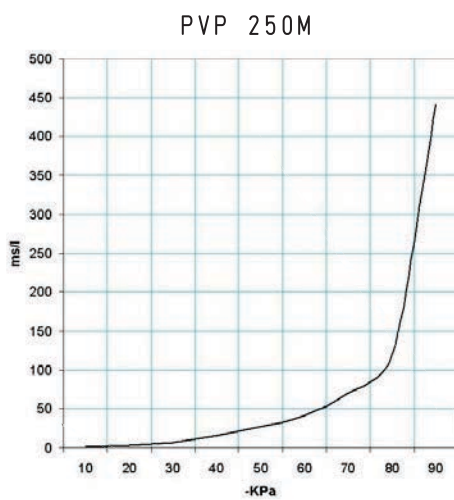

Generator art.	Supply press. bar (g)	Air consumption NI/s	Evacuation time (ms/l = s/m ³) at different vacuum levels (-KPa)								Max. vacuum level -KPa	
			10	20	30	40	50	60	70	80		90
PVP 250 M	6.0	24.0	1.1	2.9	6.4	15.2	27.3	41.8	69.3	119.9	442	90
PVP 300 M	6.0	29.0	1.0	2.5	5.5	13.3	23.8	36.5	60.6	104.9	386	90

MULTI-STAGE VACUUM GENERATORS PVP 25 ÷ 75 MDX

This new range of generators represent the natural evolution of the PVP 25 ÷ 75 MD multiple ejector vacuum generators and they boast an excellent performance. In fact, given the same air consumption values and the same final vacuum level, the maximum suction capacity is increased by 10 ÷ 12% compared to the previous range. The body and lid are made with anodised aluminium, all the ejectors are made with stainless steel, as well as the fixing screws. The state of the art seal is in EPDM and is never in contact with the sucked fluid; the reed valves, on the other hand, are made with silicon as a standard and in viton, upon request. These new devices contain a housing for the installation, upon request, of a pneumatic vacuum switch, that, associated with a pneumatic slide valve and a special check valve, allows making an energy saving device. As a standard, these devices are equipped with a vacuum gauge a pressure gauge, a silencer on the exhaust and a quick coupler for the compressed air supply. This new range of vacuum generators is perfectly interchangeable with the previous one.

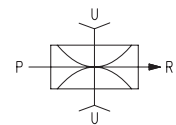
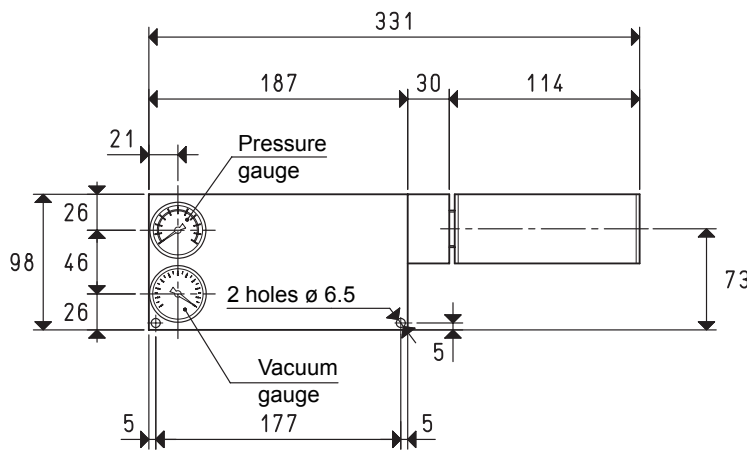
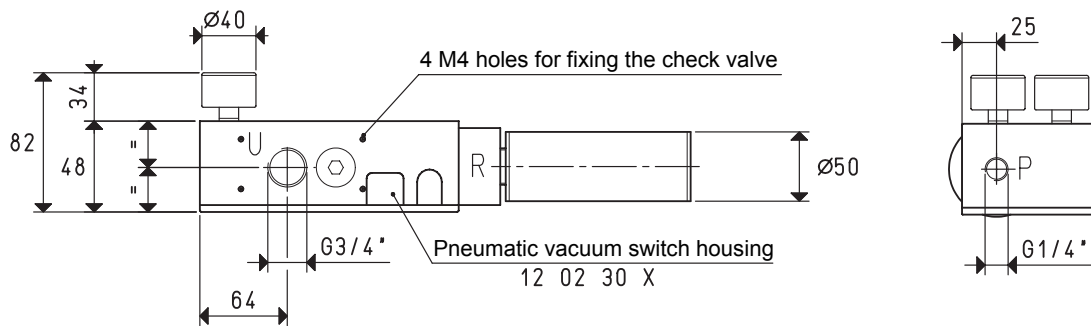

Art.	P=COMPRESSED AIR CONNECTION	R=EXHAUST	U=VACUUM CONNECTION							
			PVP 25 MDX			PVP 35 MDX		PVP 50 MDX		
Max. quantity of sucked air	cum/h	35	39	43	47	52	57	57	62	68
Max. vacuum level	-KPa	65	82	90	65	82	90	65	82	90
Final pressure	mbar abs.	350	180	100	350	180	100	350	180	100
Supply pressure	bar (g)	4	5	6	4	5	6	4	5	6
Air consumption	NI/s	2.3	2.8	3.2	3.4	4.1	4.8	4.7	5.6	6.5
Working temperature	°C			-20 / +80			-20 / +80		-20 / +80	
Noise level	dB(A)			58			58		60	
Weight	Kg			1.71			1.73		1.75	
Spare parts										
Sealing kit and reed valve	art.			00 KIT PVP 25 MDX			00 KIT PVP 35 MDX		00 KIT PVP 50 MDX	
Vacuum gauge	art.			09 03 15			09 03 15		09 03 15	
Pressure gauge	art.			09 03 25			09 03 25		09 03 25	
Silencer	art.			SSX 3/4"			SSX 3/4"		SSX 3/4"	

Note: All the vacuum data indicated in the table are valid at the normal atmospheric pressure of 1013 mbar and are obtained with a constant supply pressure.

MULTI-STAGE VACUUM GENERATORS PVP 25 MDX, 35 MDX and 50 MDX

Air capacity (NI/s) at different vacuum levels (-KPa)

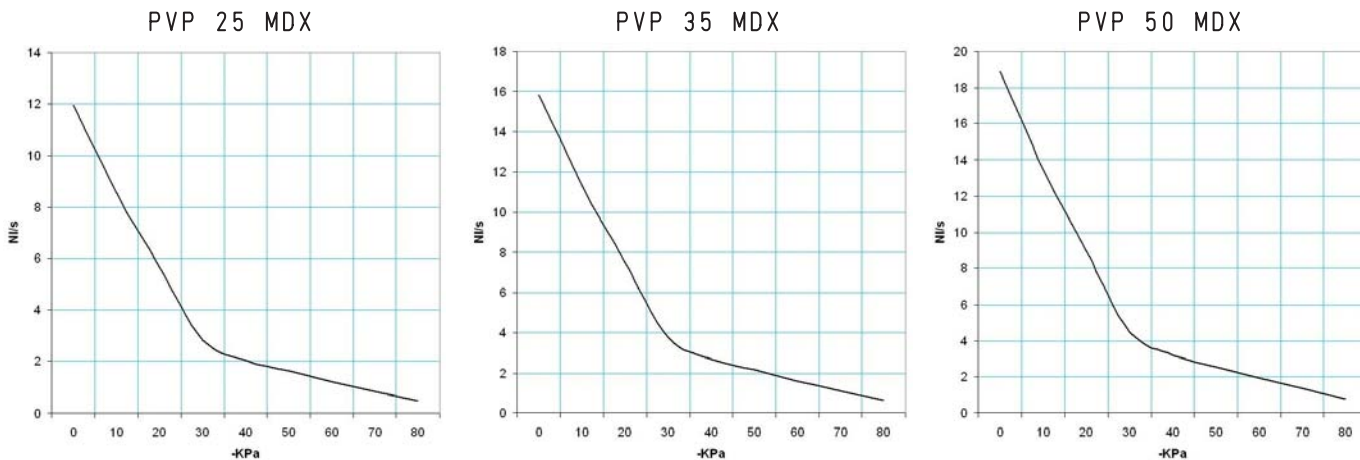

Generator art.	Supply press. bar (g)	Air consumption NI/s	Air capacity (NI/s) at different vacuum levels (-KPa)										Max. vacuum level -KPa
			0	10	20	30	40	50	60	70	80		
PVP 25 MDX	6.0	3.2	11.94	8.53	5.68	2.84	2.03	1.62	1.22	0.85	0.48	90	
PVP 35 MDX	6.0	4.8	15.83	11.30	7.53	3.76	2.69	2.15	1.61	1.13	0.64	90	
PVP 50 MDX	6.0	6.5	18.88	13.48	8.99	4.49	3.21	2.56	1.93	1.35	0.77	90	

Evacuation time (ms/l=s/m³) at different vacuum levels (-KPa)

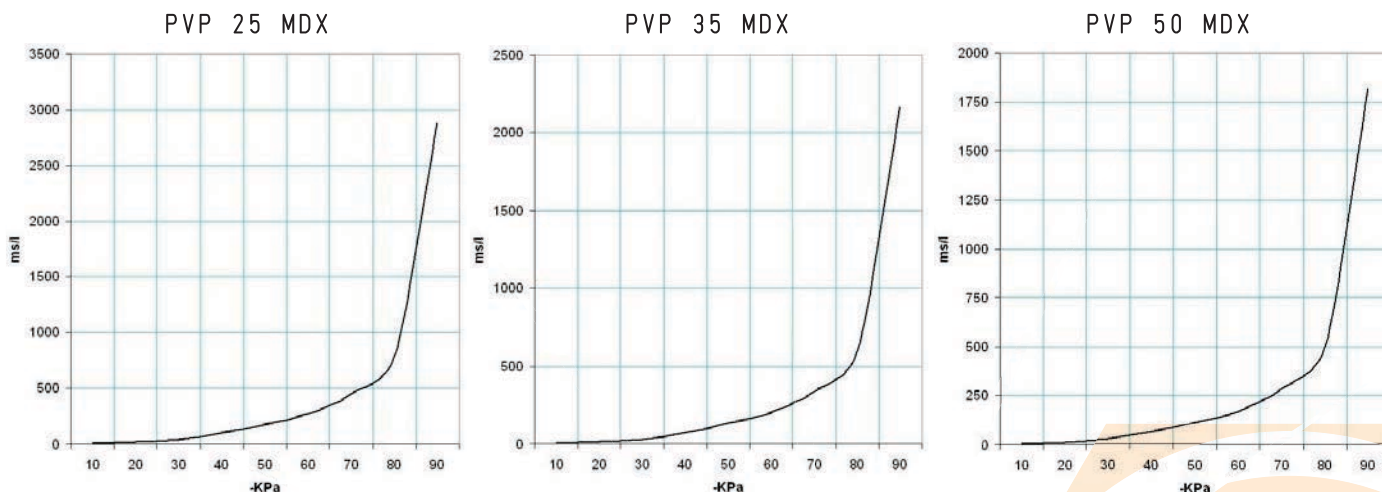

Generator art.	Supply press. bar (g)	Air consumption NI/s	Evacuation time (ms/l = s/m ³) at different vacuum levels (-KPa)										Max. vacuum level -KPa
			10	20	30	40	50	60	70	80	90		
PVP 25 MDX	6.0	3.2	7.5	18.8	41.3	99.3	177.7	271.9	451.4	781.0	2874	90	
PVP 35 MDX	6.0	4.8	5.6	14.1	31.2	74.9	134.0	205.1	340.5	589.1	2618	90	
PVP 50 MDX	6.0	6.5	4.7	11.9	26.2	62.8	112.4	172.0	285.5	494.0	1818	90	

MULTI-STAGE VACUUM GENERATORS PVP 60 MDX and 75 MDX

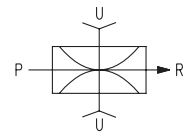
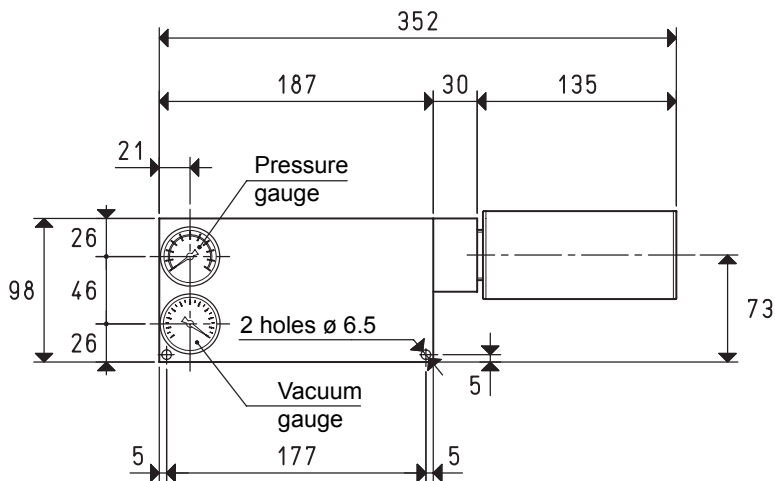
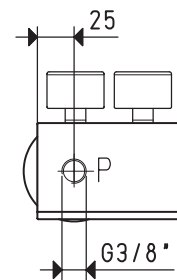
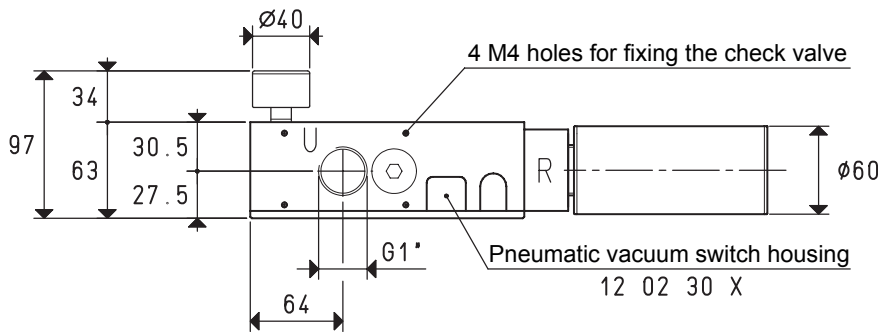

P=COMPRESSED AIR CONNECTION

R=EXHAUST

U=VACUUM CONNECTION

Art.		PVP 60 MDX				PVP 75 MDX	
Max. quantity of sucked air	cum/h	75	85	92	85	94	103
Max. vacuum level	-KPa	65	82	90	65	82	90
Final pressure	mbar abs.	350	180	100	350	180	100
Supply pressure	bar (g)	4	5	6	4	5	6
Air consumption	NI/s	5.9	7.0	8.2	7.0	8.4	9.8
Working temperature	°C	-20 / +80				-20 / 80	
Noise level	dB(A)	62				64	
Weight	Kg	1.90				1.92	
Spare parts							
Sealing kit and reed valve	art.	00 KIT PVP 60 MDX				00 KIT PVP 75 MDX	
Vacuum gauge	art.	09 03 15				09 03 15	
Pressure gauge	art.	09 03 25				09 03 25	
Silencer	art.	SSX 1"				SSX 1"	

Note: All the vacuum data indicated in the table are valid at the normal atmospheric pressure of 1013 mbar and are obtained with a constant supply pressure.

MULTI-STAGE VACUUM GENERATORS PVP 60 MDX and 75 MDX

Air capacity (NI/s) at different vacuum levels (-Kpa)

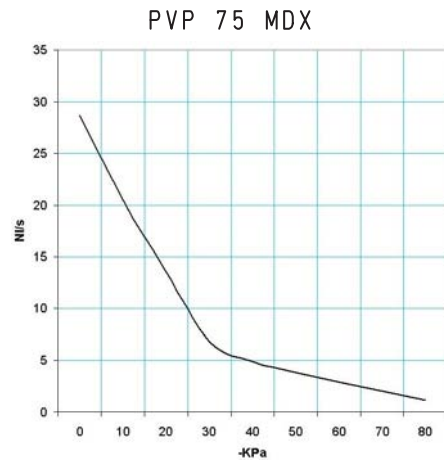
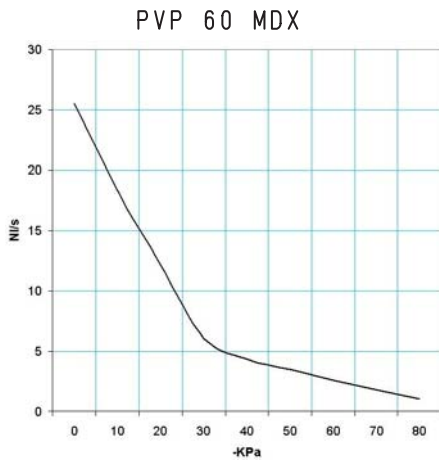

Generator art.	Supply press. bar (g)	Air consumption NI/s	Air capacity (NI/s) at different vacuum levels (-KPa)									Max. vacuum level -KPa
			0	10	20	30	40	50	60	70	80	
PVP 60 MDX	6.0	8.2	25.55	18.25	12.16	6.08	4.34	3.47	2.61	1.82	1.04	90
PVP 75 MDX	6.0	9.8	28.61	20.43	13.62	6.81	4.86	3.89	2.92	2.04	1.16	90

Evacuation time (ms/l=s/m³) at different vacuum levels (-Kpa)

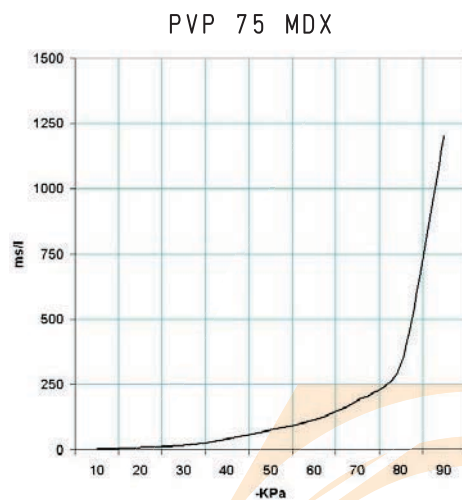
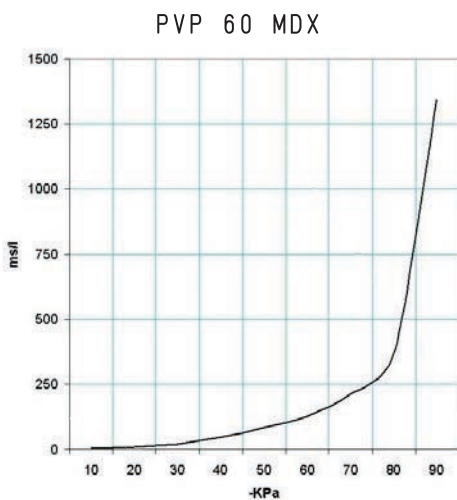

Generator art.	Supply press. bar (g)	Air consumption NI/s	Evacuation time (ms/l = s/m ³) at different vacuum levels (-KPa)									Max. vacuum level -KPa
			10	20	30	40	50	60	70	80	90	
PVP 60 MDX	6.0	8.2	3.5	8.8	19.3	46.4	83.0	127.0	211.0	365.0	1343	90
PVP 75 MDX	6.0	9.8	3.1	7.8	17.2	41.4	74.2	113.5	188.4	326.0	1200	90

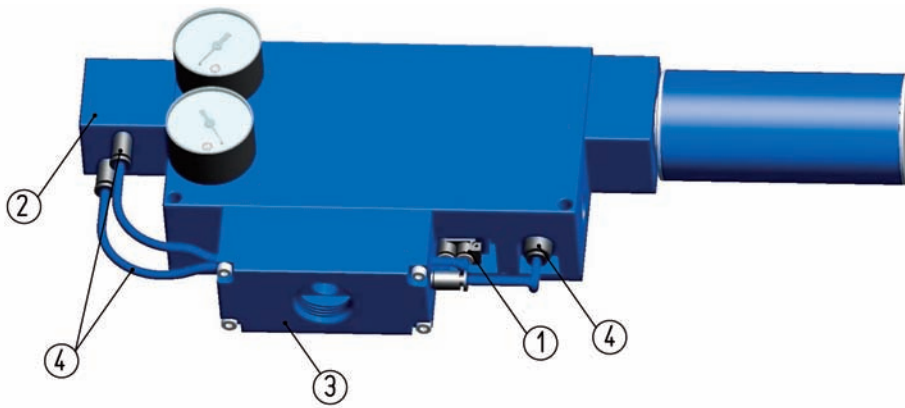

① - MINI PNEUMATIC VACUUM SWITCH

The vacuum switch removes a pneumatic signal as soon as a determined adjustable vacuum level is reached. The pressure differential between the set maximum value and the value of reset of the rest signal cannot be adjusted and it is equal to approximately 100 mbar.

The pneumatic vacuum switch installed on PVP 25 ÷ 75 MDX vacuum generators intervene on the supply slide valve and automatically maintain the maximum and minimum vacuum level within the differential level.

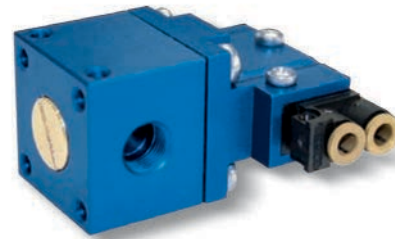
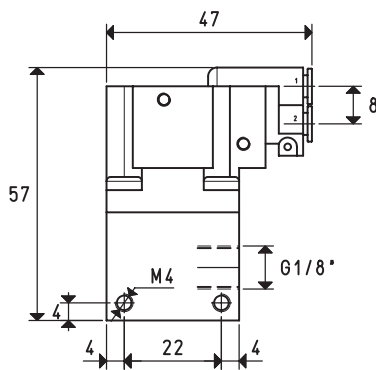

Art.	For generator art.	Weight g
12 02 30 X	PVP 25 ÷ 50 MDX	104
	PVP 60 ÷ 75 MDX	

② - SERVO-CONTROLLED SUPPLY SLIDE VALVE

This valve is provided with slide shutter that, once pneumatically activated by the vacuum switch or by alternative sources intercepts the generator compressed air supply, with pressure ranging from 1.5 and 7 bar (g).

The value is according to the generator supply connection.

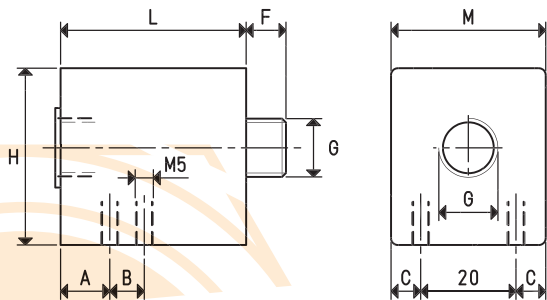

Art.	A	B	C	F	G Ø	H	L	M	Weight g	For generator art.
07 01 70	11.5	8.0	7.5	9.5	G1/4"	40	42	35	190	PVP 25 ÷ 50 MDX
07 02 70	13.5	9.5	12.5	9.5	G3/8"	50	51	45	420	PVP 60 ÷ 75 MDX

3D drawing available at www.vuototecnica.net

③ - MEMBRANE CHECK VALVE

This check valve has been specially designed for PVP 25 ÷ 75 MDX vacuum generators. Its distinctive feature, along with its shape, is its membrane check valve that guarantees minimal load loss, quick intervention and perfect sealing.

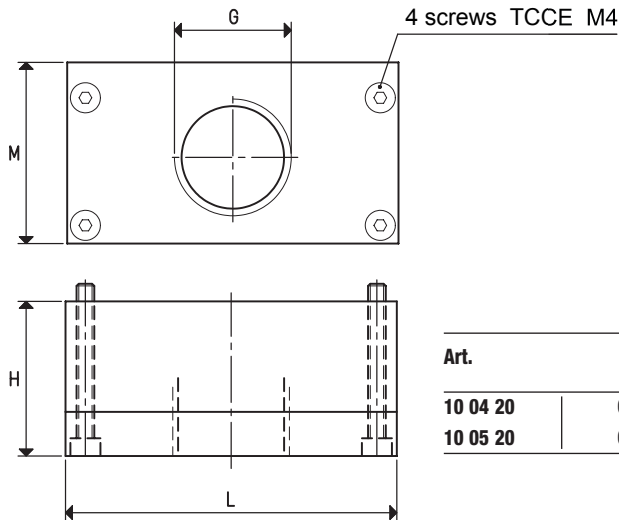

Art.	G Ø	H	L	M	Weight g	For generator art.
10 04 20	G3/4"	35	75	41	165	PVP 25 ÷ 50 MDX
10 05 20	G1"	48	113	58	458	PVP 60 ÷ 75 MDX

④ - HOSE KIT WITH FITTINGS

This hose kit is for connecting the vacuum switch to the supply slide valve and to the membrane check valve. On the hose ends are installed the special quick couplers to screw onto the valve and vacuum switch connections.

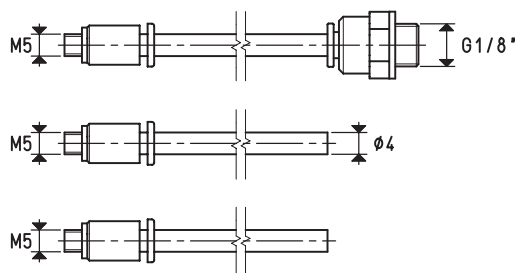

Art.	For generator art.	Weight g
00 15 308	PVP 25 ÷ 50 MDX PVP 60 ÷ 75 MDX	16

COMPLETE ES ENERGY SAVING
DEVICE KIT



Art.	For generator art.	Weight g
ES 01	PVP 25 ÷ 50 MDX	475
ES 02	PVP 60 ÷ 75 MDX	998

Note: To order multi-stage vacuum generators with energy-saving device, add the letters ES to the the code (E.g.: PVP 25 MDX ES).

SILENCERS

The use of natural fibre sound absorbing material enclosed in special anodised aluminium casings has allowed creating this new range of silencers that considerably reduce noise made by air at the vacuum generator exhaust.

There are two versions with different lengths: the longer the length and the more will the noise be reduced.

Noise reduction: from -13 to -20 dB (A);

Working temperature: from -20 to +100 °C.

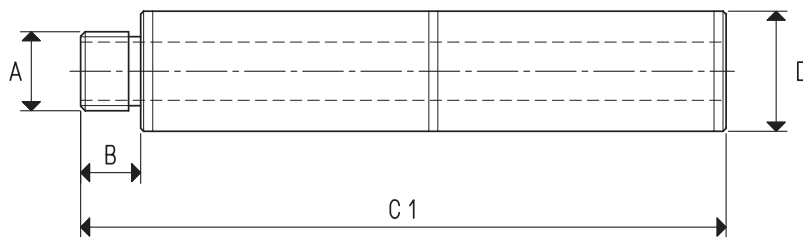
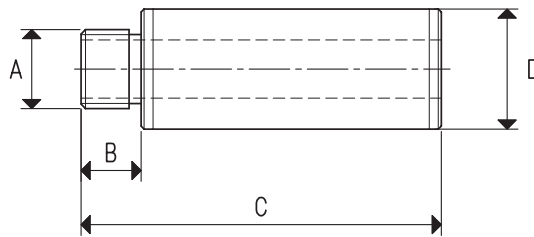

3D drawing available at www.vuototecnica.net

Art.	A Ø	B	C	C1	D Ø	Weight g
SSX 1/4"	G1/4"	10	60	--	20	20
SSX 3/8"	G3/8"	12	84	--	29	52
SSX 1/2"	G1/2"	14	106	--	35	96
SSX 3/4" R	G3/4"	14	106	--	35	100
SSX 3/4"	G3/4"	14	126	--	50	174
SSX 1"	G1"	14	146	--	55	240
SSX 1" 1/2	G1" 1/2	30	210	--	80	302
SSX 2"	G2"	30	230	--	90	372
2SSX 1/4"	G1/4"	10	--	108	20	40
2SSX 3/8"	G3/8"	12	--	154	29	104
2SSX 1/2"	G1/2"	14	--	196	35	192
2SSX 3/4"	G3/4"	14	--	236	50	348
2SSX 1"	G1"	14	--	276	55	480

MODULAR MULTI-STAGE VACUUM GENERATORS PVP 150 ÷ 600 MD

The special shape of these vacuum generators has allowed obtaining great suction capacities in very limited overall dimensions. The ejectors share the same features as the previous ones, but instead of being fixed directly onto the generator body, they are assembled onto modular frames. The superimposition of one or more frames determines the generator capacity. They are supplied by filtered compressed air with an optimal pressure of 6 bar (g), and they can create a maximum vacuum of 90%, with a suction capacity ranging from 200 to 750 cum/h, measured at the normal atmospheric pressure of 1013 mbar. They are fully made with anodised aluminium with disc valves and special compound seals. They are perfectly soundproofed which results in an extremely silent operation.



MODULAR MULTI-STAGE VACUUM GENERATORS PVP 150 MD and 300 MD

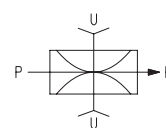
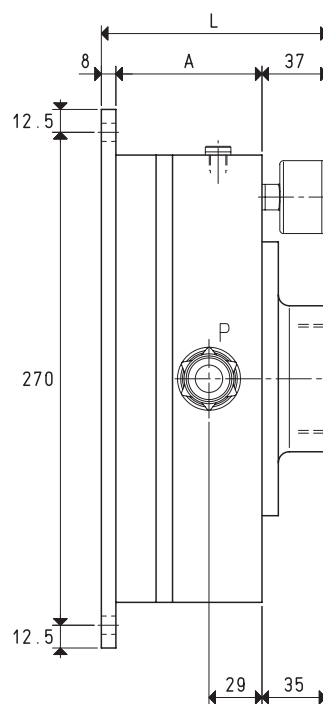
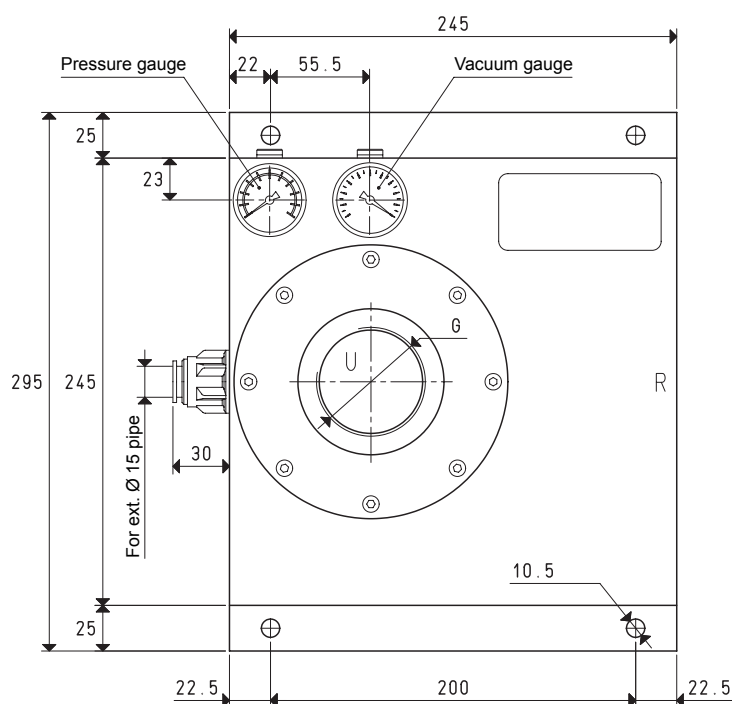

P=COMPRESSED AIR CONNECTION R=EXHAUST U=VACUUM CONNECTION

Art.				PVP 150 MD		PVP 300 MD	
Max. quantity of sucked air	cum/h	160	180	200	320	360	400
Max. vacuum level	-kPa	65	82	90	65	82	90
Final pressure	mbar abs.	350	180	100	350	180	100
Supply pressure	bar (g)	4	5	6	4	5	6
Air consumption	NI/s	12.1	14.2	16.0	23.2	27.8	32.0
Working temperature	°C			-20 / +80		-20 / +80	
Noise level	dB(A)			72		74	
Weight	Kg			7.8		8.8	
A				80		100	
G	Ø			G1" 1/2		G2"	
L				125		145	
Spare parts							
Sealing kit e disc valves	art.			00 KIT PVP 150 MD		00 KIT PVP 300 MD	
Vacuum gauge	art.			09 03 15		09 03 15	
Pressure gauge	art.			09 03 25		09 03 25	

Note: All the vacuum data indicated in the table are valid at the normal atmospheric pressure of 1013 mbar and are obtained with a constant supply pressure.

By adding the letter R to the article, the generator will be supplied with a built-in check valve (E.g.: PVP 300 MDR).

MODULAR MULTI-STAGE VACUUM GENERATORS PVP 150 MD and 300 MD

Air capacity (NI/s) at different vacuum levels (-Kpa)

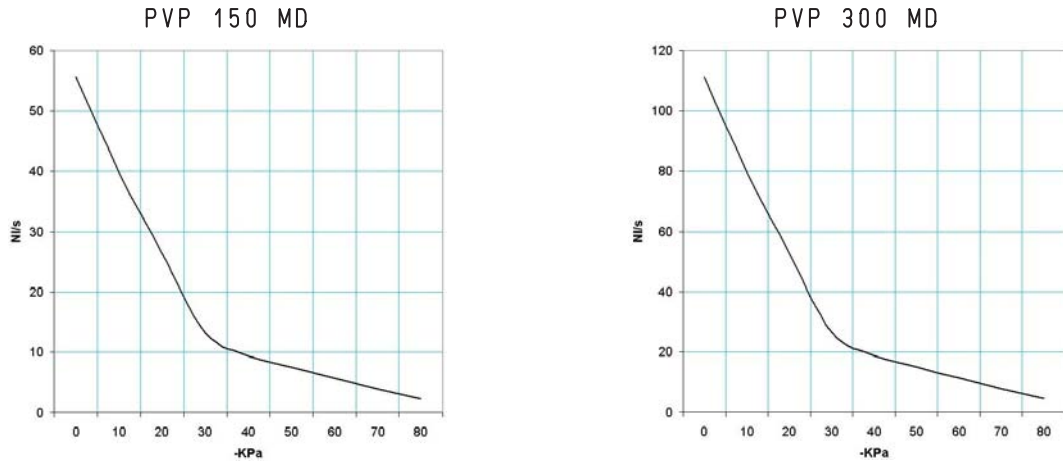

Generator art.	Supply press. bar (g)	Air consumption NI/s	Air capacity (NI/s) at different vacuum levels (-KPa)										Max. vacuum level -KPa
			0	10	20	30	40	50	60	70	80		
PVP 150 MD	6.0	16	55.55	39.68	26.45	13.22	9.44	7.55	5.68	3.97	2.27	90	
PVP 300 MD	6.0	32	111.11	79.36	52.91	26.45	19.89	15.11	11.36	7.94	4.54	90	

Evacuation time (ms/l=s/m³) at different vacuum levels (-Kpa)

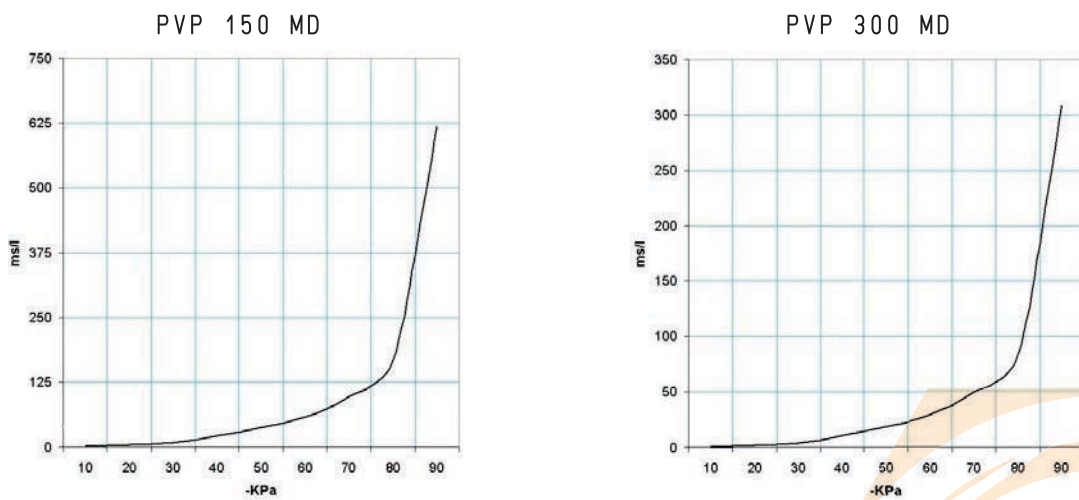

Generator art.	Supply press. bar (g)	Air consumption NI/s	Evacuation time (ms/l = s/m ³) at different vacuum levels (-KPa)									Max. vacuum level -KPa
			10	20	30	40	50	60	70	80	90	
PVP 150 MD	6.0	16	1.6	4.0	8.9	21.3	38.2	58.4	97.0	167.8	618	90
PVP 300 MD	6.0	32	0.8	2.0	4.4	10.6	19.1	29.2	48.5	83.9	386	90

MODULAR MULTI-STAGE VACUUM GENERATORS PVP 450 MD and 600 MD

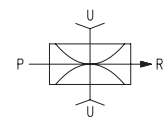
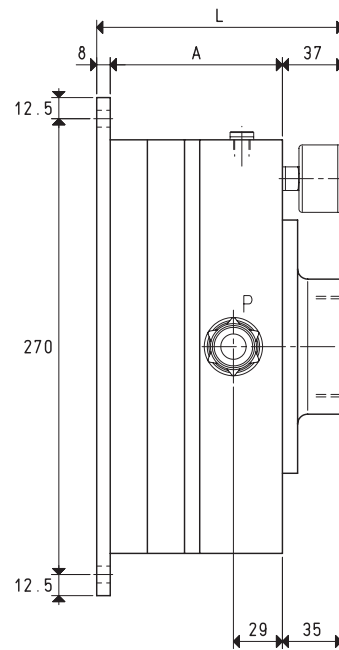
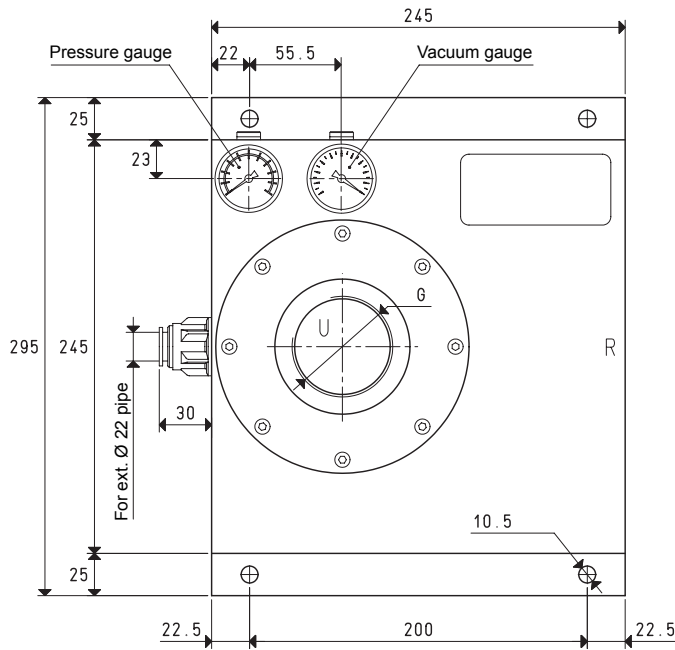

P=COMPRESSED AIR CONNECTION R=EXHAUST U=VACUUM CONNECTION

Art.				PVP 450 MD			PVP 600 MD
Max. quantity of sucked air	cum/h	490	530	580	640	700	750
Max. vacuum level	-KPa	65	82	90	65	82	90
Final pressure	mbar abs.	350	180	100	350	180	100
Supply pressure	bar (g)	4	5	6	4	5	6
Air consumption	NI/s	34.4	39.4	47.8	43.2	53.5	63.2
Working temperature	°C			-20 / +80			-20 / +80
Noise level	dB(A)			74			78
Weight	Kg			9.9			11.1
A				122			142
G	∅			G2" 1/2			G3"
L				167			187
Spare parts							
Sealing kit e disc valves	art.			00 KIT PVP 450 MD			00 KIT PVP 600 MD
Vacuum gauge	art.			09 03 15			09 03 15
Pressure gauge	art.			09 03 25			09 03 25

Note: All the vacuum data indicated in the table are valid at the normal atmospheric pressure of 1013 mbar and are obtained with a constant supply pressure.

By adding the letter R to the article, the generator will be supplied with a built-in check valve (E.g.: PVP 450 MDR).

3D drawing available at www.vuototecnica.net

MODULAR MULTI-STAGE VACUUM GENERATORS PVP 450 MD and 600 MD

Air capacity (NI/s) at different vacuum levels (-Kpa)

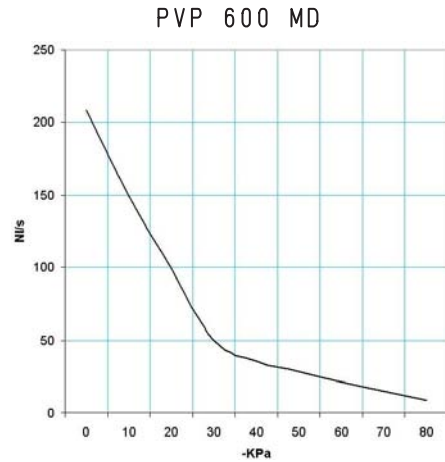
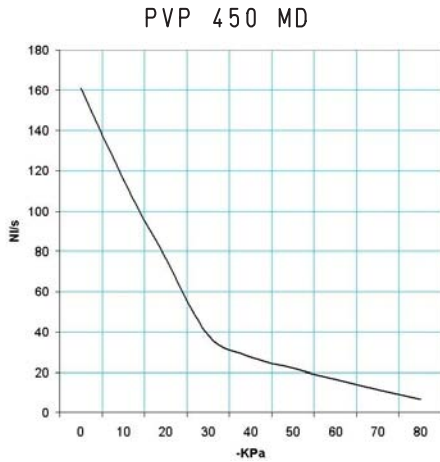

Generator art.	Supply press. bar (g)	Air consumption NI/s	Air capacity (NI/s) at different vacuum levels (-KPa)										Max. vacuum level -KPa
			0	10	20	30	40	50	60	70	80		
PVP 450 MD	6.0	47.8	161.11	115.07	76.71	38.35	27.39	21.91	16.48	11.52	6.58	90	
PVP 600 MD	6.0	63.2	208.33	148.80	99.20	49.60	35.43	28.34	21.31	14.90	8.51	90	

Evacuation time (ms/l=s/m³) at different vacuum levels (-Kpa)

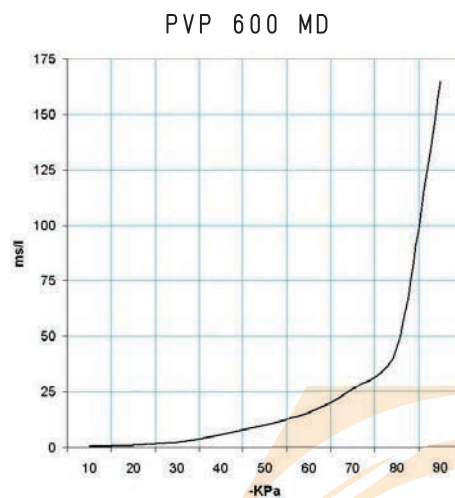
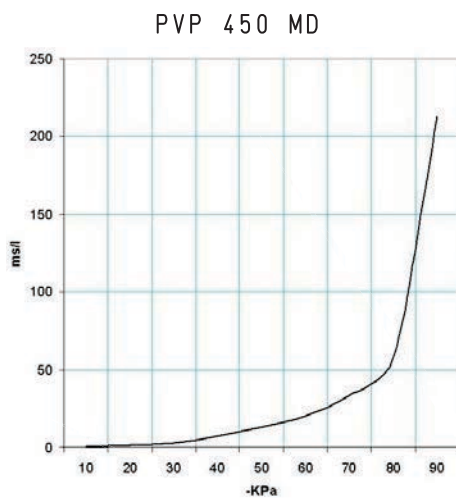

Generator art.	Supply press. bar (g)	Air consumption NI/s	Evacuation time (ms/l = s/m ³) at different vacuum levels (-KPa)									Max. vacuum level -KPa
			10	20	30	40	50	60	70	80	90	
PVP 450 MD	6.0	47.8	0.5	1.4	3.0	7.4	13.2	20.1	33.5	57.9	213	90
PVP 600 MD	6.0	63.2	0.4	1.0	2.4	5.7	10.2	15.6	25.9	44.8	165	90

ADJUSTABLE VACUUM GENERATORS CONEYOR

Working principle

The operation of these vacuum generators is based on the Venturi principle.

Unlike the previous ones, the ejector, apart from having a much larger flow diameter, is also adjustable.

This feature allows modifying the capacity and the vacuum level of the device, without intervening on the air supply pressure level.

Also the compressed air consumption is related to the actual performance of the vacuum generator.

Features

The special shape of these adjustable vacuum generators, as well as their straight-flow working principle allow sucking and transferring products of various nature with no interference, just like flow generators, only, unlike these, they allow overcoming much higher level differences.

They are suited for transferring powders, granulated products, sawdust, metal chips, dry or liquid food products, etc. They are also recommended for controlling vacuum cups in presence of large amounts of dust or liquids, as well as for sucking fumes, cooling mists, water and oil condensation, etc. The absence of moving parts allows for a continuous use without developing heat.

The noise level, which is quite high for this kind of equipment, can be considerably reduced with a silencer screwed on the exhaust connection.

They do not require electricity, therefore, they can even be used in work environments with hazardous environments where an ignition source would be dangerous.

Available in anodised aluminium and stainless steel.

Thanks to all these features, a good filtration of the compressed air supply will be sufficient to make these devices fully maintenance-free.

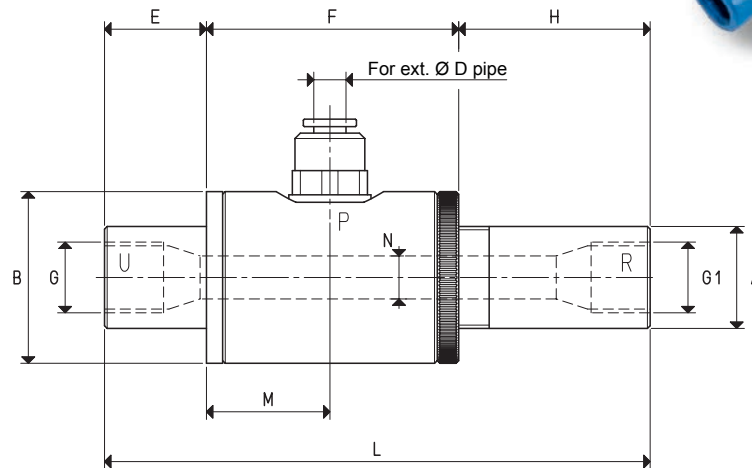

P=COMPRESSED AIR CONNECTION

R=EXHAUST

U=VACUUM CONNECTION

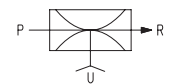

Art.		PVR 25	PVR 50
Max quantità di aria aspirata a 5 bar (g)	cum/h	13.0	36.0
Max. quantity of blown air at 6 bar (g)	cum/h	33.5	88.0
Max. vacuum level	-KPa	80	75
Final pressure	mbar abs.	200	250
Max pressione di alimentazione	bar (g)	6	6
Air consumption at 6 bar (g)	NI/s	6.1	15.5
Working temperature	°C	-20 / +80	-20 / +80
Noise level	dB(A)	92	98
Weight	g	150	280
A	Ø	19	26
B	Ø	32	38
D	Ø	6	8
E		19	35
F		47	54
G	Ø	G1/4"	G3/8"
G1	Ø	G1/4"	G1/2"
H		34	61
L		100	150
M		22	25
N	Ø	6	10

Note: All the vacuum data indicated in the table are valid at the normal atmospheric pressure of 1013 mbar and are obtained with a constant supply pressure.

By adding the letter I to the article, the generator will be supplied in the stainless steel version (E.g.: PVR 50 I).

3D drawing available at www.vuototecnica.net

ADJUSTABLE VACUUM GENERATORS CONEYOR PVR 25 and PVR 50

Quantity of sucked air (cum/h) at different supply pressures (bar)

PVR 25

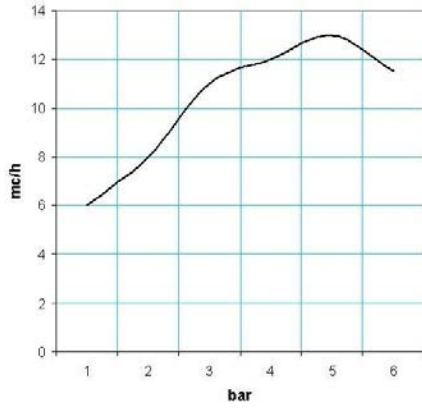

PVR 50

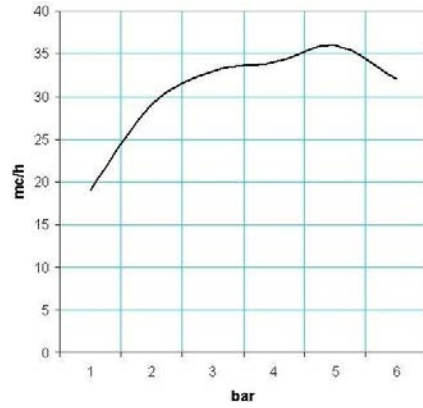

Quantity of blown air (cum/h) at different supply pressures (bar)

PVR 25

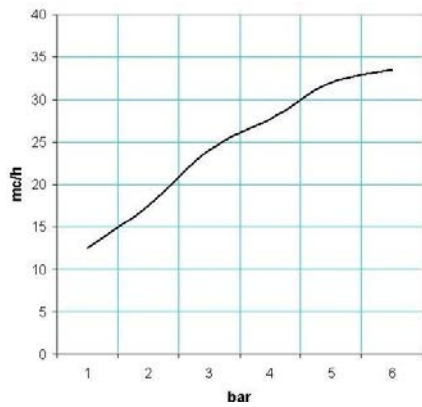

PVR 50

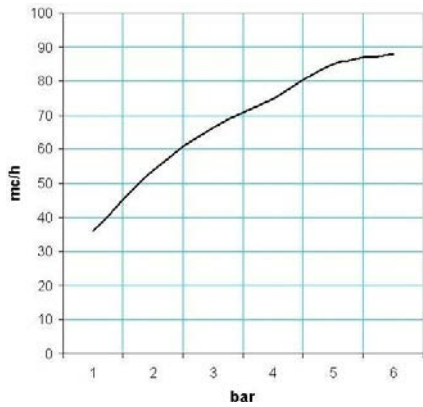

Vacuum level (-Kpa) at different supply pressures (bar)

PVR 25

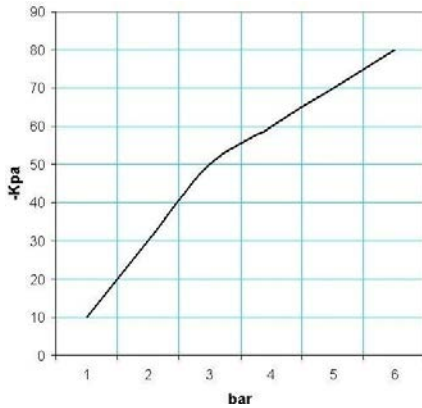

PVR 50

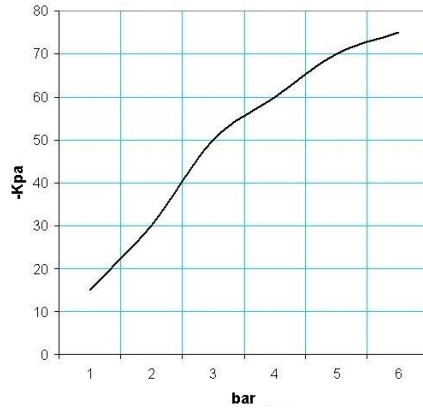

Air consumption (NI/s) at different supply pressures (bar)

PVR 25

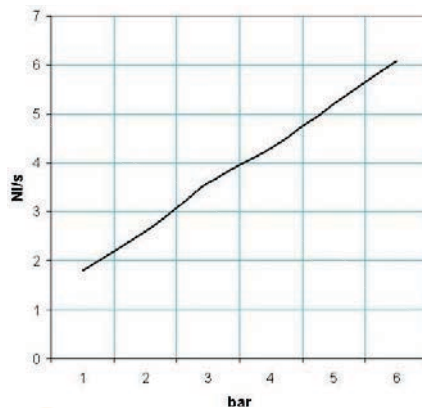

PVR 50

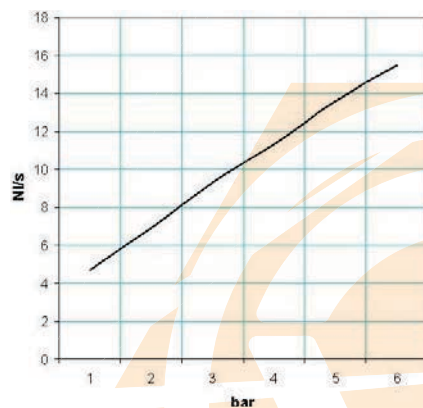

ADJUSTABLE VACUUM GENERATORS CONEYOR PVR 100 and PVR 200

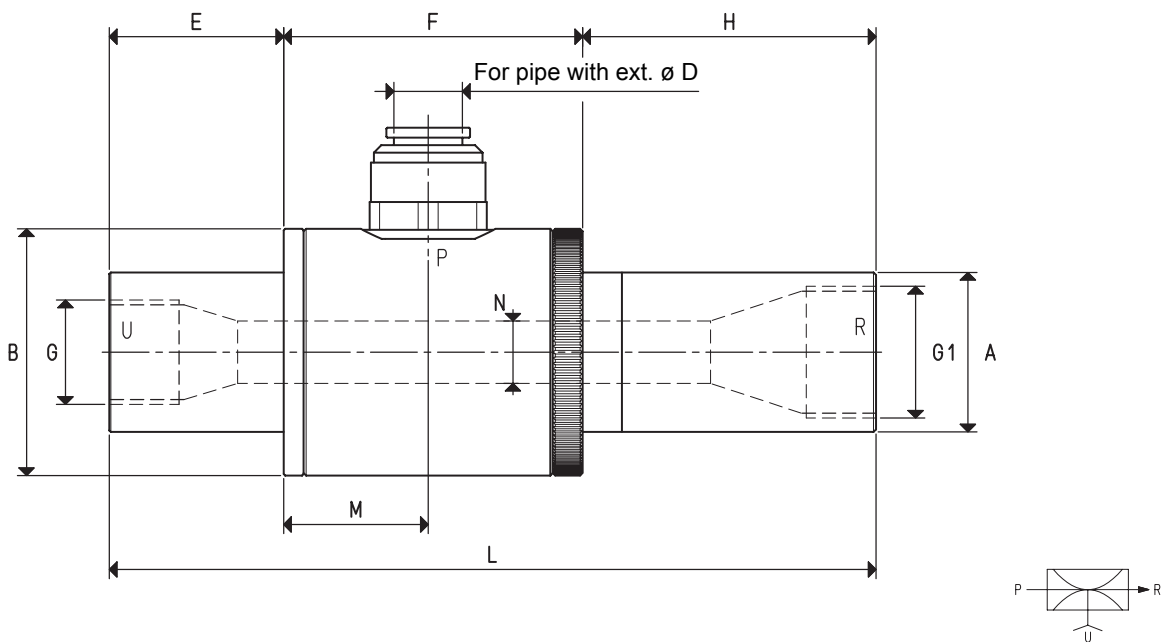

P=COMPRESSED AIR CONNECTION R=EXHAUST U=VACUUM CONNECTION

Art.		PVR 100	PVR 200
Max quantità di aria aspirata a 5 bar (g)	cum/h	50	72
Max. quantity of blown air at 6 bar (g)	cum/h	129	177
Max. vacuum level	-KPa	75	70
Final pressure	mbar abs.	250	300
Max pressione di alimentazione	bar (g)	6	6
Air consumption at 6 bar (g)	NI/s	22.7	28.3
Working temperature	°C	-20 / +80	-20 / +80
Noise level	dB(A)	100	104
Weight	g	430	550
A	∅	32	38
B	∅	50	57
D	∅	10	12
E		35	35
F		60	60
G	∅	G1/2"	G3/4"
G1	∅	G3/4"	G1"
H		55	77
L		150	172
M		28	28
N	∅	12.5	16.0

Note: All the vacuum data indicated in the table are valid at the normal atmospheric pressure of 1013 mbar and are obtained with a constant supply pressure.

By adding the letter I to the article, the generator will be supplied in the stainless steel version (E.g.: PVR 100 I).

3D drawing available at www.vuototecnica.net

ADJUSTABLE VACUUM GENERATORS CONEYOR, PVR 100 and PVR 200

Quantity of sucked air (cum/h) at different supply pressures (bar)

PVR 100

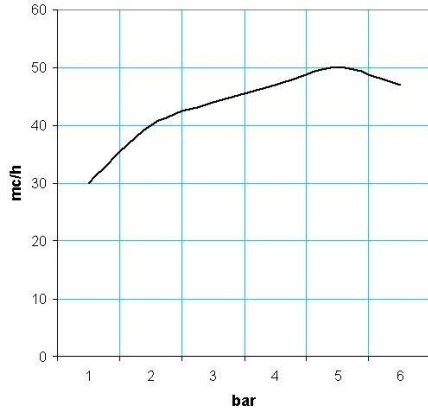

PVR 200

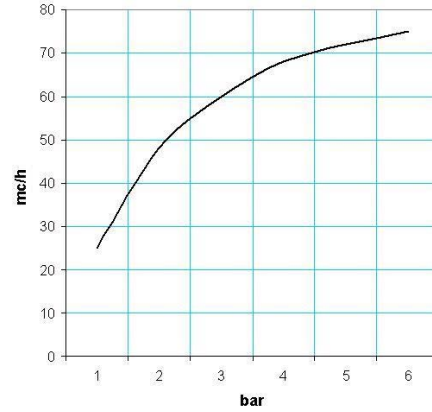

Quantity of blown air (cum/h) at different supply pressures (bar)

PVR 100

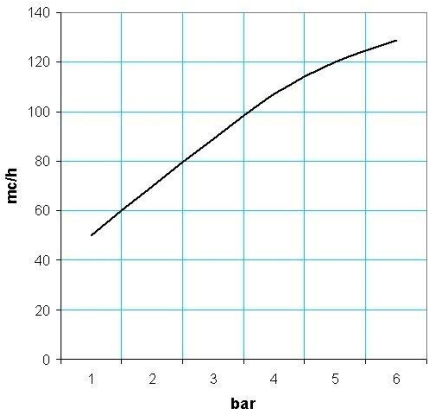

PVR 200

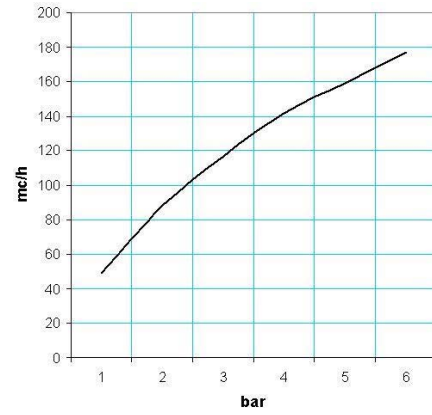

Vacuum level (-Kpa) at different supply pressures (bar)

PVR 100

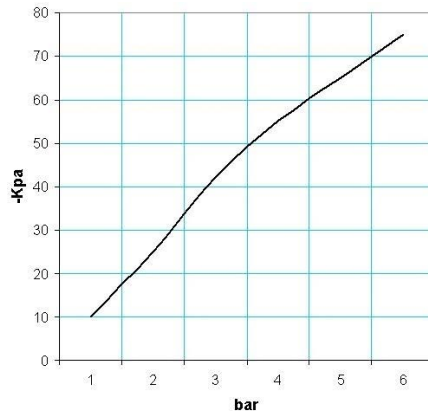

PVR 200

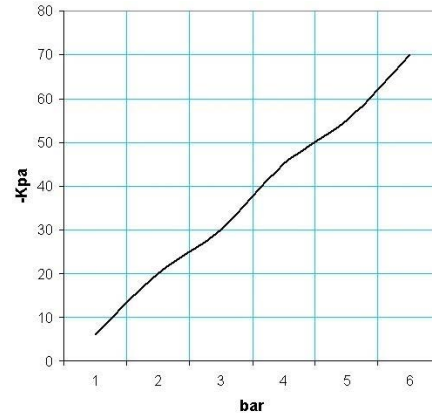

Air consumption (Nl/s) at different supply pressures (bar)

PVR 100

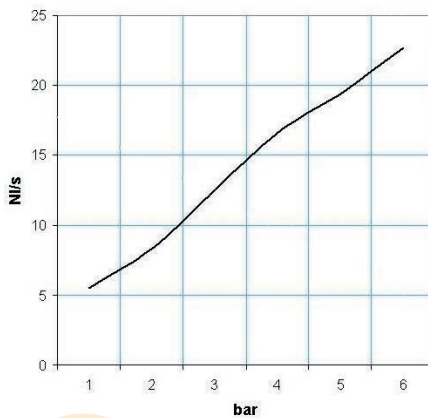

PVR 200

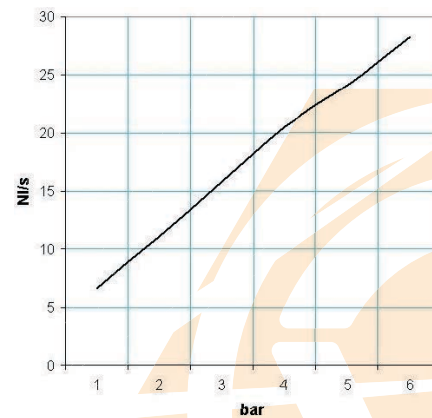

ACCESSORIES FOR ADJUSTABLE VACUUM GENERATORS CONVEYOR

The noise level of adjustable vacuum generators Conveyor is always quite high, but it can be considerably reduced with a silencer screwed on the exhaust connection. Upon request, silencers of the SSX range, which are suitable for any kind of Conveyor vacuum generator, can be supplied.

The table below shows the codes of the silencers associated with the various vacuum generators.

PVR 25 with exhaust silencer SSX 1/4" and vacuum cup 08 53 35 S



PVR 50 with exhaust silencer 2SSX 1/2"



PVR 100 with exhaust silencer SSX 3/4"



Art.	Silencer	Noise reduction dB(A)	Silencer	Noise reduction dB(A)
	art.		art.	
PVR 25	SSX 1/4"	-13	2SSX 1/4"	-20
PVR 50	SSX 1/2"	-13	2SSX 1/2"	-20
PVR 100	SSX 3/4"	-13	2SSX 3/4"	-20
PVR 200	SSX 1"	-13	2SSX 1"	-20

FLOW GENERATOR VACUUM JET



Working principle

The compressed air supply blown into a ring chamber concentric to the device, flows at a very high speed towards the centre of the main pipe, thus forming a cyclonic effect. The latter creates a vacuum inside the device and leads a great volume of air towards its outlet. Therefore, a variation of the air supply pressure will modify the vacuum level and the amount of sucked air.

Features

The special shape of these adjustable vacuum generators, as well as their straight-flow working principle allow sucking and transferring products of various nature with no interference. In fact, Vacuum Jet flow generators are suited for transferring powders, granulated products, sawdust, metal chips, dry or liquid food products, etc. They are also recommended for controlling vacuum cups in presence of large amounts of dust or liquids, as well as for sucking fumes, cooling mists, water and oil condensation, etc. The absence of moving parts allows for a continuous use without developing heat.

Available in anodised aluminium and stainless steel.

Thanks to all these features, a good filtration of the compressed air supply will be sufficient to make these devices fully maintenance-free.

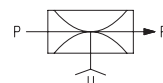
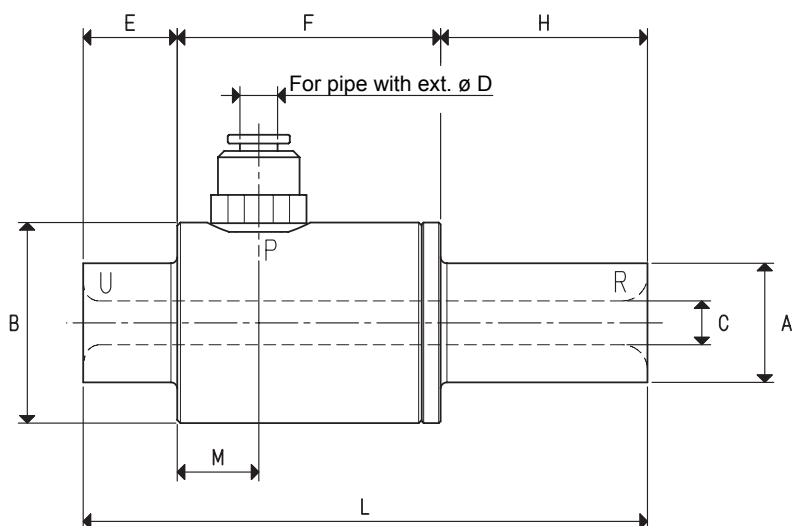

P=COMPRESSED AIR CONNECTION

R=EXHAUST

U=VACUUM CONNECTION

Art.		CX 7	CX 10
Max. quantity of sucked air at 6 bar (g)	cum/h	12.0	28.0
Max. quantity of blown air at 6 bar (g)	cum/h	17.6	51.4
Max. vacuum level	-KPa	15	22
Final pressure	mbar abs.	850	780
Max pressione di alimentazione	bar (g)	6	6
Air consumption at 6 bar (g)	NI/s	1.5	6.5
Working temperature	°C	-20 / +80	-20 / +80
Noise level	dB(A)	75	84
Weight	g	110	104
A	∅	19	19
B	∅	32	32
C	∅	7	10
D	∅	6	6
E		15	15
F		42	42
H		33	33
L		90	90
M		13	13

Note: All the vacuum data indicated in the table are valid at the normal atmospheric pressure of 1013 mbar and are obtained with a constant supply pressure.

By adding the letter I to the article, the generator will be supplied in the stainless steel version (E.g.: CX 10 I).

Conversion ratio: inch = $\frac{\text{mm}}{25.4}$; pounds = $\frac{\text{g}}{453.6} = \frac{\text{Kg}}{0.4536}$

GAS-NPT thread adapters available at page 1.117

FLOW GENERATOR VACUUM JET, CX 7 and CX 10

Quantity of sucked air (cum/h) at different supply pressures (bar)

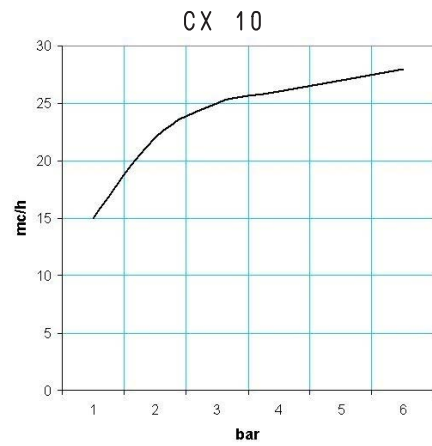
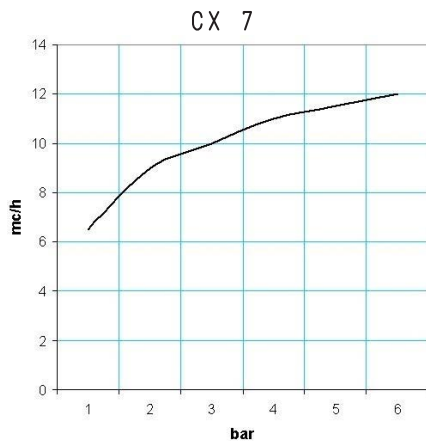

Quantity of blown air (cum/h) at different supply pressures (bar)

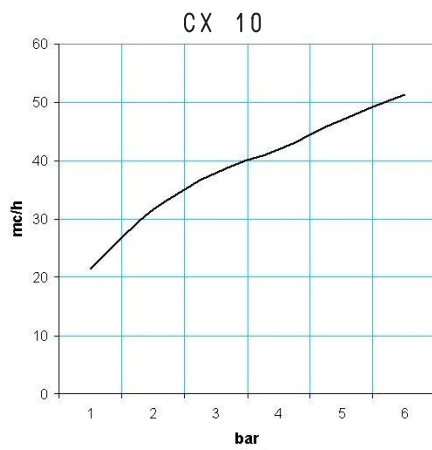
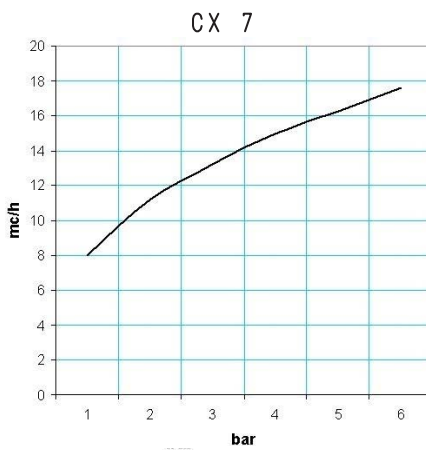

Vacuum level (-Kpa) at different supply pressures (bar)

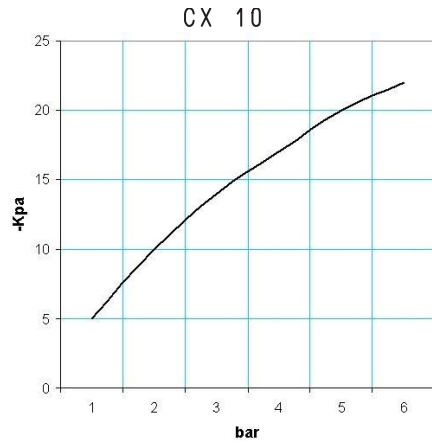
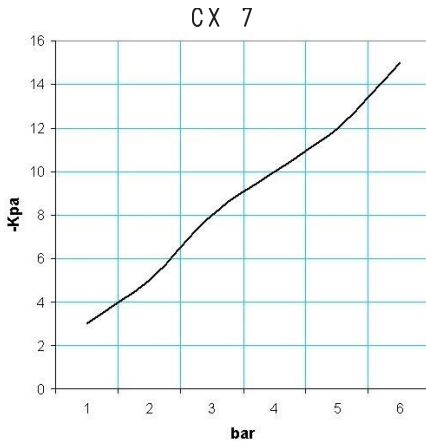

Air consumption (NI/s) at different supply pressures (bar)

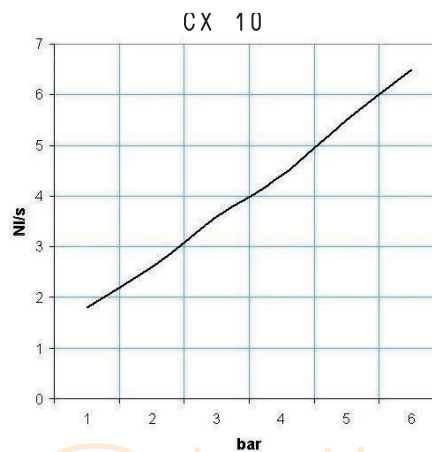
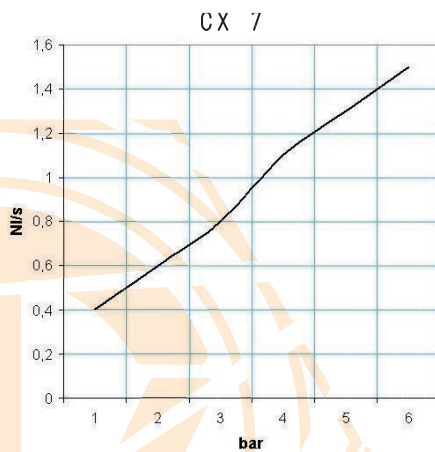

FLOW GENERATOR VACUUM JET, CX 13 and CX 19

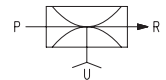
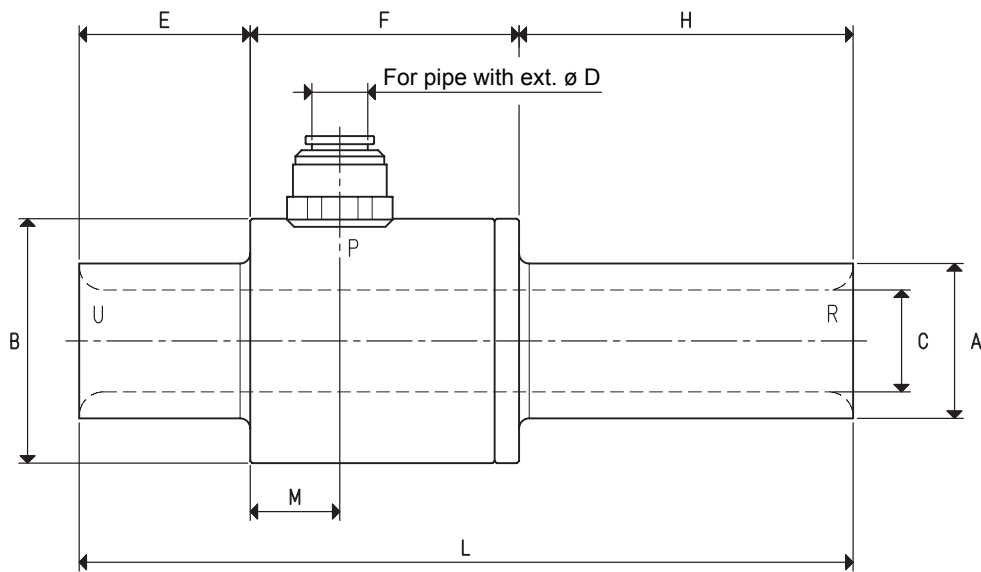

P=COMPRESSED AIR CONNECTION R=EXHAUST U=VACUUM CONNECTION

Art.		CX 13	CX 19
Max. quantity of sucked air at 6 bar (g)	cum/h	50.0	92.0
Max. quantity of blown air at 6 bar (g)	cum/h	73.7	134.0
Max. vacuum level	-KPa	18	16
Final pressure	mbar abs.	820	840
Max pressione di alimentazione	bar (g)	6	6
Air consumption at 6 bar (g)	NI/s	6.6	11.6
Working temperature	°C	-20 / +80	-20 / +80
Noise level	dB(A)	88	92
Weight	g	280	500
A	∅	25	32
B	∅	45	54
C	∅	13	19
D	∅	8	10
E		30	43
F		55	65
H		55	82
L		140	190
M		18	22

Note: All the vacuum data indicated in the table are valid at the normal atmospheric pressure of 1013 mbar and are obtained with a constant supply pressure.

By adding the letter I to the article, the generator will be supplied in the stainless steel version (E.g.: CX 13 I).

Conversion ratio: inch = $\frac{\text{mm}}{25.4}$; pounds = $\frac{\text{g}}{453.6}$ = $\frac{\text{Kg}}{0.4536}$

GAS-NPT thread adapters available at page 1.117

FLOW GENERATOR VACUUM JET, CX 13 and CX 19

Quantity of sucked air (cum/h) at different supply pressures (bar)

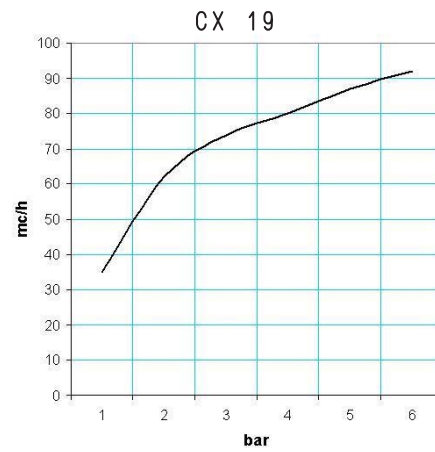
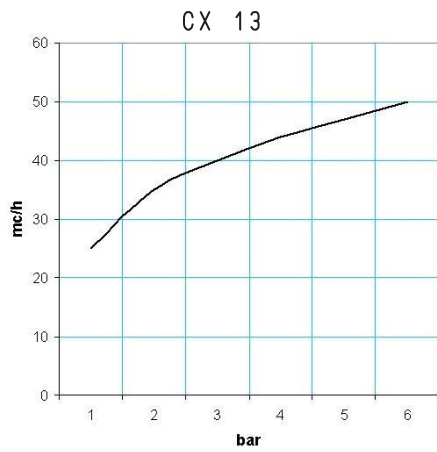

Quantity of blown air (cum/h) at different supply pressures (bar)

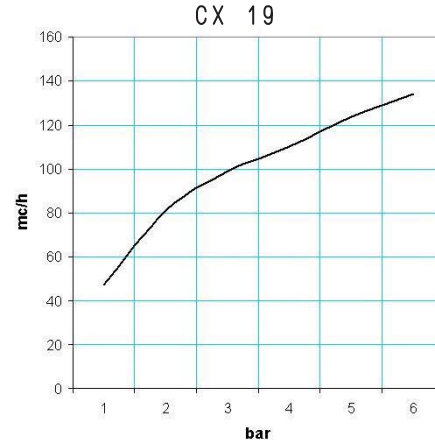
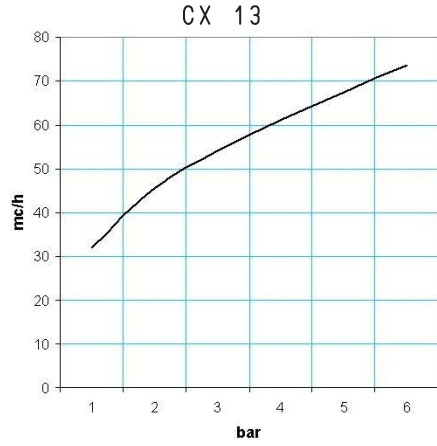

Vacuum level (-Kpa) at different supply pressures (bar)

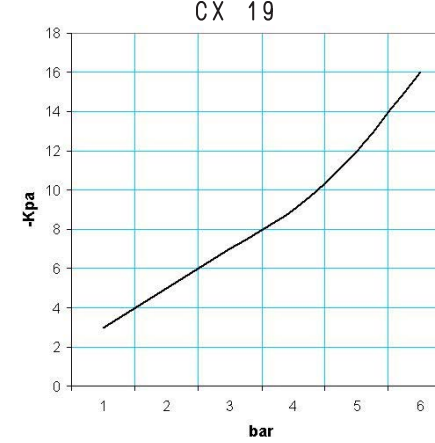
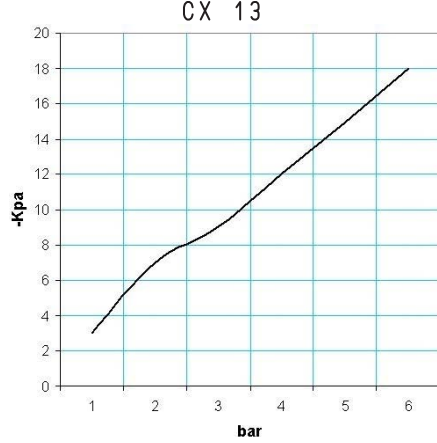

Air consumption (NI/s) at different supply pressures (bar)

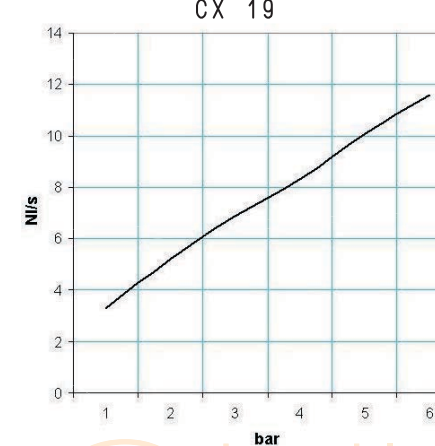
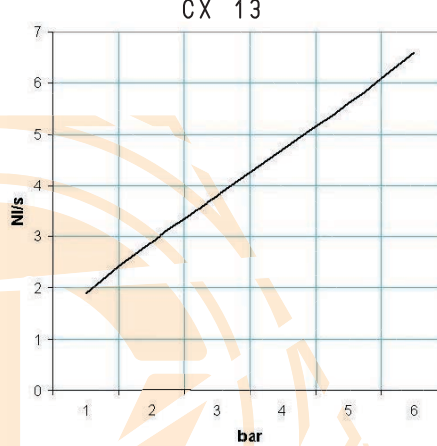

FLOW GENERATOR VACUUM JET, CX 25, CX 38 and CX 50

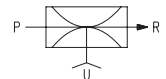
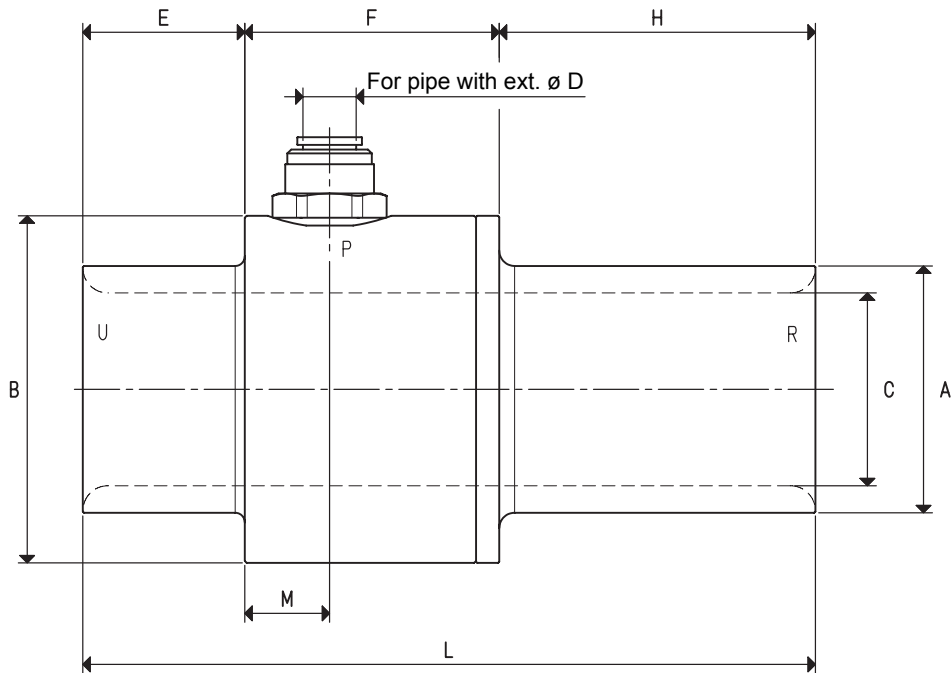

P=COMPRESSED AIR CONNECTION R=EXHAUST U=VACUUM CONNECTION

Art.		CX 25	CX 38	CX 50
Max. quantity of sucked air at 6 bar (g)	cum/h	150	310	405
Max. quantity of blown air at 6 bar (g)	cum/h	210	400	525
Max. vacuum level	-KPa	13	10	8
Final pressure	mbar abs.	870	900	920
Max. supply pressure	bar (g)	6.0	6.0	6.0
Air consumption at 6 bar (g)	NI/s	16.6	25.0	33.3
Working temperature	°C	-20 / +80	-20 / +80	-20 / +80
Noise level	dB(A)	100	103	103
Weight	g	560	800	1090
A	∅	38	51	64
B	∅	60	75	90
C	∅	25	38	50
D	∅	10	12	16
E		42	42	42
F		66	66	66
H		82	82	82
L		190	190	190
M		22	22	22

Note: All the vacuum data indicated in the table are valid at the normal atmospheric pressure of 1013 mbar and are obtained with a constant supply pressure.

By adding the letter I to the article, the generator will be supplied in the stainless steel version (E.g.: CX 38 I).

Conversion ratio: inch = $\frac{\text{mm}}{25.4}$; pounds = $\frac{\text{g}}{453.6} = \frac{\text{Kg}}{0.4536}$

GAS-NPT thread adapters available at page 1.117

FLOW GENERATOR VACUUM JET, CX 25, CX 38 and CX 50

Quantity of sucked air (cum/h) at different supply pressures (bar)

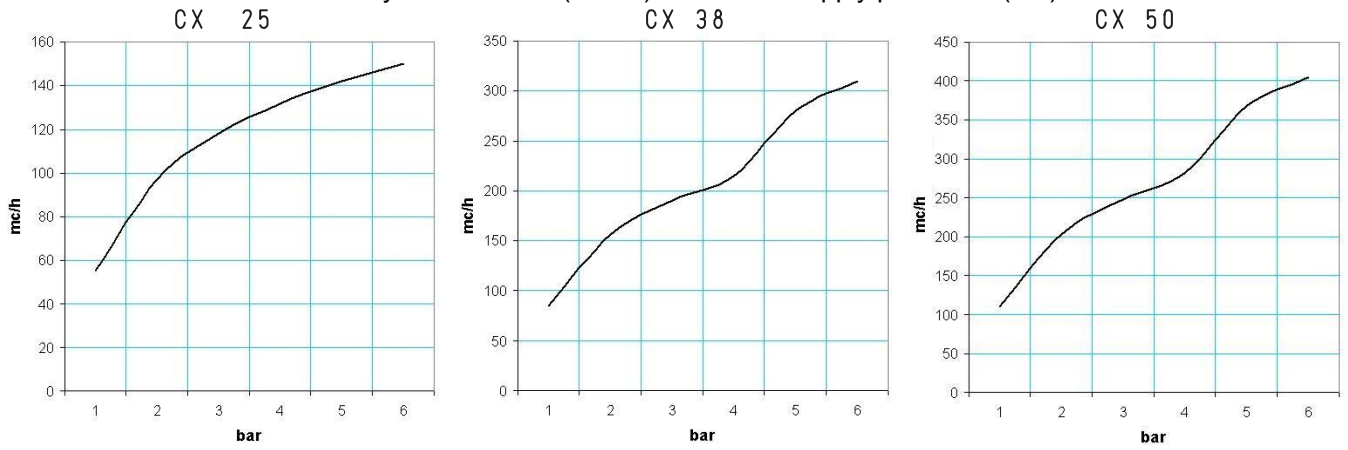

Quantity of blown air (cum/h) at different supply pressures (bar)

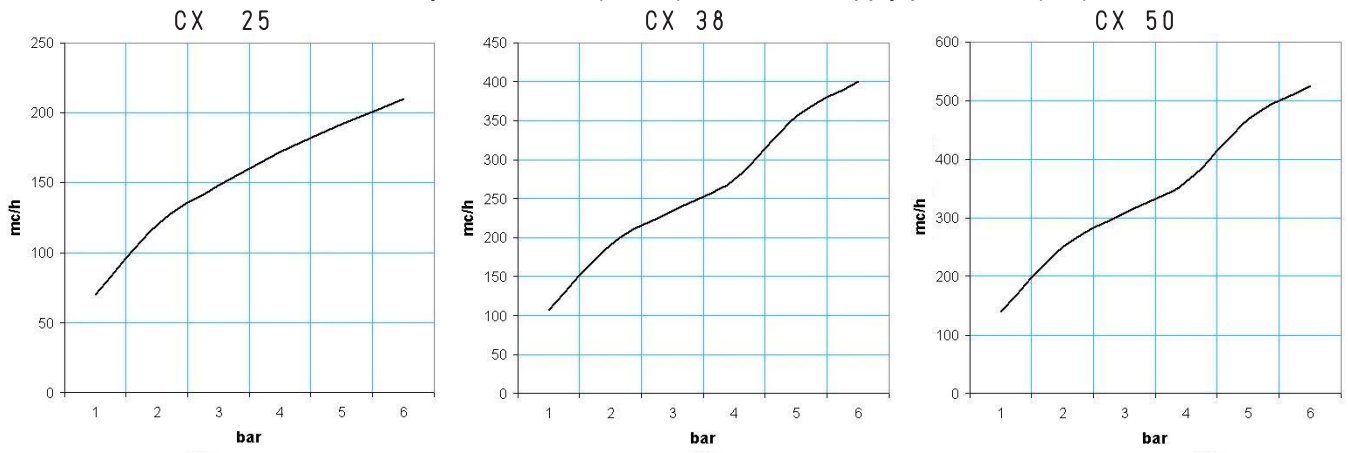

Vacuum level (-Kpa) at different supply pressures (bar)

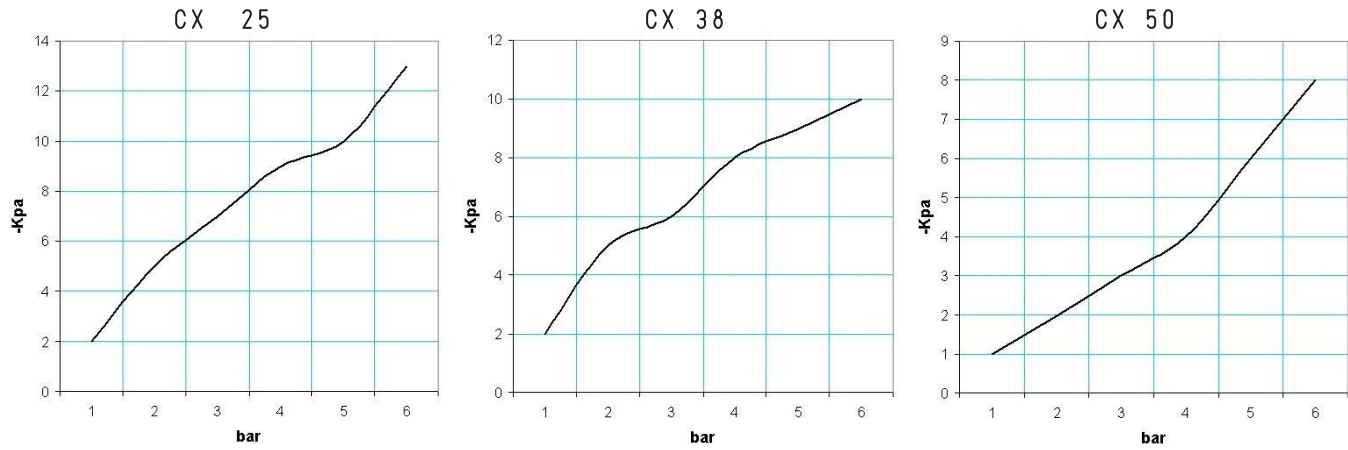

Air consumption (NI/s) at different supply pressures (bar)

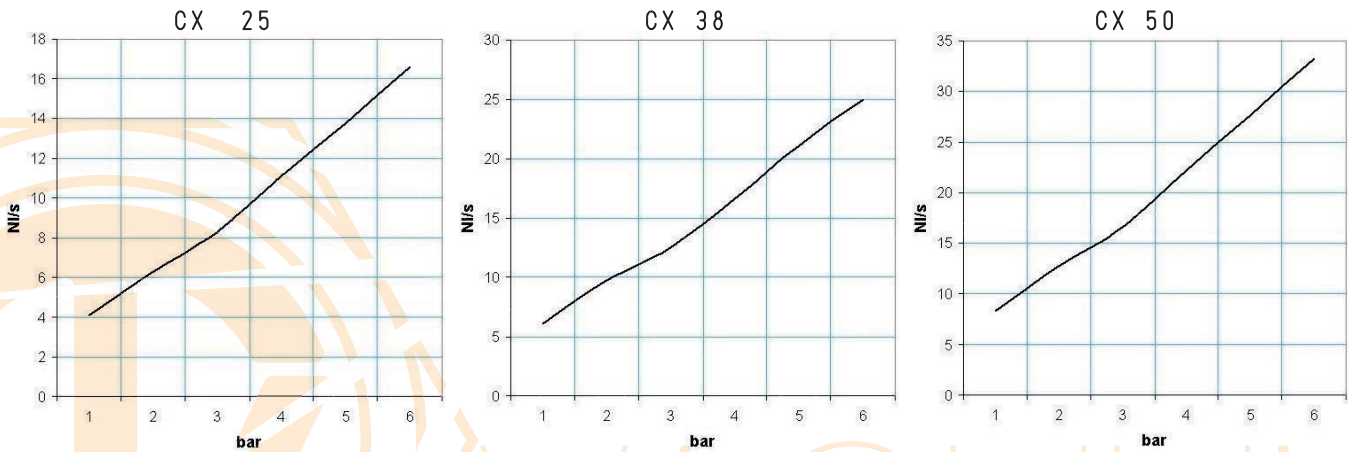

MINI PNEUMATIC PUMPSETS DOP 06 and DOP 10

Mini pneumatic pumpsets are independent vacuum units, fed exclusively by compressed air and featuring very small sizes. They are composed of:

- A small welded sheet steel tank.
 - A compressed air-operated vacuum generator.
 - A pneumatic vacuum switch for adjusting the vacuum level.
 - A vacuum gauge for a direct reading of the vacuum level.
 - A manual valve for vacuum interception.
 - A suction filtre with an FC paper cartridge.
 - A pressure adjuster equipped with filtre.
 - A pneumatic activation valve for the vacuum generator supply.
 - A sleeve valve for compressed air interception.
 - for compressed air interception for draining condensation from the tank.
- the vacuum level in the tank, previously set with the vacuum switch, is automatically maintained.

Mini pneumatic pumpsets are suited for equipping small fixed and mobile working units that require vacuum, such as:

- Trolleys with vacuum cups for fixing and transporting glass and crystals.
- Vacuum clamping systems for ski maintenance, to drill or pantograph marble, to polish pewter, copper or silver objects, etc.
- Tackles with cups for lifting television sets and other household appliances, for the insertion of glass in the window fittings, for feeding sheet metal to presses, etc.

Mini pneumatic pumpsets require no electricity, only compressed air at a 4 ÷ 6 bar (g) pressure. For this feature they are recommended in hazardous environments where an ignition source would be dangerous.

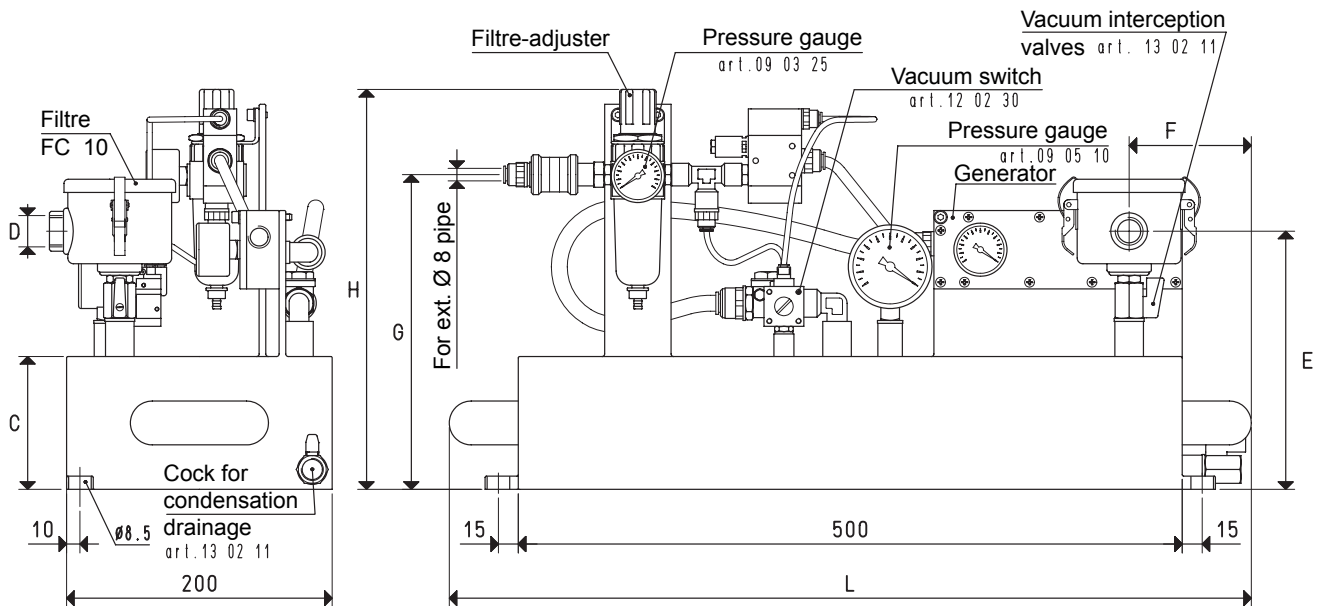

Art.	Tank	Generator	Pneumatic device	C	D	E	F	G	H	L	Weight
	Litres	art.	art.				Ø				Kg
DOP 06 PVP 12 MX	6	PVP 12 MX	DOP 06 90	60	G3/8"	150	95	180	260	620	12.7
DOP 06 PVP 25 MX	6	PVP 25 MX	DOP 06 90	60	G3/8"	150	95	180	260	620	13.0
DOP 10 PVP 12 MX	10	PVP 12 MX	DOP 06 90	100	G3/8"	210	95	240	300	620	12.9
DOP 10 PVP 25 MX	10	PVP 25 MX	DOP 06 90	100	G3/8"	210	95	240	300	620	13.2

Conversion ratio: inch = $\frac{mm}{25.4}$; pounds = $\frac{g}{453.6} = \frac{Kg}{0.4536}$

GAS-NPT thread adapters available at page 1.117

MINI PNEUMATIC PUMPSETS DOP 20

The distinctive feature of this mini pumpset, apart from the tank volume, is the installed vacuum generator.

The vacuum generator of the PVP... MDX ES range, in fact, is equipped with an energy saving device which allows automatically maintaining the preset vacuum level inside the tank. The other accessories, except for the vacuum switch and the pneumatic activation valve for the vacuum generator supply, are the same as those installed on DOP 06 and DOP 10. They are used as the previously described mini pneumatic pumpsets.

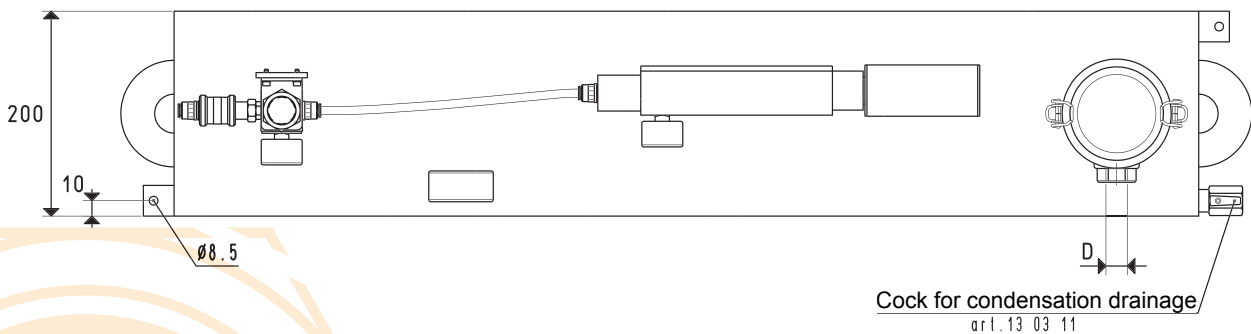
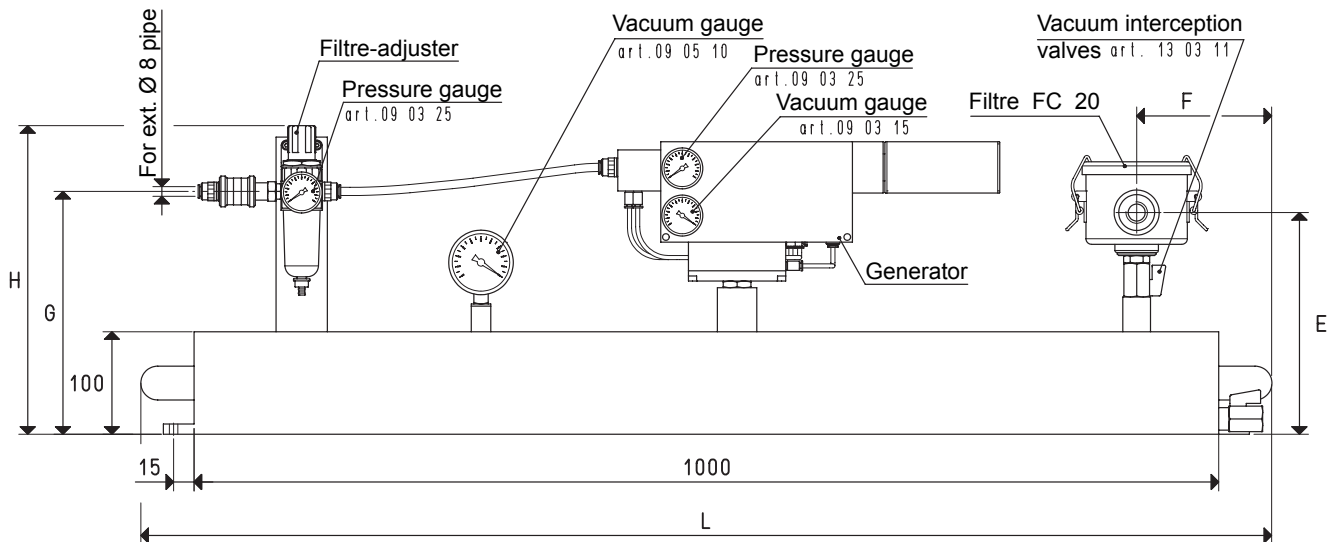
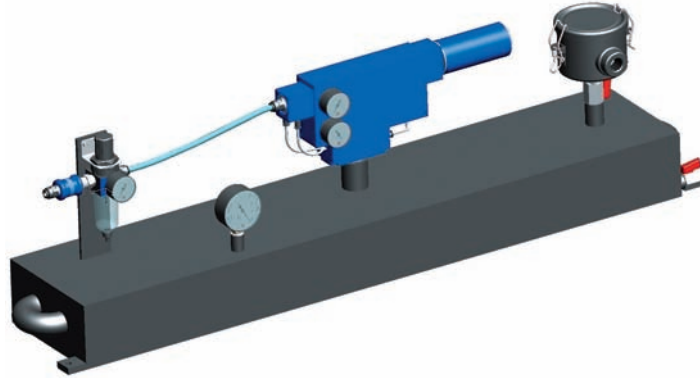

Art.	Tank Litres	Generator art.	Pneumatic device art.	D Ø	E	F	G	H	L	Weight Kg
DOP 20 PVP 25 MDX	20	PVP 25 MDX ES	DOP 20 90	G1/2"	225	135	270	340	1110	20.6
DOP 20 PVP 35 MDX	20	PVP 35 MDX ES	DOP 20 90	G1/2"	225	135	270	340	1110	20.7

PNEUMATIC PUMPSETS DOP 25, DOP 50 and DOP 100

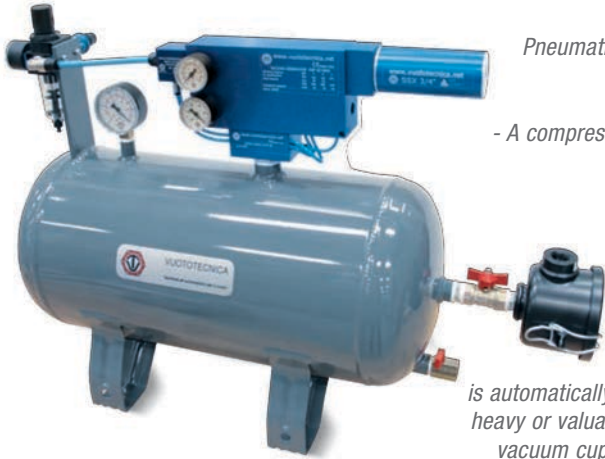

Pneumatic pumpsets are independent vacuum units fed exclusively by compressed air.

They are composed of:

- A welded sheet steel tank.
- A compressed air-operated vacuum generator PVP ... MDX ES, equipped with an energy saving device.
- A vacuum gauge for a direct reading of the vacuum level.
- A manual valve for vacuum interception.
- A suction filtre with an FC paper cartridge.
- A pressure adjuster equipped with filtre.
- A sleeve valve for compressed air interception.
- A cock for draining condensation from the tank.

the vacuum level in the tank, previously set with the vacuum switch, is automatically maintained. Pneumatic pumpsets are normally used for handling particularly heavy or valuable loads, since even in case of a sudden power supply failure, they allow the vacuum cups to maintain the grip for a certain amount of time (which varies according to the tank capacity). They are recommended for connecting several applications to centralise the vacuum. In any case, the use of the pumpset offers a great advantage under an energy-saving point of view, since the generator operates only when vacuum is required by the application.

Pneumatic pumpsets require no electricity, only compressed air at a 4 ÷ 6 bar (g) pressure.

For this feature, they are recommended in hazardous environments where an ignition source would be dangerous.

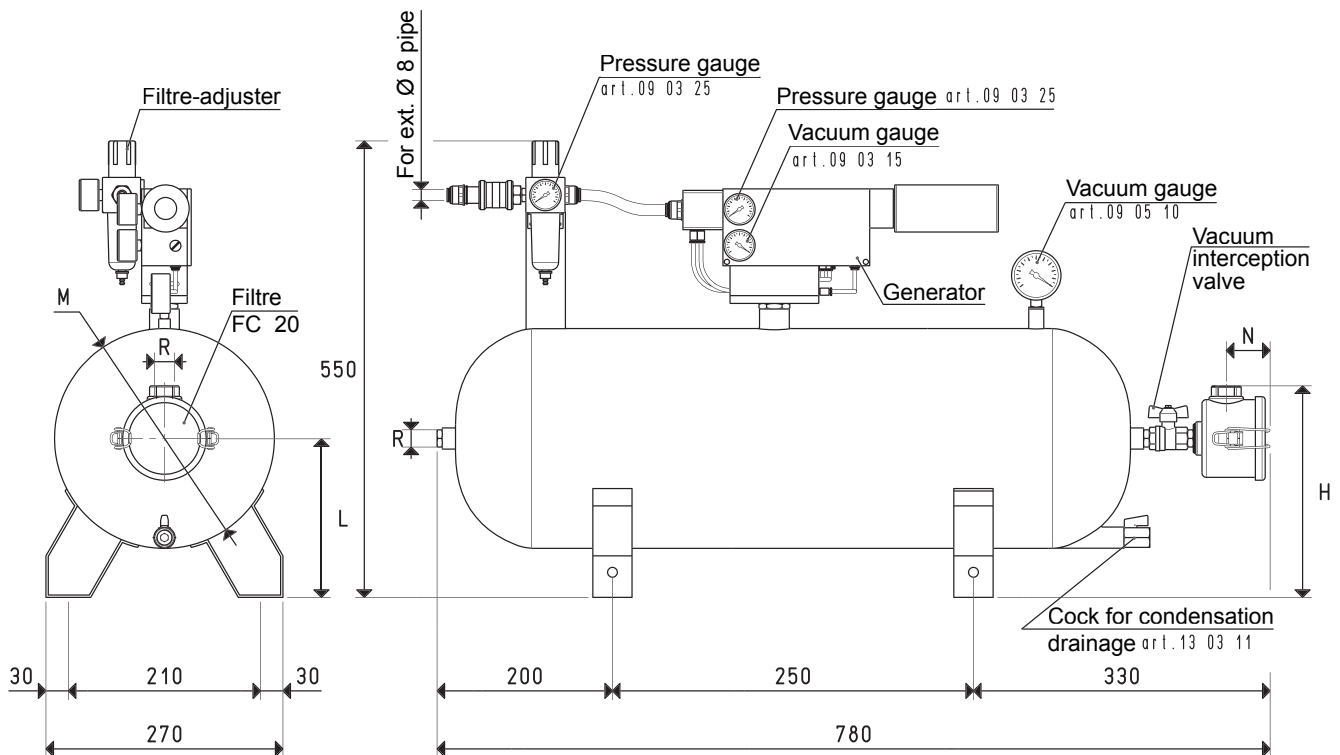

Art.	Tank	Generator	Pneumatic device	H	L	M	N	R	Weight
	Litres	art.	art.			∅		∅	Kg
DOP 25 PVP 25 MDX	25	PVP 25 MDX ES	DOP 20 90	225	185	240	51	G1/2"	15.9
DOP 25 PVP 35 MDX	25	PVP 35 MDX ES	DOP 20 90	225	185	240	51	G1/2"	16.0

PNEUMATIC PUMPSETS DOP 50

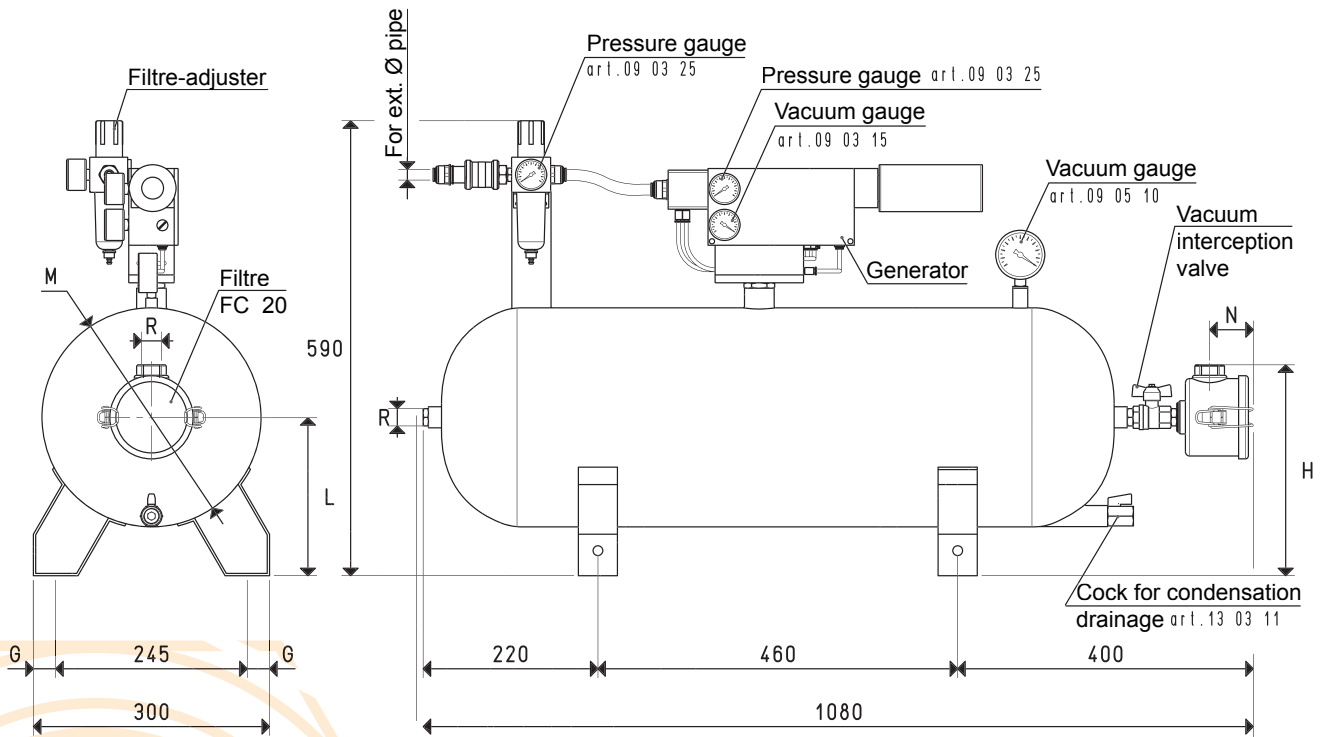
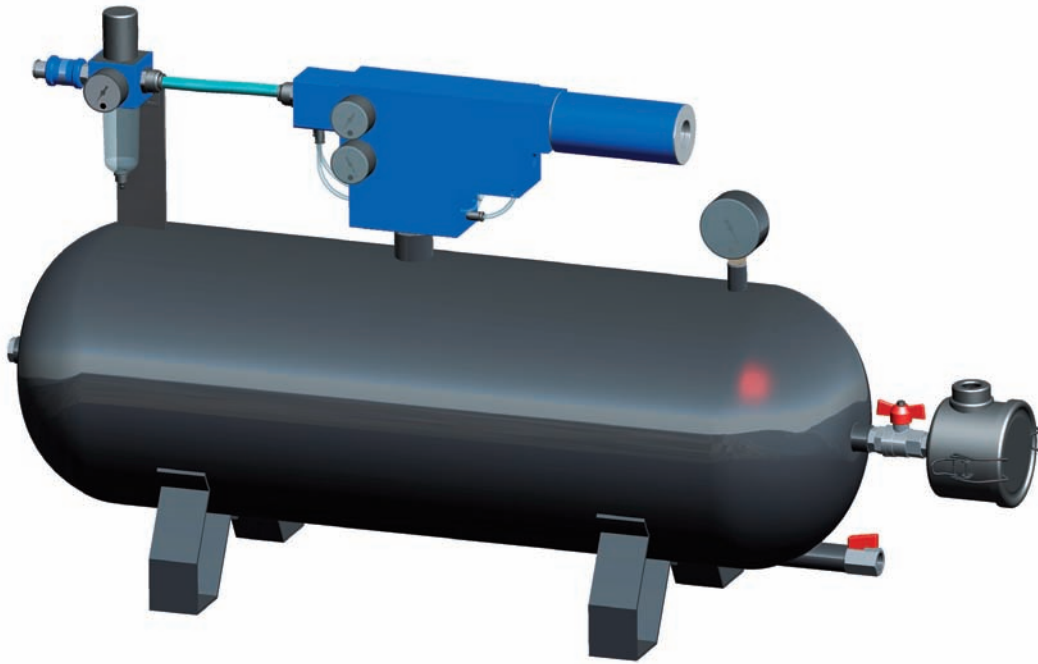

3D drawing available at www.vuototecnica.net

Art.	Tank	Generator	Pneumatic device	G	H	L	M	N	R	Hose ext. Ø	Weight
Litres	Litres	art.	art.				Ø		Ø	Ø	Kg
DOP 50 PVP 50 MDX	50	PVP 50 MDX ES	DOP 20 90	27.5	245	205	280	51	G1/2"	8	18.9
DOP 50 PVP 60 MDX	50	PVP 60 MDX ES	DOP 50 90	27.5	245	205	280	51	G1/2"	12	19.7

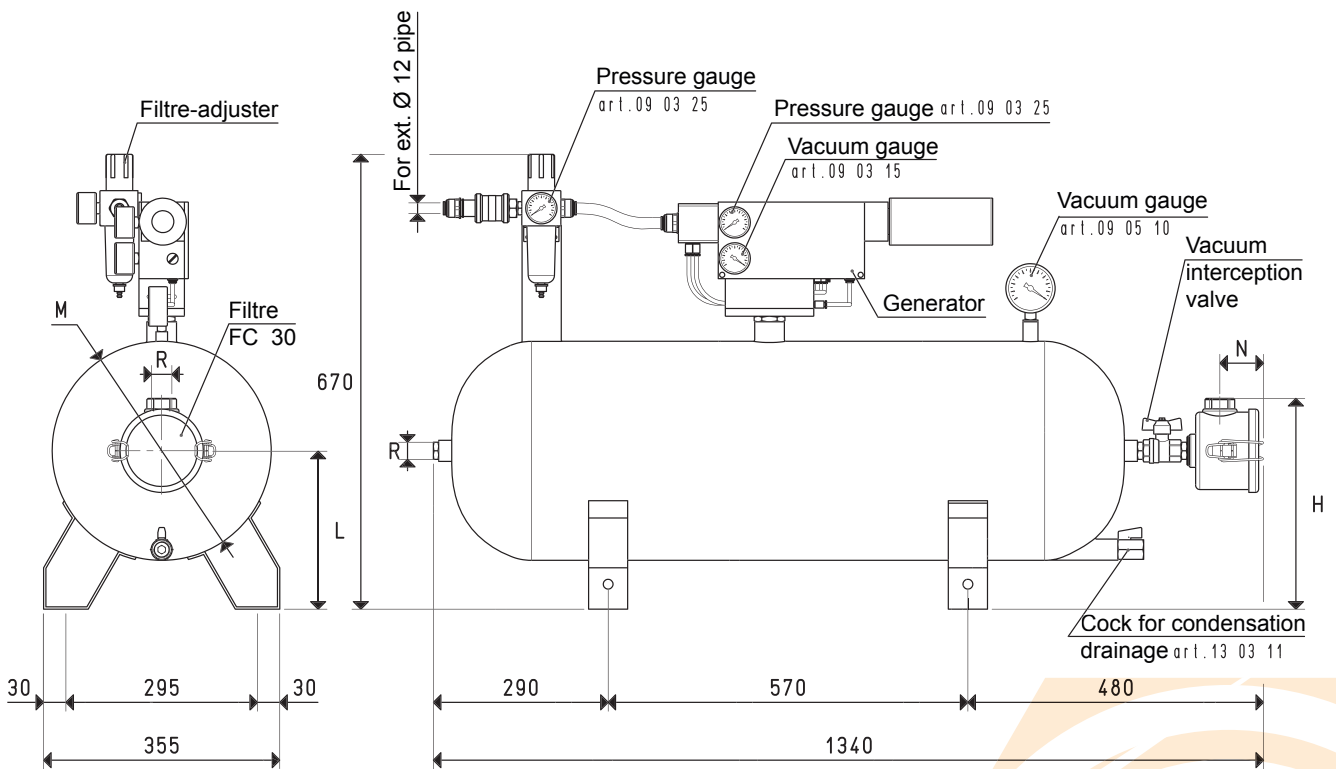

Art.	Tank	Generator	Pneumatic device	H	L	M	N	R	Weight
	Litres	art.	art.			Ø		Ø	Kg
DOP 100 PVP 75 MDX	100	PVP 75 MDX ES	DOP 50 90	300	255	350	41	G1"	31.0

Conversion ratio: inch = $\frac{mm}{25.4}$; pounds = $\frac{g}{453.6} = \frac{Kg}{0.4536}$

GAS-NPT thread adapters available at page 1.117

PNEUMATIC PUMPSETS DOP 150 and DOP 300

Pneumatic pumpsets are independent vacuum units fed exclusively by compressed air.

They are composed of:

- A welded sheet steel tank.
- A compressed air-operated vacuum generator.
- A pneumatic vacuum switch for adjusting the vacuum level.
- Un vacuum gauge for a direct reading of the vacuum level.
- A manual valve for vacuum interception.
- A suction filtre with an FC paper cartridge.
- A pressure adjuster equipped with filtre.
- A pneumatic activation valve for the vacuum generator supply.
- A sleeve valve for compressed air interception.
- A cock for draining condensation from the tank.

the vacuum level in the tank, previously set with the vacuum switch, is automatically maintained. Pneumatic pumpsets are normally used for handling particularly heavy or valuable loads, since even in case of a sudden power supply failure, allow the vacuum cups to maintain the grip for a certain amount of time (which varies according to the tank capacity). They are recommended for connecting several applications to centralise the vacuum. In any case, the use of the pumpset offers a great advantage under an energy-saving point of view, since the generator operates only when vacuum is required by the application.

Pneumatic pumpsets require no electricity, only compressed air at a 4 ÷ 6 bar (g) pressure. For this feature, they are recommended in hazardous environments where an ignition source would be dangerous.

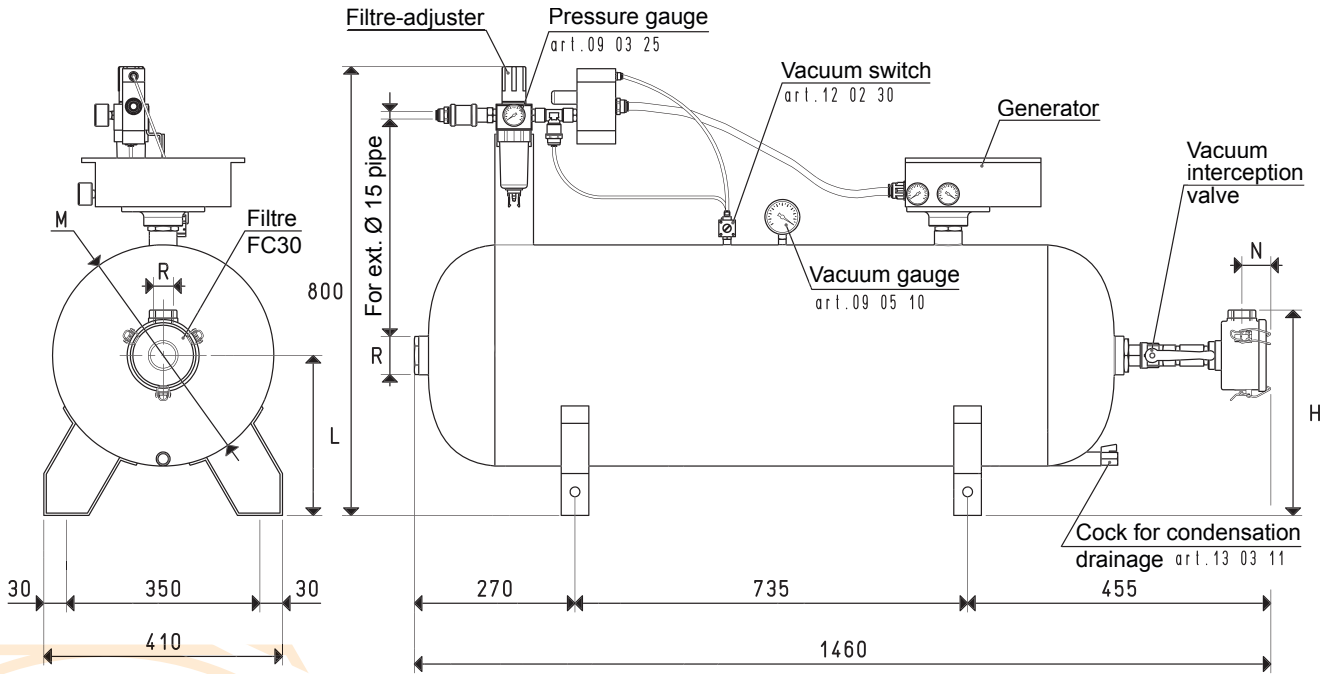

3D drawing available at www.vuototecnica.net

Art.	Tank	Generator	Pneumatic device	H	L	M	N	R	Weight
	Litres	art.	art.			Ø		Ø	Kg
DOP 150 PVP 150 MD	150	PVP 150 MDR	DOP 150 90	360	280	400	41	G1"	40.2

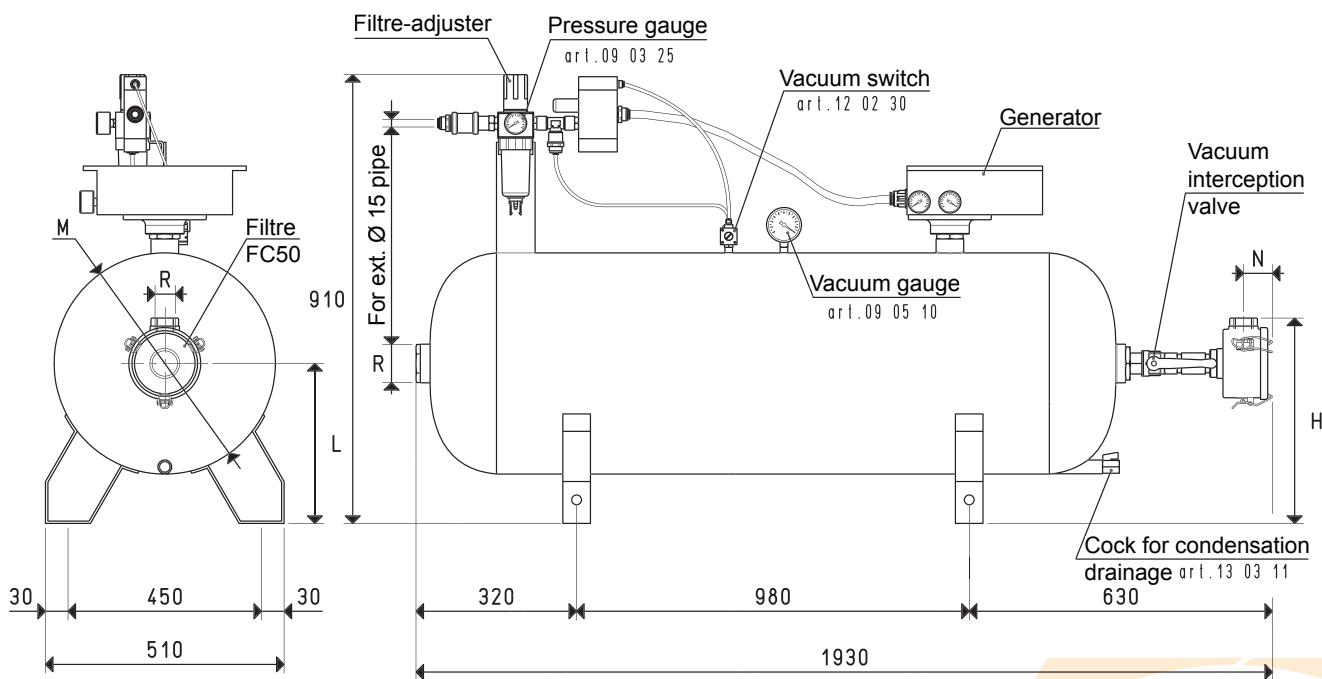

Art.	Tank	Generator	Pneumatic device	H	L	M	N	R	Weight
	Litres	art.	art.			Ø		Ø	Kg
DOP 300 PVP 300 MD	300	PVP 300 MDR	DOP 150 90	440	340	500	45	G1"1/2	41.2

Conversion ratio: inch = $\frac{mm}{25.4}$; pounds = $\frac{g}{453.6} = \frac{Kg}{0.4536}$

GAS-NPT thread adapters available at page 1.117

PNEUMATIC MINI PUMPSET AND PUMPSET COMPONENTS

Mini pneumatic pumpset tanks DOP 06 and 10

Mini pneumatic pumpset tanks are horizontal with a rectangular section. They are made with welded sheet steel, a perfect vacuum seal, and varnished with special paints resistant to water condensation corrosion.

They are set for the installation of a vacuum generator to be chosen in the table and a pneumatic device.

They are equipped with:

- A pneumatic vacuum switch for adjusting the maximum vacuum level.
- Un vacuum gauge for a direct reading of the vacuum level in the tank.
- A check valve suitable for the generator connection.
- A manual valve for vacuum interception.
- A suction filtre with an FC paper cartridge.
- A cock for condensation drainage.
- Hoses, fittings and screws for connecting and fixing the generator to the tank.

Available with volumes of 6 and 10 litres.

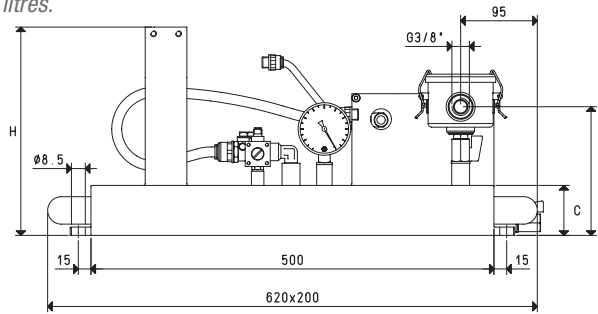
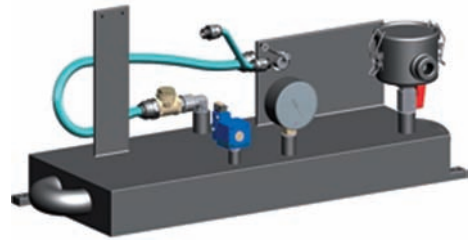

Art.	Tank Litres	Weight Kg	C	E	H	Set for:	
						Generator art.	Pneumatic device art.
DOP 06 01	6	11.4	60	150	250	PVP 12 MX	DOP 06 90
						PVP 25 MX	
DOP 10 01	10	11.6	100	210	290	PVP 12 MX	DOP 06 90
						PVP 25 MX	

Mini pneumatic pumpset tanks DOP 20

Mini pneumatic pumpset tanks are horizontal with a rectangular section.

They are made with welded sheet steel, a perfect vacuum seal, and varnished with special paints resistant to water condensation corrosion.

They are set for the installation of a pneumatic device and a PVP .. MDX ES generator to be chosen in the table which are provided with built-in servo-controlled supply slide valve, check valve and pneumatic vacuum switch.

They are equipped with:

- Un vacuum gauge for a direct reading of the vacuum level in the tank.
- A manual valve for vacuum interception.
- A suction filtre with an FC paper cartridge.
- A cock for condensation drainage.
- Hoses, fittings and screws for connecting and fixing the generator to the tank.

Available with a volume of 20 litres.

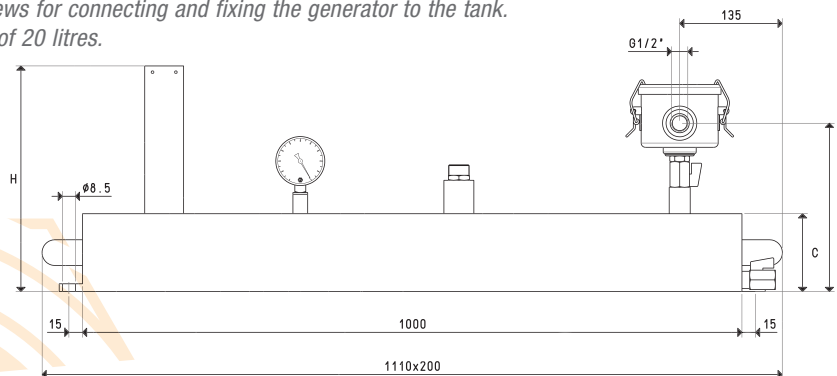
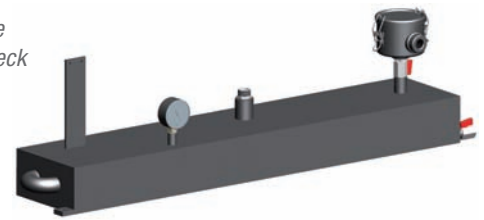

Art.	Tank Litres	Weight Kg	C	E	H	Set for:	
						Generator art.	Pneumatic device art.
DOP 20 01	20	18.2	100	225	290	PVP 25 MDX ES	DOP 20 90
						PVP 35 MDX ES	

3D drawing available at www.vuototecnica.net

PNEUMATIC PUMPSET TANKS DOP 25, 50 and 100



Pneumatic pumpset tanks are horizontal with a circular section. Made with welded sheet steel, a perfect vacuum seal, they are varnished with special paints resistant to water condensation corrosion.

They are set for the installation of a pneumatic device and a PVP .. MDX ES generator to be chosen in the table which are provided with built-in servo-controlled supply slide valve, check valve and pneumatic vacuum switch.

They are equipped with:

- A vacuum gauge for a direct reading of the vacuum level in the tank.
 - A manual valve for vacuum interception.
 - A cock for condensation drainage.
- Hoses, fittings and screws for connecting and fixing the generator to the tank.
Available with volumes of 25, 50 and 100 litres.*

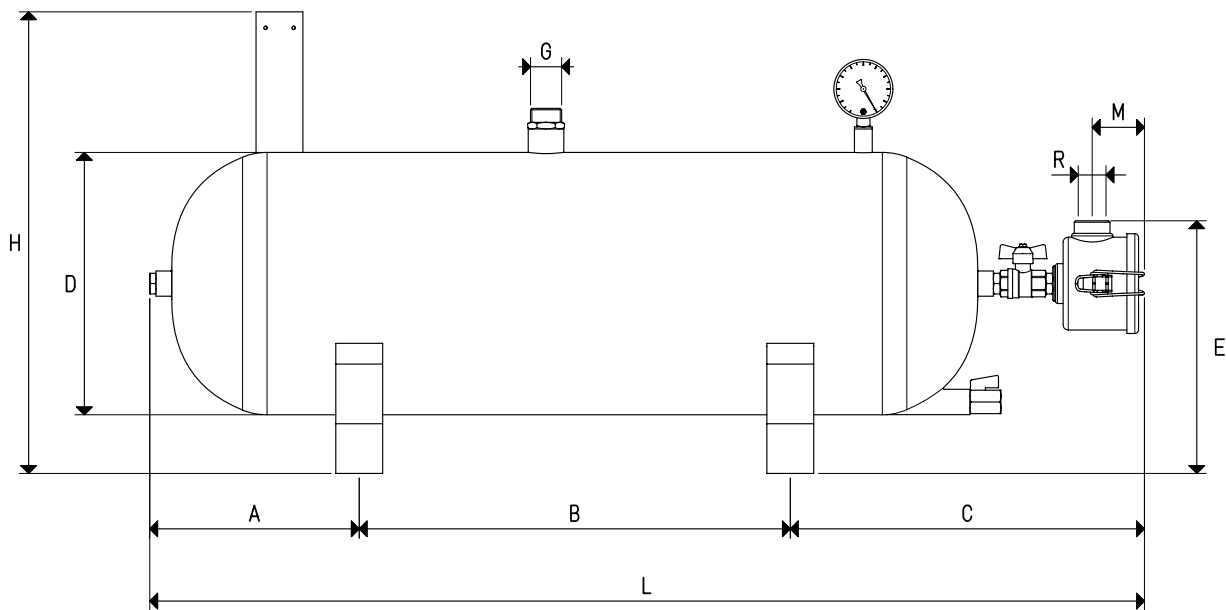

Art.	Tank Litres	Weight Kg	A	B	C	D ø	E	G ø	H	L	M	R ø	Set for:	
													Generator art.	Pneumatic device art.
DOP 25 01	25	13.5	200	250x210	330	240	225	G3/4"	485	780x270	51	G1/2"	PVP 25 MDX ES PVP 35 MDX ES	DOP 20 90
DOP 50 01	50	16.4	220	460x245	400	280	245	G3/4"	492	1080x300	51	G1/2"	PVP 50 MDX ES	DOP 20 90
DOP 50 02	50	16.4	220	460x245	400	280	245	G1"	492	1080x300	51	G1/2"	PVP 60 MDX ES	DOP 50 90
DOP 100 01	100	27.6	290	570x295	480	350	300	G1"	585	1340x355	41	G1"	PVP 75 MDX ES	DOP 50 90

TANKS FOR PNEUMATIC PUMPSETS DOP 150 e 300

Pneumatic pumpset tanks are horizontal with a circular section.

Made with welded sheet steel a perfect vacuum seal, they are varnished with special paints resistant to water condensation corrosion.

They are set for the installation of a pneumatic device and a PVP .. MDX ES generator to be chosen in the table which are provided with built-in servo-controlled supply slide valve, check valve and pneumatic vacuum switch.

They are equipped with:

- A pneumatic vacuum switch for adjusting the maximum vacuum level.
- Un vacuum gauge for a direct reading of the vacuum level in the tank.
- A manual valve for vacuum interception.
- A suction filtre with an FC paper cartridge.
- A cock for condensation drainage.
- Hoses, fittings and screws for connecting and fixing the generator to the tank.

Available with volumes of 150 and 300 litres.

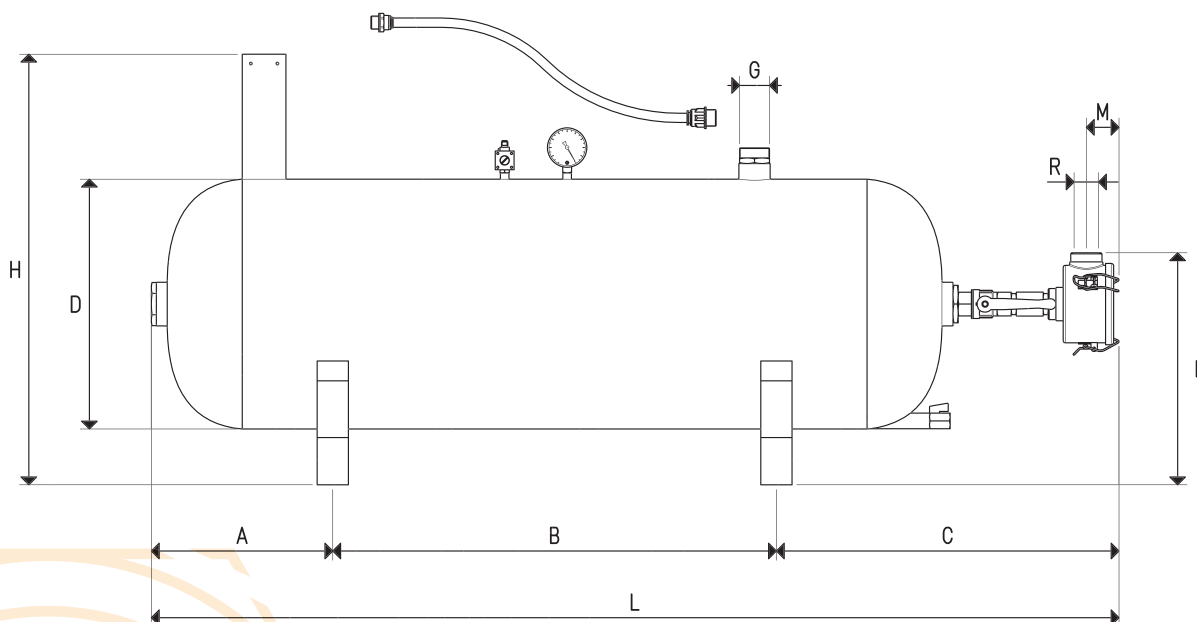
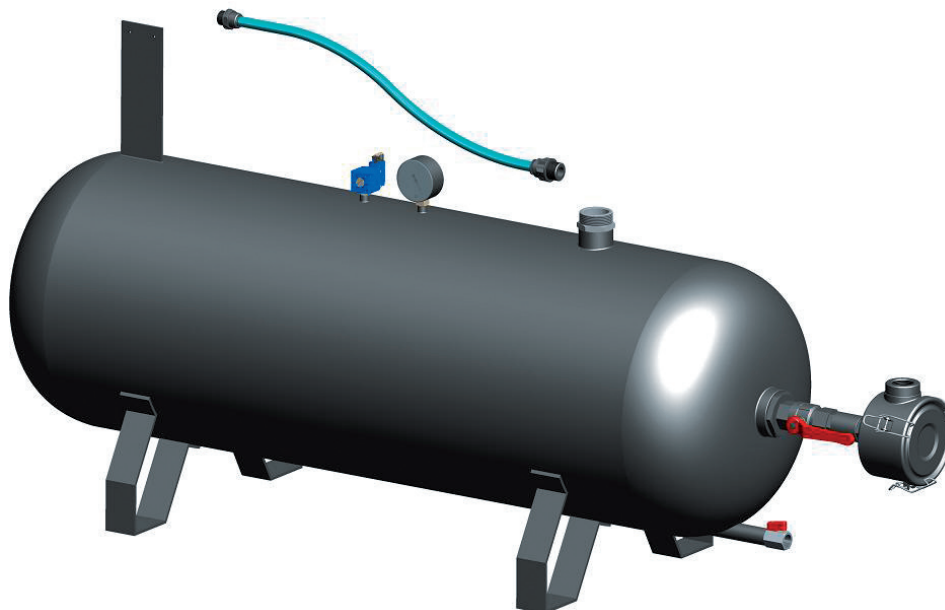

Art.													Set for:	
	Tank Litres	Weight Kg	A	B	C	D ø	E	G ø	H	L	M	R ø	Generator art.	Pneumatic device art.
DOP 150 01	150	31.3	270	735x350	455	400	360	G1"1/2	690	1460x410	41	G1"	PVP 150 MDR	DOP 150 90
DOP 300 01	300	50.2	320	980x450	630	500	440	G2"	775	1930x510	45	G1"1/2	PVP 300 MDR	DOP 150 90

PNEUMATIC CONTROL GEAR FOR MINI PUMPSETS DOP 06 and DOP 10

The mini pumpset pneumatic control gear manages a vacuum generator and automatically maintains the vacuum level, set with the pneumatic vacuum switch, in the tank.

It is composed of:

- A pressure filtre-adjuster provided with pressure gauge, for adjusting the compressed air supply.
- A slide valve for compressed air interception.
- A 3-way servo-controlled valve for the vacuum generator supply
- Fittings and hoses for connecting the various component and screws for fixing them to the support

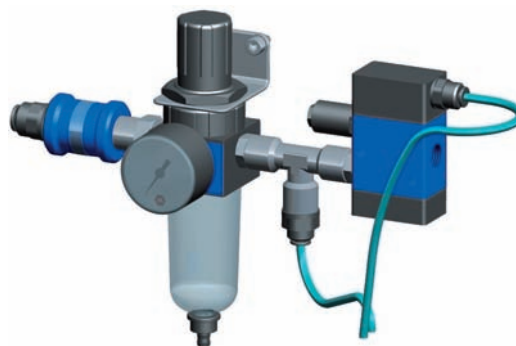
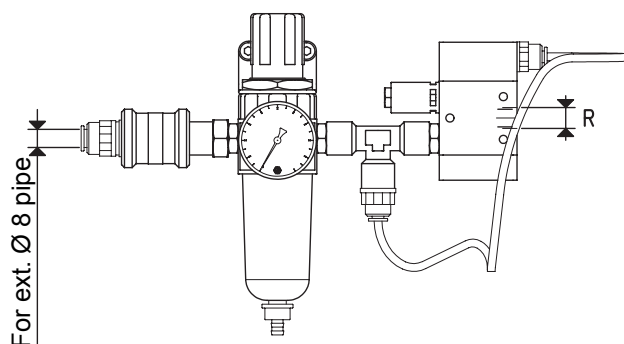

Art.	Weight Kg	R Ø	For Generator art.
DOP 06 90	0.6	G1/4"	PVP 12 MX PVP 25 MX PVP 25 MDX PVP 35 MDX PVP 50 MDX

PNEUMATIC CONTROL GEAR FOR MINI PUMPSETS DOP 20 AND PUMPSETS DOP 25, 50 and 100

The pneumatic control gear for these pumpsets manages a vacuum generator and automatically maintains the vacuum level, set with the built-in pneumatic vacuum switch, in the tank.

It is composed of:

- A pressure filtre-adjuster provided with pressure gauge, for adjusting the compressed air supply.
 - A slide valve for compressed air interception.
 - Fittings and hoses for connecting the various component and screws for fixing them to the support.
- Available in two sizes according to the supply connection.

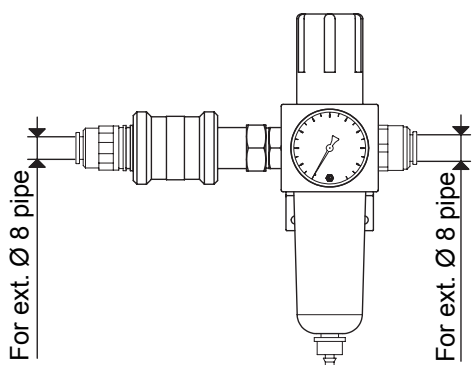

Art.	Weight Kg	For generator art.
DOP 20 90	0.4	PVP 25 MDX ES PVP 35 MDX ES PVP 50 MDX ES

PNEUMATIC CONTROL GEAR FOR PUMPSETS DOP 50 and 100

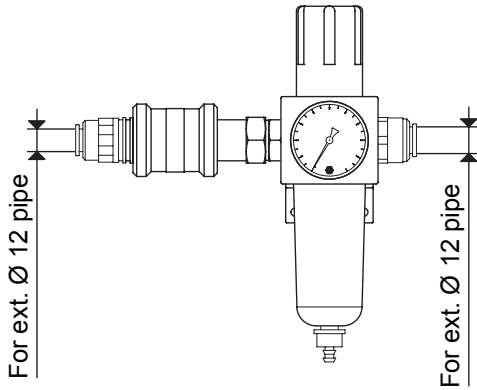

Art.	Weight Kg	For Generator art.
DOP 50 90	0.4	PVP 60 MDX ES PVP 75 MDX ES

PNEUMATIC CONTROL GEAR FOR PUMPSETS DOP 150 and 300

The pneumatic control gear for these pumpsets manages a vacuum generator and automatically maintains the vacuum level, set with the pneumatic vacuum switch, in the tank.

It is composed of:

- A pressure filtre-adjuster provided with pressure gauge, for adjusting the compressed air supply.
- A slide valve for compressed air interception.
- A 3-way servo-controlled valve for the vacuum generator supply
- Fittings and hoses for connecting the various component and screws for fixing them to the support.

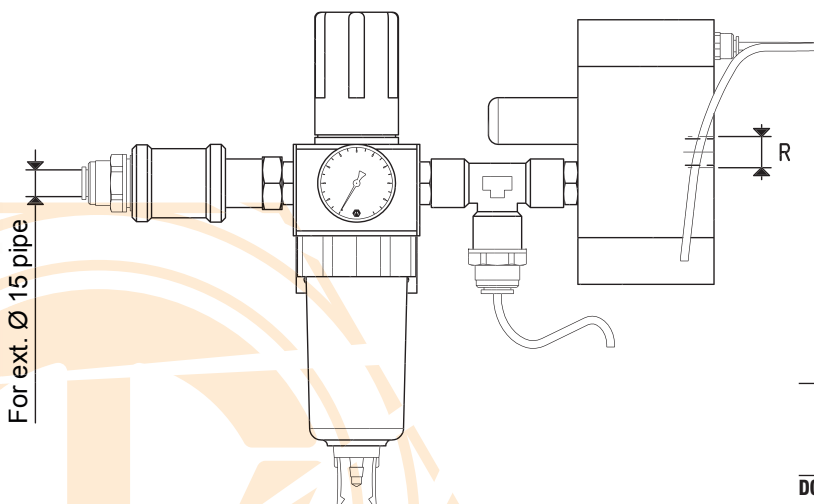
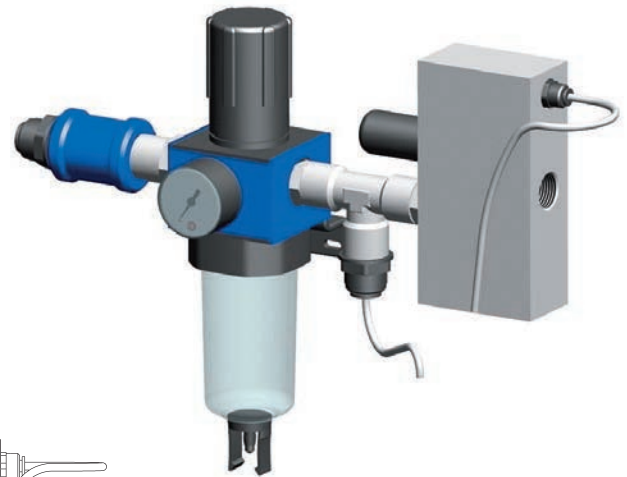

Art.	Weight Kg	R Ø	For Generator art.
DOP 150 90	1.1	G1/2"	PVP 150 MDR PVP 300 MDR